



Prosilica Launches New Range of Single-Board Gigabit Ethernet Cameras

page 1

Prosilica GigE Vision Cameras Tested for New NASA Recording System

page 3

Focus On: Prosilica's SDK

page 4

GigE Vision is "Rock Solid"

page 5

Prosilica Launches New Range of Single-board Gigabit Ethernet Cameras

The GB-Series are the very first board level cameras to feature a GigE Vision interface.

Measuring only 51 x 89 mm, these credit-card size cameras have been specially designed for OEM applications where there is a need to fit machine vision cameras within tight spaces. The GB-Series cameras feature progressive scan Sony CCD sensors for high image quality and excellent sensitivity, and are ideally suited for applications such as machine vision, industrial inspection, avionics, traffic monitoring, license plate reading, public security, intelligent transportation systems (ITS), character recognition, biometrics, robotics and surveillance.

The cameras have a C-mount lens mount with adjustable back focus or an optional CS-mount. The GigE Vision compliant

gigabit Ethernet interface allows cable lengths of up to 100m (300ft) long using conventional Ethernet cabling (Cat5e).

High Performance and Versatility

This new series of ultra-compact CCD cameras combines a rugged industrial

design with high performance and high reliability. Four models are currently available, GB650, GB660, GB1380 and GB2450, ranging from VGA to 5 megapixel resolution and frame rates to 120 fps at full resolution.

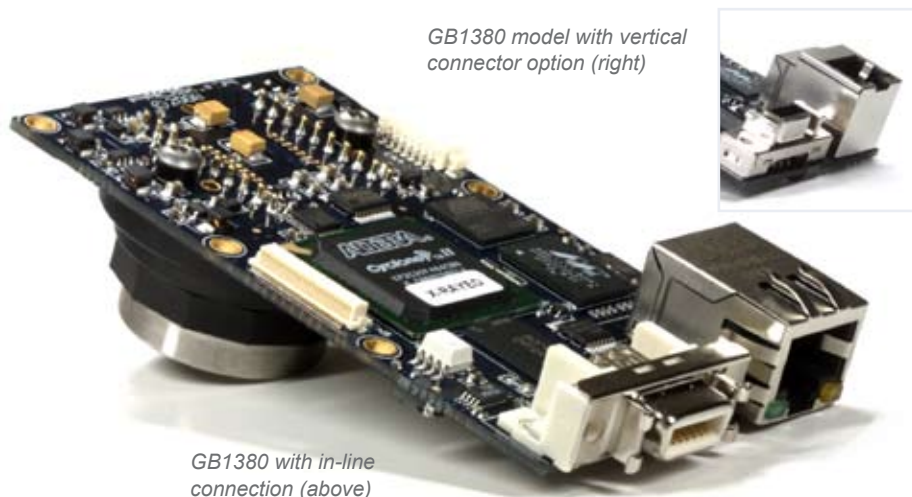

GB1380 model with vertical connector option (right)

GB1380 with in-line connection (above)



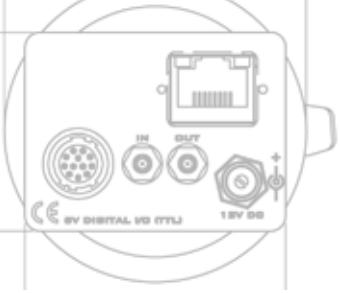

Designed for OEM applications the GB-Series cameras are extremely versatile and are available in color or monochrome models, with landscape or portrait orientation (GB650 and GB1380) and with in-line or vertical connector orientation for unprecedented ease of integration.

Advanced camera features

Like all Prosilica cameras the GB-Series incorporate an advanced set of camera features including snapshot/global shutter, pixel binning, area of interest

readout, external trigger and sync I/O, auto-iris control, RS-232 peripheral port, exposure, gain and offset controls, non-volatile configuration memory, event recorder capability, pre-trigger recording, programmable strobe functions, multicasting, configurable IP addresses, autoexposure and autowhite balance controls.

» For further information on the GB-Series please visit our web site at www.prosilica.com

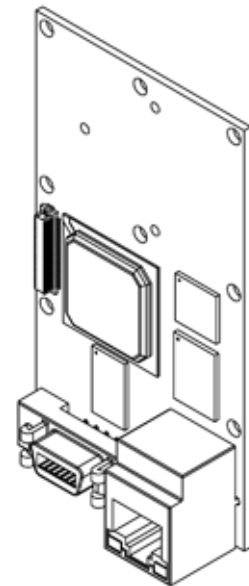
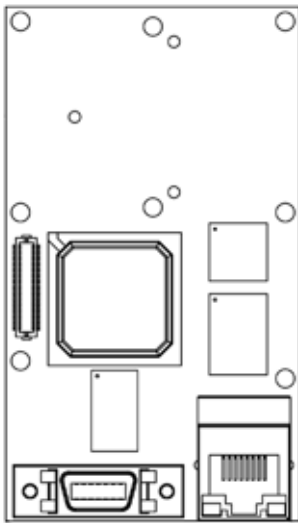

Technical drawing of the GB660 (with vertical connection option)

Prosilica GigE Vision Cameras Tested for New NASA Recording System

Prosilica's GigE Vision Cameras GC650, GC660 and GC1380H are being tested by NASA as the Agency is looking to upgrade one of its existing space shuttle video/camera recording systems.

System Set-up

Developed by image acquisition and processing specialists Alacron, the new system, currently in development, will record the vehicle's health and status during liftoff and free fall-back to Earth and must be able to endure vibration

and shock at high G forces as well as record multiple hundreds of megabytes per second over an extended period. In addition, the system must store and retain data despite power loss, provide camera control and have the ability to download data afterwards via common data interfaces (including GigE) to computer systems running any operating system without the installation of special software. The system, named Fast-Vault, is a combination of two on-board systems into a 6U VME-form-factor board; a high-speed, 320-Gbyte flash memory system; and an I/O subsystem that provides interfaces to multiple cameras, along with analog and digital inputs.

ruggedness and high level of performance in the most demanding applications.

The GC650, GC660 and GC1380H are noted for ultra-compact size which facilitates integration in systems where space is limited, fast frame rates (up to 120 fps at full resolution and even faster using area of interest readout) and excellent image quality.

In addition, Prosilica's GigE cameras are capable of streaming data at a sustained rate of 125 megabytes per second over their gigabit Ethernet interface - 25% faster than our nearest competitor.

» [Click here to read the full article](#)

» www.alacron.com

» www.nasa.gov

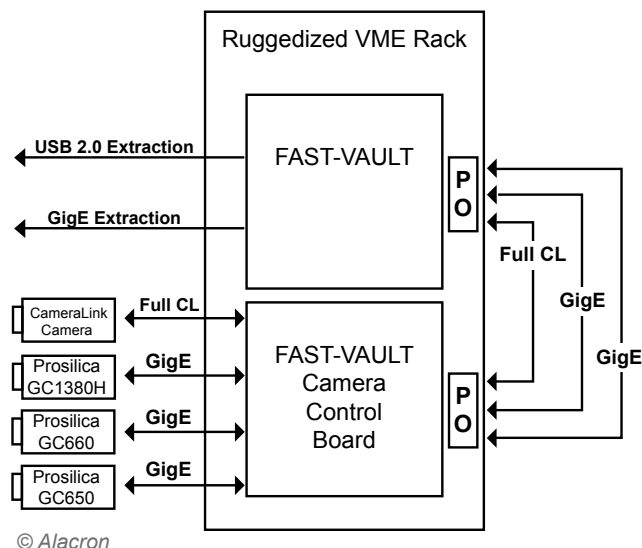

© Alacron

Initial Prototype Configuration

Prosilica's Software Development Kit for GigE Vision

Developed entirely in-house, the Prosilica SDK for GigE Vision is provided free of charge alongside the GigE Viewer software for fast and simplified integration. The SDK allows users to programmatically control and capture images from Prosilica's wide range of GigE Vision cameras (GE-Series, GC-Series and the new single-board range of GB-Series).

Windows, Linux and QNX platforms

Originally released for Windows users (2000, XP and Vista), Prosilica also offers SDKs which support Linux and QNX operating systems on both Intel and Power PC platforms, enabling users to run our GigE Vision cameras on low-cost SBC computers for embedded and OEM applications. Prosilica has also released a MAC OS X SDK.

Advanced Functions

The Software Development Kit allows programmers to set and control all functions of the image capturing process including image mode, image format, acquisition control, feature control (exposure, white balance, auto-iris, etc.), IO control and much more.

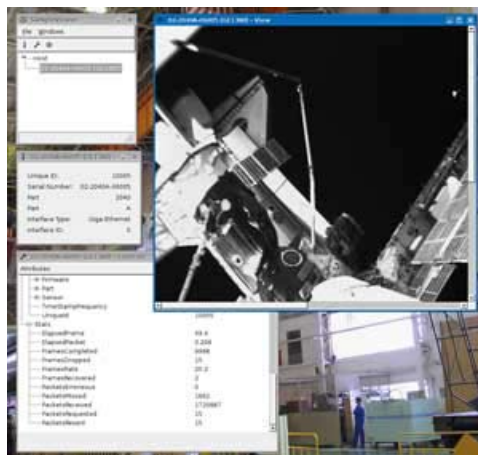

Programming compatibility

The Software Development Kit includes sample code to allow programmers to quickly integrate Prosilica's cameras into their own applications using C++ and other programming languages and platforms including .NET and Visual Basic 6 for Windows, Linux and QNX. Java for Windows and Linux will be available in the next release of the SDK.



Gigabit Ethernet

Firewire (1394)

Ultra-Compact

PROSILICA

High-Performance
CCD and CMOS Cameras

www.prosilica.com

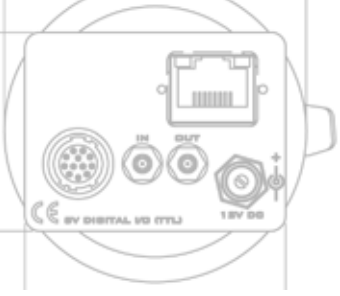

GigE Vision is “Rock Solid”

Prosilica attended The Vision Show, North America’s leading showcase of machine vision and imaging components and solutions, which took place in Boston from June 10th-12th.

GigE Vision is Choice Interface

Prosilica took this opportunity to unveil the GB-Series, its latest range of single-board digital cameras with Gigabit Ethernet interface technology (see page 1 for further information).

The show further demonstrated that GigE Vision is the interface of choice for new applications. It is clear that support for

GigE Vision from third party solutions providers shows that the interface has become the interface of choice for machine vision cameras.

AIA testing

Prosilica took part in the Plugfest event organised by the AIA (Automated Imaging Association), which invites industry leaders to test interoperability between GigE Vision compliant devices. All of Prosilica’s Gigabit Ethernet cameras (GE-Series, GC-Series and GB-Series) proved fully compliant with third-party drivers from National Instruments, Matrox, Common Vision Blox, Halcon and Cognex

proving again that GigE Vision is the interface of choice for the machine vision industry.

Next: Vision Show 2008, Stuttgart

Prosilica will be on the road again at the Vision Show 2008 in Stuttgart, Germany on November 4th-6th.

Prosilica Adds New Sales Channel in Florida

Prosilica is pleased to announce the appointment of Pyramid Imaging as their new US South East dealer.

Based in Tampa, Florida, Pyramid Imaging specializes in selling video imaging products, including Prosilica’s GigE Vision cameras, to the region’s machine vision, medical, research, academic and military markets.

“We are glad to welcome Pyramid Imaging on board as this further establishes Prosilica’s position as the leading provider of machine vision cameras in the South East” says Marty Furse, CEO, Prosilica.

» www.pyramidimaging.com

Published by:

Prosilica Inc.

101 - 3750 North Fraser Way
Burnaby, BC
V5J 5E9
Canada
Tel: +1 604.875.8855
Fax: +1 604.875.8856

sales@prosilica.com
support@prosilica.com

www.prosilica.com