

ALVIUM MIPI CSI-2 CAMERAS

Adapter Boards for Nitrogen6_MAX and Wandboard i.MX6

User Guide

V1.1.0

**Quick links**

- [MIPI CSI-2 adapter boards at a glance](#) on page 15
- [Contact us](#) on page 17
- [Contents](#) on page 18

Read before use

EN - English

Safety

Before using the product, read these safety instructions. Observe the warnings at all times. Use the product only as stated in the [Intended use](#) on page 24.

**CAUTION****Risk of burns**

The product in operation can reach temperature levels which could cause burns.

**CAUTION****Risk of cuts by sharp edges**

The product can have sharp edges.

Intended use

Intended use of Allied Vision product is the integration into vision systems by professionals. All Allied Vision product is sold in a B2B setting.

DA - Dansk

Sikkerhed

Læs sikkerhedsanvisningerne, før produkt bruges. Overhold alle advarsler. Brug kun produkt som anført i [Intended use](#) på side 24.



FORSIGTIG

Forbrændingsfare

Når produkt bruges, kan det blive meget varmt og forårsage forbrændinger.



FORSIGTIG

Fare for skarpe kanter

Produktet kan have skarpe kanter.

Tilsigtet brug

Allied Vision produktets tilsigtede brug er en indbygning i et visionssystem, udført af fagfolk. Alle Allied Vision produkter sælges i B2B.

DE - Deutsch

Sicherheit

Bevor Sie das Produkt benutzen, lesen Sie diese Sicherheitshinweise. Beachten Sie diese Hinweise immer. Verwenden Sie das Produkt nur wie beschrieben in [Intended use](#) auf Seite 24.



VORSICHT

Gefahr von Verbrennungen

Im Betrieb kann das Produkt Temperaturen erreichen, die zu Verbrennungen führen.



VORSICHT

Schnitte durch scharfe Kanten

Das Produkt kann scharfe Kanten haben.

Bestimmungsgemäßer Gebrauch

Allied Vision Produkte sind bestimmt für die Integration in Bildverarbeitungssysteme durch Fachpersonal. Alle Allied Vision Produkte werden in einer B2B-Umgebung verkauft.

ES - Español

Seguridad

Antes de utilizar el producto lea estas instrucciones de seguridad. Observe las advertencias en todo momento. Utilice el producto solo tal y como se estipula en el [Intended use](#) en la página 24.



ATENCIÓN

Riesgo de quemaduras

El producto en funcionamiento puede alcanzar temperaturas que podrían provocar quemaduras.



ATENCIÓN

Riesgo de cortes por bordes afilados

El producto puede tener bordes afilados.

Uso previsto

El uso previsto del producto Allied Vision es la integración en el sistema de visión por parte de profesionales. Todos los productos Allied Vision se venden dentro de una relación B2B.

FI - Suomi

Turvallisuus

Lue nämä turvallisuusohjeet ennen tuotteen käyttöä. Noudata tuotetta joka hetki. Käytä tuotteen ainoastaan kohdassa [Intended use](#) sivulla 24 kuvatulla tavalla.



HUOMIO

Palovammojen vaara

Käytössä olevan tuotteen saavuttamat lämpötilatasot voivat aiheuttaa palovammoja.



HUOMIO

Terävien reunojen aiheuttama viiltovaara

Tuotteessa voi olla teräviä reunoja.

Käyttötarkoitus

Allied Vision-tuotteen käyttötarkoitus on integrointi kuvajärjestelmiin ammattilaisten toimesta. Kaikki Allied Vision-tuotteet myydään B2B-ympäristössä.

FR - Français

Sécurité

Veuillez lire ces consignes de sécurité avant d'utiliser le produit. Respectez continuellement les avertissements. Utilisez le produit uniquement comme indiqué sous [Intended use](#), page 24.



ATTENTION

Risque de brûlures

Le produit en service peut atteindre des niveaux de température susceptibles d'entraîner des brûlures.



ATTENTION

Risque de coupures sur des bords tranchants

Le produit peut présenter des bords tranchants.

Utilisation prévue

L'utilisation prévue du produit Allied Vision est son intégration dans des systèmes de vision par le soin de professionnels. Tout produit Allied Vision est vendu dans un cadre B2B.

עברית - HE

בטיחות

לפני השימוש במוצר, עליך לקרוא את הוראות הביטחון האלו. עליך לממש הוראות ביטחון אלו תמיד. השימוש במצלמה הוא רק לפי מה שכתוב ב"כוונת השימוש" (Intended use בעמוד 24).

זהירות

סכנת כווייה

בזמן הפעלת המוצר עלולות לעלות טמפרטורות גבוהות, שיכולות לגרום לכוויות.



זהירות

סכנת חתכים על ידי קצוות חדים

למוצר יכולים להיות קצוות חדים.



שימוש מיועד

מוצרי AlliedVision מיועדים לשילוב במערכות ממוחשבת לעיבוד צילומים ע"י אנשי מקצוע. כל מוצרי AlliedVision נמכרים לשימוש בסביבת B2B.

IT - Italiano

Sicurezza

Leggere queste istruzioni per la sicurezza prima di utilizzare il prodotto. Osservare sempre tutte le avvertenze. Utilizzare il prodotto come descritto alla sezione [Intended use](#) a pagina 24.



ATTENZIONE

Pericolo di ustioni

Durante il funzionamento, il prodotto può raggiungere temperature elevate che possono essere causa di ustioni.



ATTENZIONE

Pericolo di tagliarsi sui bordi affilati

I bordi del prodotto lente possono essere affilati.

Uso previsto

Il prodotto Allied Vision è concepito per essere integrato in sistemi di monitoraggio in campo professionale. Tutti i prodotti Allied Vision sono venduti in uno scenario B2B.

JA – 日本語

安全性

本製品を使用する前に、この安全ガイドをお読みください。警告を必ず守ってください。必ず21ページのIntended use 24 ページに従って使用してください。



注意

やけどの危険性

作動中のカメラは、やけどを引き起こす温度まで熱くなる恐れがあります。



注意

な端部で切り傷の危険性

本製品には鋭利な部分がある場合があります。

用途

Allied Vision製品は、専門家が視覚装置に統合することを意図したものです。すべてのAllied Vision製品は、企業間取り引き用に販売されています。

NL - Nederlands

Veiligheid

Lees deze veiligheidsinstructies voordat u het product gebruikt. Neem deze waarschuwingen altijd in acht. Gebruik het product uitsluitend, zoals aangegeven in het [Intended use](#) op pagina 24.



VOORZICHTIG

Risico van verbranding

Het gebruikte product, kan temperatuurwaarden bereiken die brandwonden kunnen veroorzaken.



VOORZICHTIG

Risico van snijwonden door scherpe randen

Het product kan scherpe randen hebben.

Beoogd gebruik

Het beoogde gebruik van het Allied Vision-product is de integratie in optische systemen door professionals. Alle Allied Vision-producten worden verkocht in de B2B-markt.

NO - Norsk

Sikkerhet

Les disse sikkerhetsinstruksene før du bruker produkt. Følg advarslene til en hver tid. Bruk kun produkt i samsvar med [Intended use](#) på side 24.



FORSIKTIG

Risiko for brannskader

Produktet i bruk kan nå temperaturnivåer som kan forårsake brannskader.



FORSIKTIG

Risiko for kutt fra skarpe kanter

Produktet kan ha skarpe kanter.

Tiltenkt bruk

Den tiltenkte bruken av Allied Vision-produktet er integrering i visjonssystemer av profesjonelle. Alle Allied Vision-produkter selges i en forretning til forretning-situasjon.

SV - Svenska

Säkerhet

Läs igenom säkerhetsinstruktionerna innan du använder produkten. Var hela tiden särskilt uppmärksam på varningarna. Använd enbart produkten på det sätt som anges i [Intended use](#) på sida 24.



VARNING

Risk för brännskada

Produkten i drift kan komma upp i temperaturer som kan orsaka brännskador.



VARNING

Risk för skärsår från vassa kanter

Produkten kan ha vassa kanter.

Avsedd användning

Den avsedda användningen av Allied Vision-produkter är integrering i visionsystem av fackmän. Samtliga Allied Vision-produkter säljs i en B2B-miljö.

ZH – 简体中文版

安全需知

在使用产品之前，请阅读这些安全说明。请务必遵守相关警告 和 [Intended use](#) 于第 24 页。



注意事项

烫伤风险

在产品运行过程中，温度可能会上升，导致烧伤的危险。



注意事项

锋利边缘割伤的风险

产品可能有锋利的边缘。

预期用途

Allied Vision 产品的预期用途是由专业人士整合到视觉系统中。所有 Allied Vision 的产品均通过 B2B 渠道销售。

MIPI CSI-2 adapter boards at a glance



Read this document carefully

Learn to use adapter boards in the most safe and efficient way and avoid damage to your embedded system.

Shipping contents



Components not included

FPC cables and microSD cards are not included in the shipping contents.

Adapter Board for Boundary Devices Nitrogen6_MAX

| No. | Component | Details |
|-----|---------------|--|
| 1 | Adapter board | For Boundary Devices Nitrogen6_MAX |
| 2 | I/O terminal | Phoenix MC 1,5/6-G-3,5 Removable |
| 3 | Cable tie | 75 mm × 2.5 mm |
| 4 | Nut | M2 |
| 5 | Bolt | M2 × 10 mm |
| 6 | Washers | 2 pieces M2 Inside diameter: 2.2 mm Outside diameter: 4.5 mm Thickness: 0.3 mm to 0.5 mm |
| 7 | Jumper | Standard, plastic isolation |

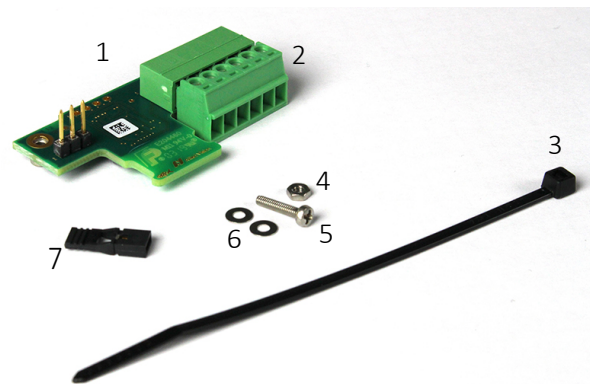

Table 1: Shipping contents for adapter for Nitrogen6_MAX

Adapter Board for Wandboard i.MX6 Series

| No. | Component | Details |
|-----|----------------|---|
| 1 | Adapter board | For Wandboard i.MX6 series |
| 2 | Spacer sleeves | 2 pieces Only for Wandboard i.MX6 Solo and Dual M3 Inside diameter: 3.5 mm Outside diameter: 6 mm Thickness: 4 mm |
| 3 | I/O terminal | Phoenix MC 1,5/4-G-3.5 Removable |
| 4 | Spacer bolts | 2 pieces 10 mm × 5 mm Inside thread: M3 × 6.5 mm Outside thread: M3 × 8 mm |
| 5 | Jumper | Standard, plastic isolation |

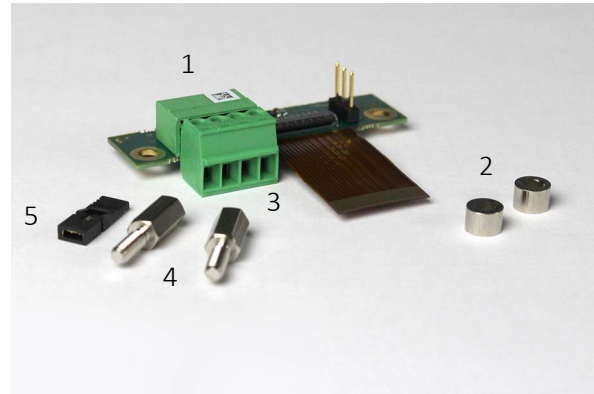

Table 2: Shipping contents for adapter for Wandboard i.MX6

What else do you need?



Technical information and ordering

For all information about Alvium CSI-2 cameras and accessories, see

- for MIPI CSI-2 cameras: www.alliedvision.com/en/support/technical-documentation/alvium-csi-2-documentation.
- Please contact your Allied Vision Sales representative for ordering and for additional information on hardware options for Alvium cameras.

Contact us

Website

General

www.alliedvision.com/en/contact

Distribution partners

www.alliedvision.com/en/about-us/where-we-are

Email

General

info@alliedvision.com

Support

support@alliedvision.com

Sales Offices

Europe, Middle East, and Africa

T// +49 36428 677-230

North and South America

Toll-free: +1 877 USA 1394

T// +1 978 225 2030

California: +1 408 721 1965

Asia-Pacific

T// +65 6634 9027

China

T// +86 21 64861133

Headquarters

Allied Vision Technologies GmbH

Taschenweg 2a

07646 Stadtroda, Germany

T// +49 36428 677-0

F// +49 36428 677-28

Contents

| | |
|--|----|
| Read before use | 2 |
| MIPI CSI-2 adapter boards at a glance | 15 |
| Shipping contents | 15 |
| Adapter Board for Boundary Devices Nitrogen6_MAX | 15 |
| Adapter Board for Wandboard i.MX6 Series | 16 |
| What else do you need? | 16 |
| Contact us | 17 |
| Document history and conventions | 20 |
| Document history | 21 |
| Conventions used in this user guide | 21 |
| Typographical styles | 21 |
| Symbols and notes | 21 |
| Component naming | 22 |
| Compliance, safety, and intended use | 23 |
| Compliance notifications | 24 |
| Intended use | 24 |
| Your safety | 24 |
| Handling hot adapter boards | 24 |
| Sharp edges | 24 |
| Product safety | 25 |
| Embedded systems | 25 |
| Electrical connections | 25 |
| Electrostatic discharge (ESD) | 25 |
| Camera power | 25 |
| FPC connectors | 26 |
| Copyright and trademarks | 27 |
| Specifications | 28 |
| Specifications: Adapter for Nitrogen6_MAX | 29 |
| Dimensions and PCB layout | 30 |
| Electronic schematics | 31 |
| I/O screw terminal | 32 |
| Specifications: Adapter for Wandboard i.MX6 | 33 |
| Dimensions and PCB layout | 34 |
| Electronic schematics | 35 |
| I/O screw terminal | 36 |

| | |
|---|----|
| Using adapter boards | 37 |
| Embedded system accessories | 38 |
| Connecting FPC cables to Hirose FPC connectors | 38 |
| Installing the adapter for Nitrogen6_MAX | 40 |
| Connecting the camera FPC cable | 40 |
| Fastening the FPC cable with a cable tie | 41 |
| Connecting the embedded board | 42 |
| Tightening the mounting bolt | 44 |
| Removing and inserting microSD cards | 44 |
| Setting power modes | 45 |
| Connecting the camera | 45 |
| Installing adapter boards for Wandboard i.MX6 Solo and Dual | 46 |
| Connecting the embedded board | 46 |
| Mounting the adapter board | 47 |
| Removing and inserting microSD cards | 48 |
| Installing adapter boards for Wandboard i.MX6 Quad and QuadPlus | 49 |
| Removing the embedded board's heat sink | 49 |
| Connecting the embedded board | 50 |
| Mounting the adapter board | 51 |
| Removing and inserting microSD cards | 52 |
| Setting power modes for Wandboard i.MX6 series | 53 |
| Connecting Wandboard i.MX6 series boards to the camera | 54 |

Document history and conventions



This chapter includes:

| | |
|--|----|
| Document history | 21 |
| Conventions used in this user guide..... | 21 |
| Component naming | 22 |

Document history

| Version | Date | Remarks |
|---------|-------------|--|
| V1.1.0 | 2024-Mar-14 | Added Read before use on page 2. Added UKCA symbol in Compliance notifications on page 24. Added Your safety on page 24. Applied editorial changes. |
| V1.0.4 | 2020-Sep-02 | Applied editorial changes. |
| V1.0.3 | 2020-May-06 | Applied editorial changes. |
| V1.0.2 | 2019-Nov-27 | Removed note for additional information. |
| V1.0.1 | 2019-Nov-21 | <ul style="list-style-type: none"> Renamed the document to separate from other adapter boards' user guides. Applied editorial changes. |
| V1.0.0 | 2019-May-29 | Release version |

Table 3: Document history

Conventions used in this user guide

To give this user guide an easily understood layout and to emphasize important information, the following typographical styles and symbols are used:

Typographical styles

| Style | Function |
|--|---|
| Emphasis | Highlighting important things |
| Web links and references | Links to webpages and internal cross references |

Table 4: Typographical styles

Symbols and notes



NOTICE

Material damage

Precautions are described.

Practical tip

Additional information helps to understand or ease handling the camera and components

Additional information

Web link or reference to an external source with more information is shown.

Component naming

Components described in this user guide are not defined by common standards. Therefore, naming must be accurate to avoid misconceptions. Because naming is lengthy, reading is difficult. Simplified terms are used in this document.

| Long version | Short version | Alvium CSI-2 Cameras Safety and Usage Instructions |
|---|-----------------------------|--|
| Adapter Board for Boundary Devices Nitrogen6_MAX Series | adapter for Nitrogen6_MAX | Not applicable |
| Adapter Board for Wandboard i.MX6 Series | adapter for Wandboard i.MX6 | Not applicable |
| MIPI CSI-2 ¹ adapter board | adapter board | embedded board adapter |
| MIPI CSI-2 FPC cable | FPC cable | FPC cable |

¹MIPI CSI-2 Mobile Industry Processor Interface Camera Serial Interface 2

Table 5: MIPI CSI-2 adapter board naming

Compliance, safety, and intended use



This chapter includes:

| | |
|--------------------------------|----|
| Compliance notifications | 24 |
| Intended use | 24 |
| Your safety | 24 |
| Product safety | 25 |
| Copyright and trademarks | 27 |

Compliance notifications



National regulations on disposal must be followed.

Intended use

Allied Vision's objective is the development, design, production, maintenance, servicing and distribution of digital cameras and components for image processing. We are offering standard products as well as customized solutions.

Intended use of Allied Vision product is the integration into Vision systems by professionals. All Allied Vision product is sold in a B2B setting.

Allied Vision isn't a legal manufacturer of medical product. Instead, Allied Vision cameras and accessories may be used as components for medical product after design-in by the medical device manufacturer and based on a quality assurance agreement (QAA) between Allied Vision (supplier) and medical device manufacturer (customer). Allied Vision's duties in that respect are defined by ISO 13485, clause 7.2 (customer-related processes, equivalent to ISO 9001, clause 8.2).

Your safety

This section informs about issues related to your personal safety. Descriptions explain how to avoid hazards and use adapter boards safely.

Handling hot adapter boards

Electrical components of adapter boards get hot during operation.

Before operation, include adapter boards in housings that disable any contact to hot components.

Sharp edges

The edges of PCBs (printed circuit boards) and the assembled components can be sharp. Be careful these edges do not cut your skin when handling adapter boards.

Product safety

To prevent material damage, read the following to understand risks in using adapter boards.

Embedded systems

Setup and operation of Alvium CSI-2 cameras in embedded systems is different than for cameras in PC-based systems. Components can easily be damaged. If you are unfamiliar with embedded systems, be extremely careful. Follow the instructions in the Alvium CSI-2 Cameras User Guide.

Electrical connections

The MIPI CSI-2 standard does not specify electrical connections as extensively as USB or GigE standard. Read specifications carefully.

Alvium CSI-2 cameras are not protected against damage caused by reverse polarity.

Electrostatic discharge (ESD)

Electrostatic discharge (ESD) is dangerous for electronic devices, especially when tools or hands get in contact with connectors. We recommend measures to avoid damage by ESD:

- **Unpacking:** Remove the adapter board from its anti-static packaging only when your body is grounded.
- **Workplace:** Use a static-safe workplace with static-dissipative mat and air ionization.
- **Wrist strap:** Wear a static-dissipative wrist strap to ground your body.
- **Clothing:** Wear ESD-protective clothing. Keep components away from your body and clothing. Even if you are wearing a wrist strap, your body is grounded but your clothes are not.
- **Housing:** use an ESD protective housing, including the camera, embedded board, adapter board, and FPC cable.

Camera power

Operating cameras beyond the specified range damages cameras. Cameras are powered using the FPC connector at a maximum input of 5.5 VDC, using a limited power source (LPS), according to IEC62368-1: 2014 (Second Edition) with maximum 1.5 A per camera. Cameras are not intended to be connected to DC distribution networks.

FPC connectors

Hirose FH55-22S-0.5SH FPC connectors enable compact camera design. The small-sized connectors are sensitive to mechanical stress and are specified for maximum 20 mating and unmating cycles. Especially if you are inexperienced with this connector, be very cautious. If the FPC connector is broken, the complete device must be replaced. Follow the instructions in [Using adapter boards](#) on page 37 carefully.

- Avoid stress to FPC connectors.
- Allow only the FPC cable to touch conductors.

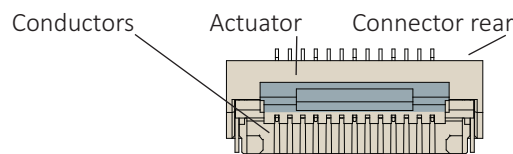

Figure 1: Hirose FH55-22S-0.5SH FPC connector



Additional information

For technical data and more instructions on the Hirose FH55-22S-0.5SH connector, see the manufacturer data sheet at www.hirose.com.

Handling the actuator

- Move the actuator only between 0° (locked position) to 105° (open position).
- Carefully flip the actuator at the middle with your finger nail, see [Connecting FPC cables to Hirose FPC connectors](#) on page 38.

MIPI CSI-2 FPC cables

FPC cable position

Short circuits of the FPC cable can damage the camera or connected hardware.

- Insert the FPC cable into the connector with cable guiding tabs matching the connector's side guides. See [Connecting FPC cables to Hirose FPC connectors](#) on page 38.
- Connect the camera and the embedded board (adapter) only as shown by the arrow printed on the FPC cable, see [Connecting FPC cables to Hirose FPC connectors](#) on page 38.

FPC cables and stress

Over-stressed FPC cables can damage the camera and connected hardware. When camera and embedded board are twisted against each other or pulled apart from each other with too much force, the FPC cable is over-stressed. Spring contacts of FPC connectors are worn out, causing short circuits and unreliable electrical connections.

- Insert the FPC cable into the FPC connector at 12° to the PCB board surface. See [Connecting FPC cables to Hirose FPC connectors](#) on page 38.
- Allow only slight bending of the FPC cable (minimum bending radius: 10 mm).
- For strain relief, fasten the FPC cable by a cable tie on both cable ends if possible.

No hot-plugging for MIPI CSI-2

Alvium CSI-2 cameras do not support hot-plugging. Hot-plugging can destroy camera and connected hardware by high inrush current.

- Disconnect power supplies before connecting FPC cables.

FPC cables signal quality

Noise and electromagnetic interference can disable camera functions.

- Avoid contact to metal surfaces, causing electromagnetic interference.
- Please use cables recommended by Allied Vision.

Copyright and trademarks

All text, pictures, and graphics are protected by copyright and other laws protecting intellectual property. All content is subject to change without notice.

All trademarks, logos, and brands cited in this document are property and/or copyright material of their respective owners. Use of these trademarks, logos, and brands does not imply endorsement.

Copyright © 2024 Allied Vision Technologies GmbH. All rights reserved.

Specifications



This chapter includes:

| | |
|---|----|
| Specifications: Adapter for Nitrogen6_MAX | 29 |
| Specifications: Adapter for Wandboard i.MX6 | 33 |

Specifications: Adapter for Nitrogen6_MAX

| Feature | Specification |
|---|---|
| Product code | 12314 |
| Dimensions (Length × width × height [mm]) | 51 × 29 × 11.8 |
| Mass (excluding fixing material) | 10 g |
| Storage temperature | -10 °C to +70 °C ambient temperature |
| Temperature range | +5 °C to +65 °C |
| Relative humidity | 0% to 80% (non-condensing) |
| Supported embedded boards | Boundary Devices Nitrogen6_Max boards: <ul style="list-style-type: none"> • Nit6Q_MAX_QCA_BRD i.MX6 Quad • Nit6Q_MAX_QCA_BRD i.MX6 QuadPlus |
| Supported cameras | Alvium CSI-2 cameras |
| Supported FPC cables | Allied Vision 12316, 12317, 12318 |

Table 6: Adapter for Nitrogen6_MAX specifications

Dimensions and PCB layout

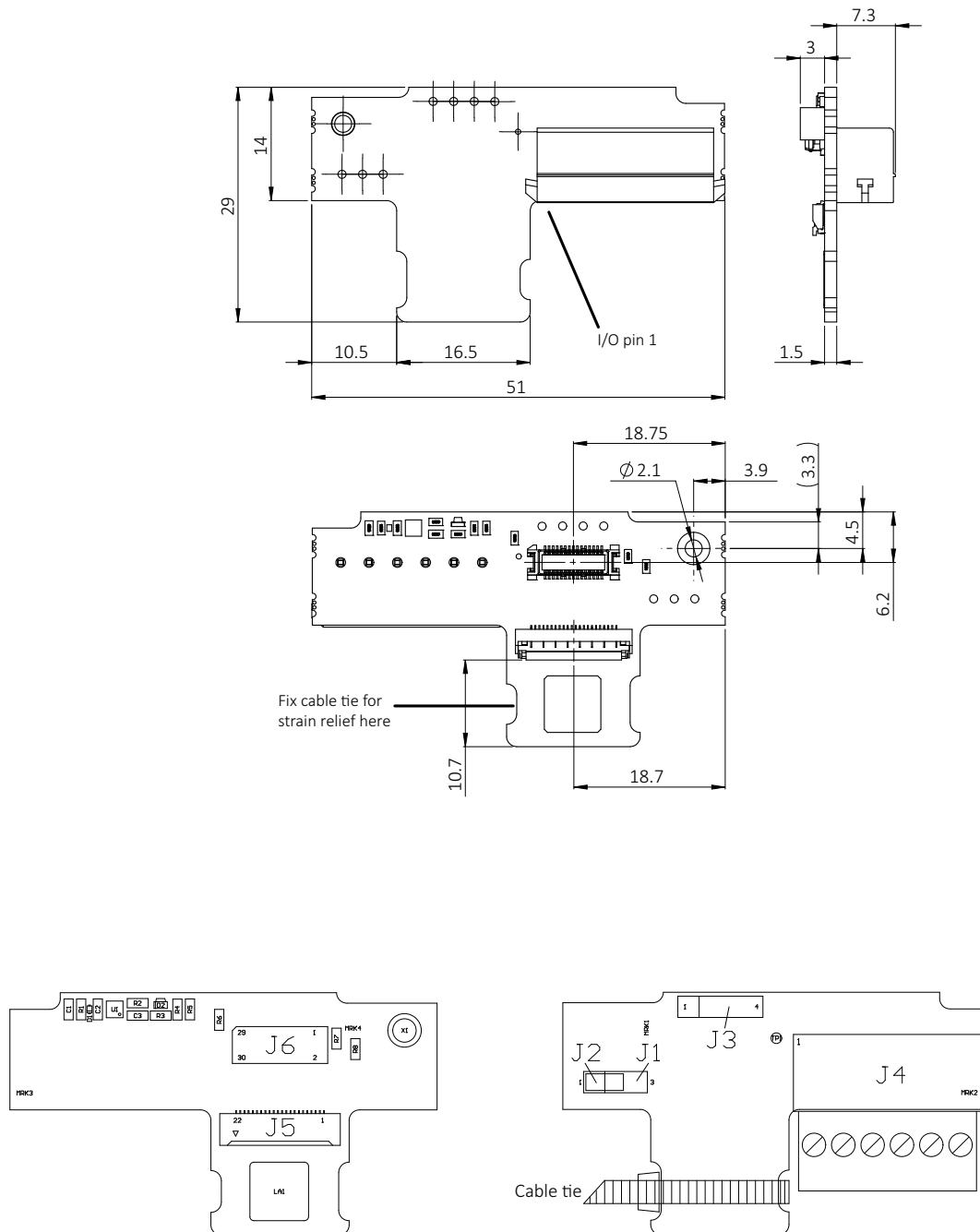

Figure 2: Adapter for Nitrogen6_MAX dimensions and PCB layout

Electronic schematics

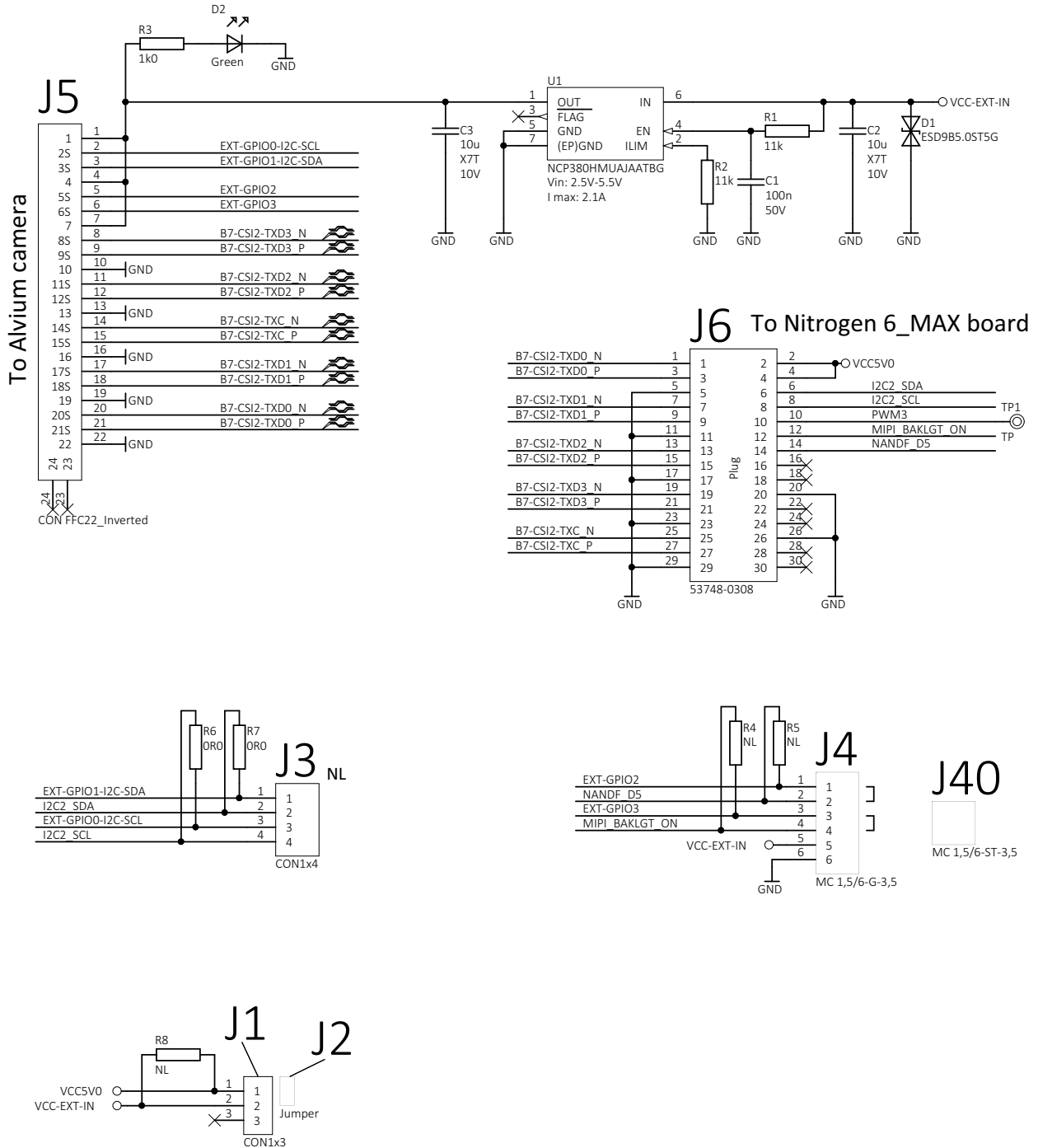

Figure 3: Adapter for Nitrogen6_MAX electronic schematics

I/O screw terminal

You can use the I/O lines to trigger the camera or to output a signal from the camera to trigger a device, such as a strobe light to control illumination.



Information on the terminal screw adapter

For information on the Phoenix MC 1,5/6-G-3,5 I/O terminal adapter, see www.phoenixcontact.com.

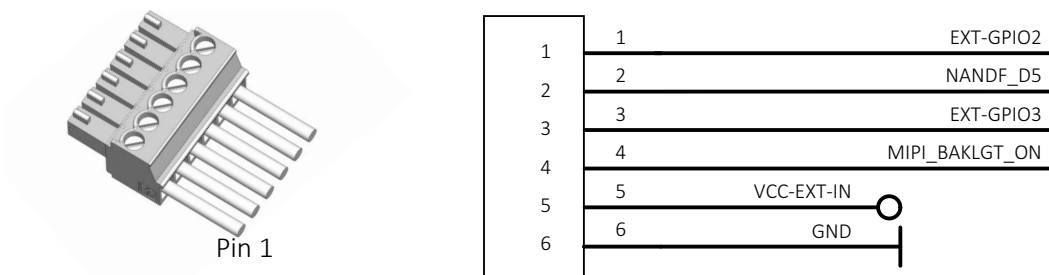

Figure 4: Adapter for Nitrogen6_MAX I/O terminal, wiring diagram

| Pin | Signal | < - > | Level | Description |
|-----|----------------|--------|--|--|
| 1 | EXT-GPIO 2 | IN/OUT | $U_{in} \text{ (low)} = -0.3 \text{ to } 0.8 \text{ VDC}$ $U_{in} \text{ (high)} = 2.0 \text{ to } 5.5 \text{ VDC}$ $U_{out} \text{ (low)} = 0 \text{ to } 0.4 \text{ VDC}$ $U_{out} \text{ (high)} = 2.4 \text{ to } 3.3 \text{ VDC at max. } 12 \text{ mA}$ | GPIO Internal pull-up resistor: 33 kΩ to 63 kΩ |
| 2 | NANDF_D5 | | Please see Nitrogen6_MAX board description by the manufacturer. | |
| 3 | EXT-GPIO 3 | | See EXT-GPIO 2 | |
| 4 | MIPI_BAKLGT_ON | | Please see Nitrogen6_MAX board description by the manufacturer. | |
| 5 | VCC-EXT-IN | PWR IN | 4.5 to 5.5 VDC | Power supply voltage Maximum input current: 1.5 A |
| 6 | GND | PWR | 0 VDC | Power supply ground |

Table 7: Adapter for Nitrogen6_MAX I/O terminal pin assignment



Connections with Nitrogen6_MAX boards

NANDF_D5 and MIPI_BAKLGT_ON lines connect directly to Nitrogen6_MAX board. For manufacturer information, please see www.boundarydevices.com.

Specifications: Adapter for Wandboard i.MX6

| Feature | Specification |
|---|---|
| Product code | 12362 |
| Dimensions (Length × width × height [mm]) | 52 × 40.5 × 10.7 |
| Mass (excluding fixing material) | 6 g |
| Storage temperature | -10 °C to +70 °C ambient temperature |
| Operating temperature | +5 °C to +65 °C |
| Relative humidity | 0% to 80% (non-condensing) |
| Supported embedded board | Wandboard i.MX6 series, revision D: <ul style="list-style-type: none"> • Wandboard Solo (i.MX6) WB-IMX6S-BW • Wandboard Dual (i.MX6) WB-IMX6U-BW • Wandboard Quad (i.MX6) WB-IMX6Q-BW • Wandboard QuadPlus (i.MX6) WB-IMX6QP-BW |
| Supported cameras | Alvium CSI-2 cameras |
| Supported FPC cables | Allied Vision 12316, 12317, 12318 |

Table 8: Adapter for Wandboard i.MX6 specifications

Dimensions and PCB layout

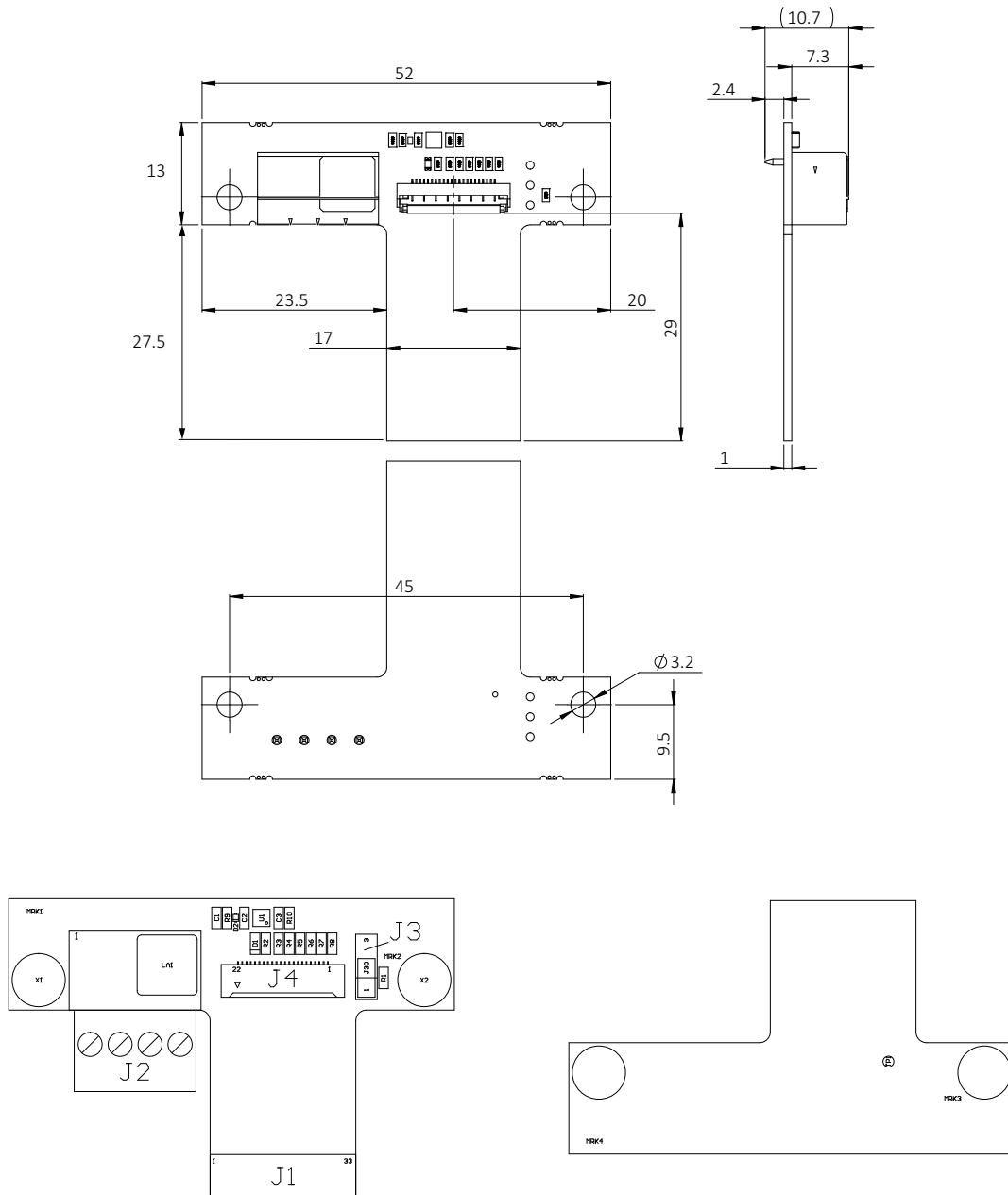

Figure 5: Adapter for Wandboard i.MX6 dimensions and PCB layout

Electronic schematics

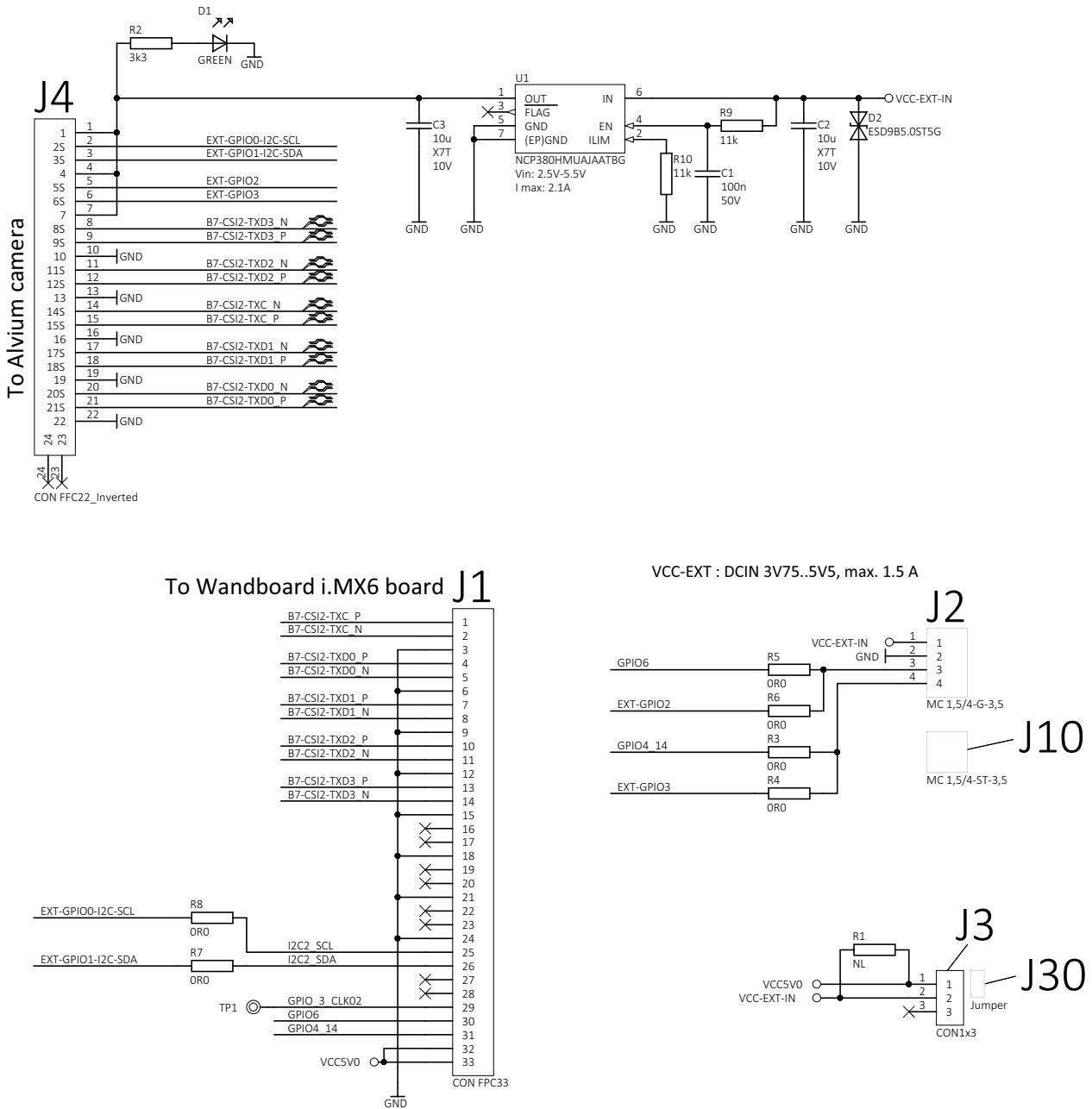

Figure 6: Adapter for Wandboard i.MX6 electronic schematics

I/O screw terminal

You can use the I/O lines to trigger the camera or to output a signal from the camera to trigger a device, such as a strobe light to control illumination.



I/O terminal

For the Phoenix MC 1,5/4-G-3,5 I/O terminal, see: www.phoenixcontact.com.

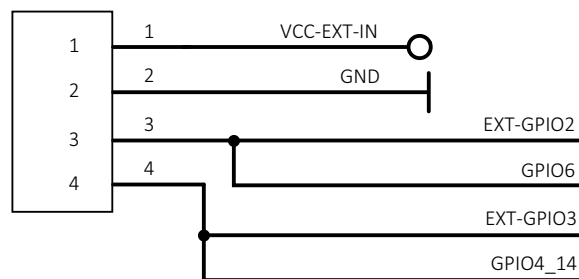
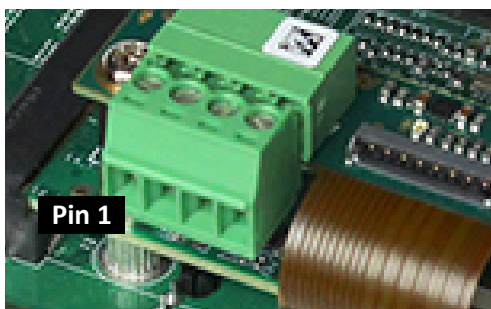

Figure 7: Adapter for Wandboard i.MX6 | I/O terminal, wiring diagram

| Pin | Signal* | < - > | Level | Description |
|-----|-----------------------------------|--------|--|--|
| 1 | VCC-EXT-IN | PWR IN | 4.5 to 5.5 VDC | Power supply voltage Maximum input current: 1.5 A |
| 2 | GND | PWR | 0 VDC | Power supply ground |
| 3 | EXT-GPIO 2 <i>GPIO6</i> | IN/OUT | $U_{in} (low) = -0.3 \text{ to } 0.8 \text{ VDC}$ $U_{in} (high) = 2.0 \text{ to } 5.5 \text{ VDC}$ $U_{out} (low) = 0 \text{ to } 0.4 \text{ VDC}$ $U_{out} (high) = 2.4 \text{ to } 3.3 \text{ VDC at max. } 12 \text{ mA}$ | GPIO Internal pull-up resistor: 33 kΩ to 63 kΩ |
| 4 | EXT-GPIO 3 <i>GPIO4_14</i> | | | See EXT-GPIO 2 |

*Regular style: Alvim camera; *italics: Wandboard i.MX6*

Table 9: Adapter for Wandboard i.MX6 I/O terminal pin assignment



Connections with Wandboard i.MX6 boards

For information on GPIO6 and GPIO_14, please see the manufacturer website: www.wandboard.org.

Using adapter boards



This chapter includes:

| | |
|--|----|
| Embedded system accessories | 38 |
| Connecting FPC cables to Hirose FPC connectors..... | 38 |
| Installing the adapter for Nitrogen6_MAX | 40 |
| Installing adapter boards for Wandboard i.MX6 Solo and Dual..... | 46 |
| Installing adapter boards for Wandboard i.MX6 Quad and QuadPlus. | 49 |
| Setting power modes for Wandboard i.MX6 series | 53 |
| Connecting Wandboard i.MX6 series boards to the camera | 54 |

Embedded system accessories



FPC cables

For more information, see the Alvium Cameras Accessory Guide at www.alliedvision.com/en/support/technical-documentation/alvium-csi-2-documentation.



Designing your own embedded components

If you want to design your own components to connect Alvium CSI-2 cameras to embedded boards, contact your Allied Vision Sales representative or Allied Vision Support at support@alliedvision.com.

Proper usage of the Hirose FH55-22S-0.5SH FPC connector is vital for connecting Alvium CSI-2 cameras to embedded boards. Therefore, instructions start with usage of the FPC connector. Afterwards, setting up the adapter boards is described.

Connecting FPC cables to Hirose FPC connectors

Figure 8 shows how the FPC cable connects to the FPC connector.

Follow the instructions to connect the FPC cable to the camera and to the embedded board.

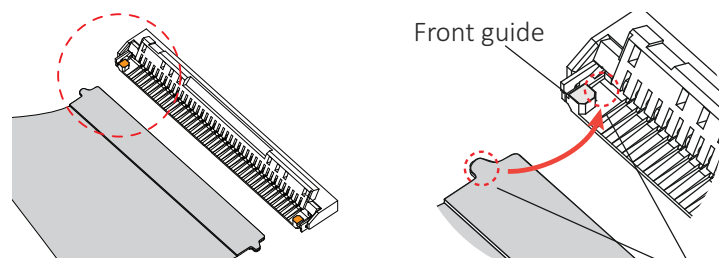

Figure 8: FPC cable and FPC connector (open position)

1. Opening the FPC connector:
With your fingernail*, flip the actuator to open position at 105° to the PCB surface, see Figure 9.

*Or use a plastic tool, as metal tools can damage the actuator.

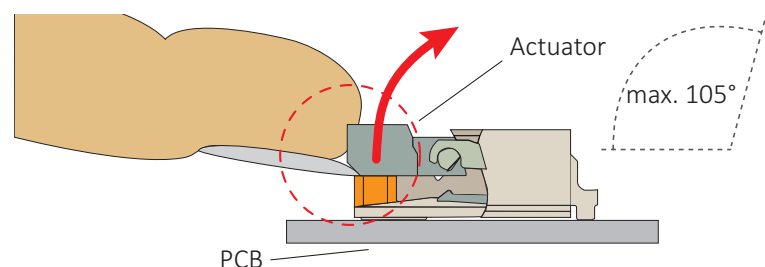

Figure 9: Opening the FPC connector

NOTICE
Damage to the camera by reverse polarity

If Alvium CSI-2 cameras are powered with reverse polarity, camera electronics is damaged.

- Before connecting camera power and I/O power, carefully read the Alvium Cameras User Guide for the FPC connector pin assignment.
- Connect the cable as shown in this section.

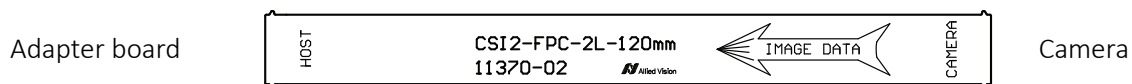

Figure 10: FPC cable image data direction

2. **Ensuring proper cable direction between host and camera**, take the FPC cable with conductors facing the FPC connector conductors (see Figure 11).

3. Inserting the FPC cable:
At a horizontal angle of 90° to the connector's rear (see Figure 11) and at a vertical angle of 12° to the PCB (see Figure 12), slowly insert the FPC cable into the actuator...

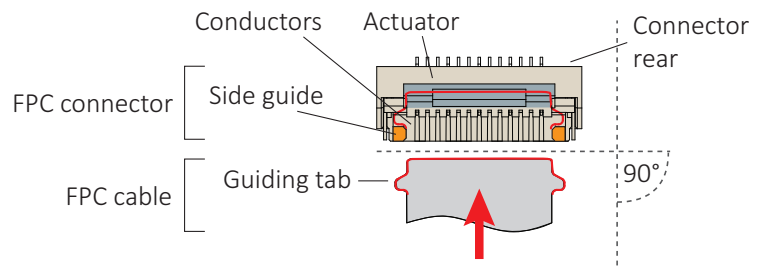

Figure 11: FPC cable and FPC connector

4. ...until cable guiding tabs are caught between connector rear and side guides (see Figure 11). Pull the cable slightly to ensure guiding tabs are properly engaged.
5. Holding the FPC cable in position, flap down the actuator to closed position (see Figure 12).

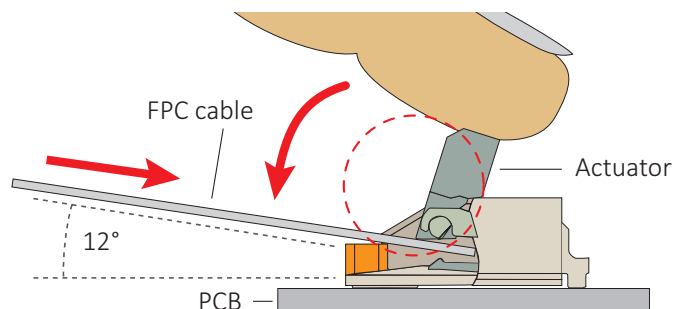

Figure 12: Engaging the FPC cable in the FPC connector

Installing the adapter for Nitrogen6_MAX



NOTICE

Damage to electronics

- Disconnect all power supplies before installing the adapter board to your embedded board.
- Reconnect power only after installation is complete.

Connecting the camera FPC cable

1. Following the instructions in [Connecting FPC cables to Hirose FPC connectors](#) on page 38, connect the FPC cable (b) to the FPC connector (c) of the adapter board (a)...

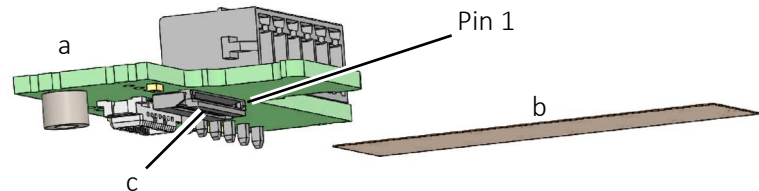

Figure 13: Adapter board and FPC cable

...observe the cable direction: The printed word “host” must point to the FPC connector of the adapter board as shown in [Figure 14](#).

2. Continue with [Fastening the FPC cable with a cable tie](#) on page 41.

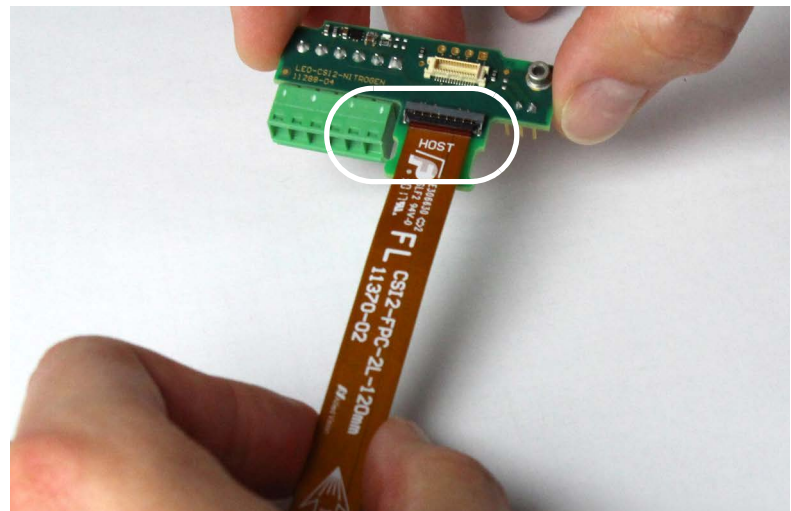

Figure 14: FPC cable being connected to the adapter board

Fastening the FPC cable with a cable tie



NOTICE

Damage to FPC connectors

A bended FPC cable can break the FPC connector's actuator.
Fasten the FPC cable with a cable tie.

1. For strain relief, fasten the FPC cable to the adapter board with a cable tie (a).

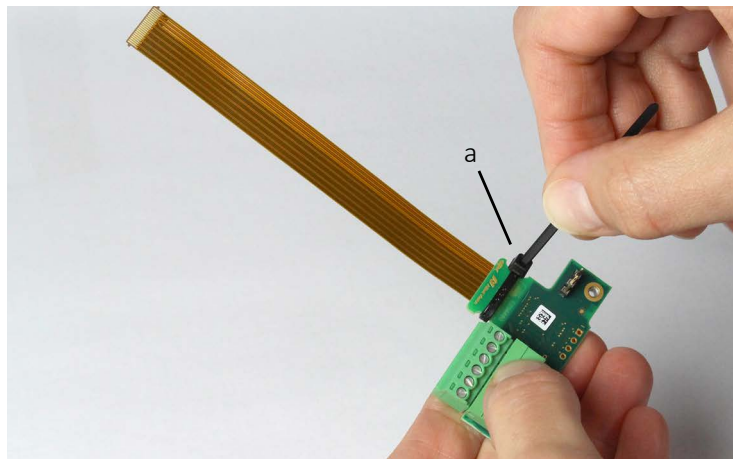

Figure 15: FPC cable being fastened by a cable tie

2. Shorten the cable strap by cutting off the protruding end.

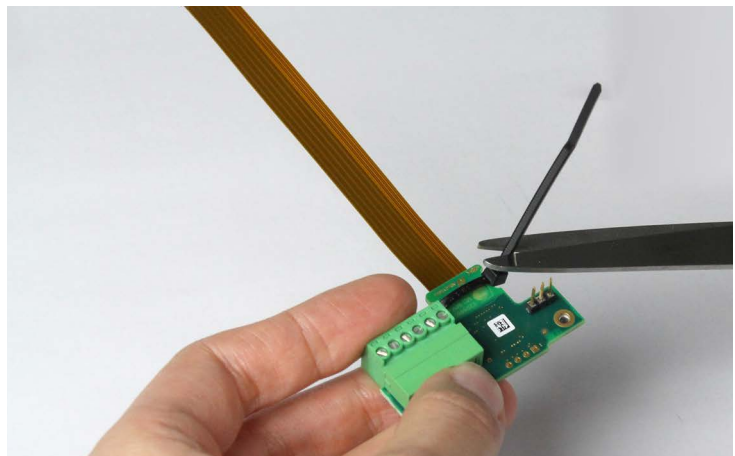

Figure 16: Cable tie being shortened

3. Continue with [Connecting the embedded board](#) on page 42.

Connecting the embedded board

Figure 17 shows how the adapter board is mounted to the Nitrogen6_MAX board:

After the MIPI CSI-2 connectors (g) of the adapter board and of the embedded board have been connected, the bolt (a) is fit through the washer (b) and the spacer sleeve (c) of the adapter board, through the mounting hole (d) of the embedded board, and another washer (e) and connected to the nut (f).

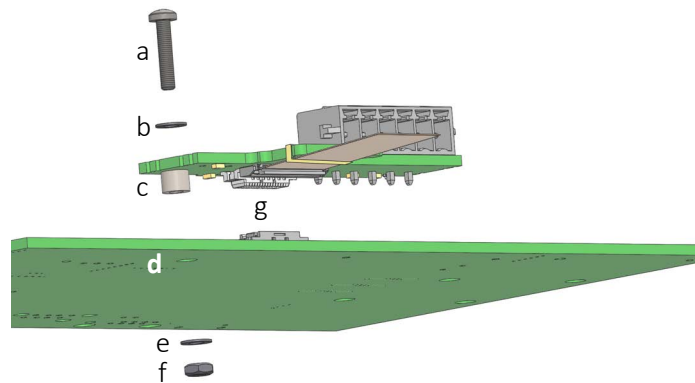

Figure 17: Mounting the adapter board overview

1. Connect the MIPI CSI-2 connector (g) of the adapter board and the MIPI CSI-2 connector (type J16) of the embedded board.

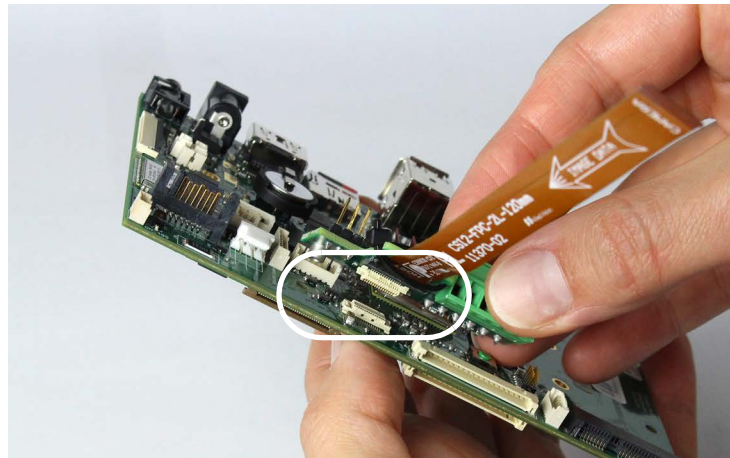

Figure 18: Connecting the MIPI CSI-2 FPC connectors

2. Fit the bolt (a) through the washer (b).
3. Push the bolt through the adapter board's spacer sleeve (c) and through the embedded board's mounting hole (d).
4. Continue with [Tightening the mounting bolt](#) on page 44.

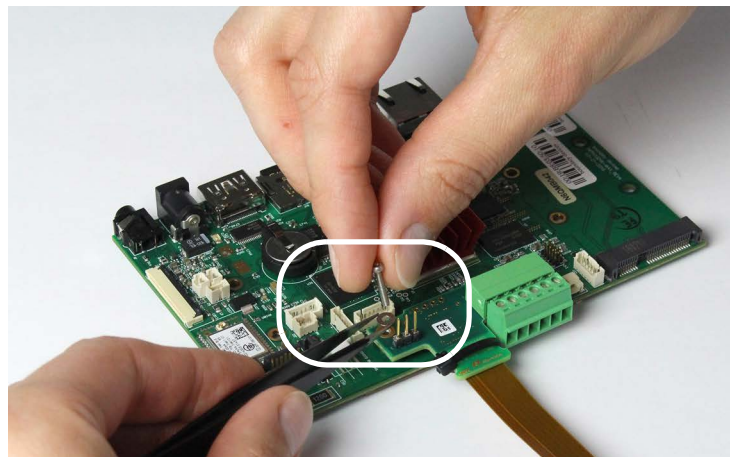

Figure 19: Fitting in the bolt

Tightening the mounting bolt

1. Fit the washer (e) onto the bolt.
2. Fit the nut (f) onto the bolt and thread at 0.3 Nm maximum torque.

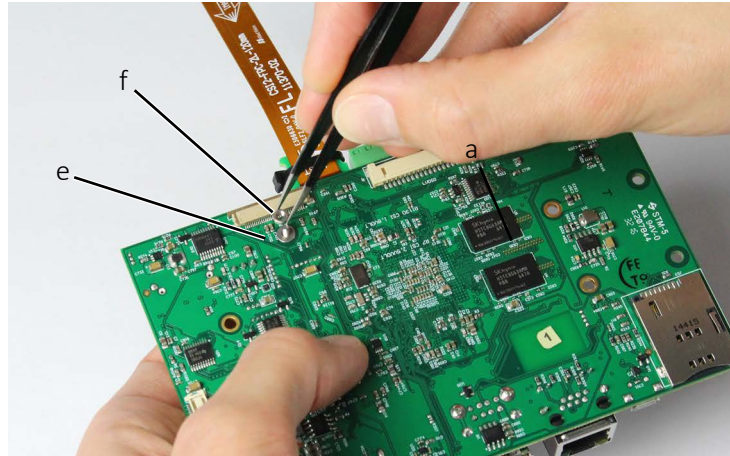

Figure 20: Fitting the washer and nut onto the bolt

3. Continue with [Removing and inserting microSD cards](#) on page 44.

Removing and inserting microSD cards

1. Push the microSD card slightly with your fingertip.
2. Continue with [Setting power modes](#) on page 45.

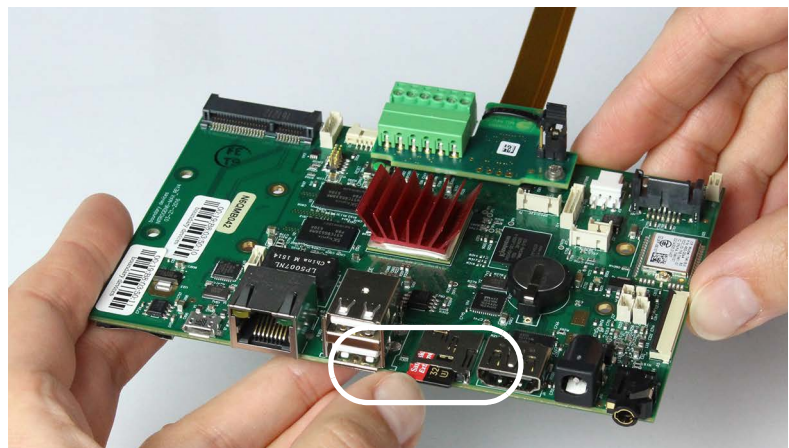

Figure 21: Inserting the microSD card

Setting power modes

1. Set jumper J1 to the corresponding position to select the power mode.

For pin assignment, see [Electronic schematics](#) on page 31.

2. To finally connect the FPC cable to the camera, follow the instructions in [Connecting FPC cables to Hirose FPC connectors](#) on page 38.

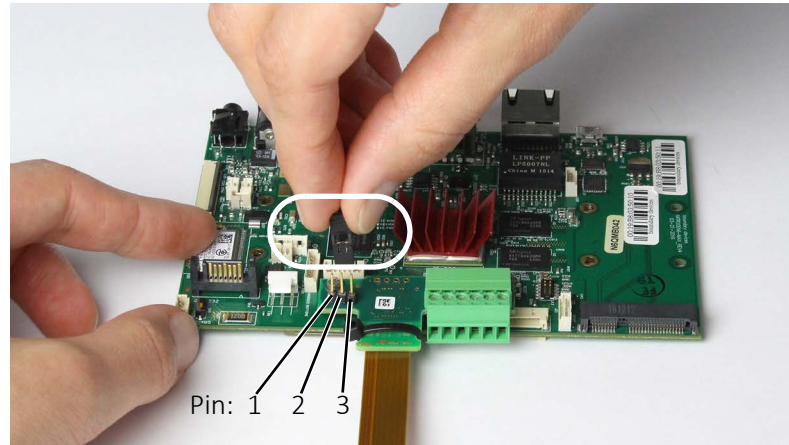

Figure 22: Setting the power mode

Continue with [Connecting the camera](#) on page 45.

| Nitrogen powered | Pin | Externally powered |
|--------------------------|-----|------------------------------|
| Power over Nitrogen6_MAX | 1 | |
| | 2 | Power over the I/Os terminal |
| | 3 | |

Table 10: Jumper position and power modes

Connecting the camera

1. To finally connect the FPC cable to the camera, again follow the instructions in [Connecting FPC cables to Hirose FPC connectors](#) on page 38.
2. Provide strain relief to protect the FPC cable and the FPC connectors from damage and to avoid short circuits.

Your Alvium CSI-2 camera is connected to the embedded board.

Installing adapter boards for Wandboard i.MX6 Solo and Dual



NOTICE

Damage to electronics

- Disconnect all power supplies before installing the adapter board.
- Reconnect power only after installation is complete.



Components in images

Actual fastening material, such as bolts and spacers, may look different than components shown in the instruction images.

Connecting the embedded board

1. Remove the two front bolts (a) of the top board.
Keep the bolts to be reused later.

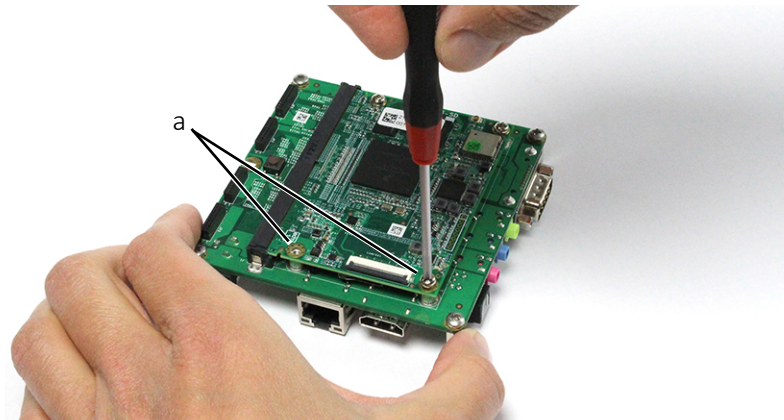

Figure 23: Removing top board bolts

2. Following the instructions in [Connecting FPC cables to Hirose FPC connectors](#) on page 38, connect the FPC cable of the adapter board to FPC connector of the embedded board.

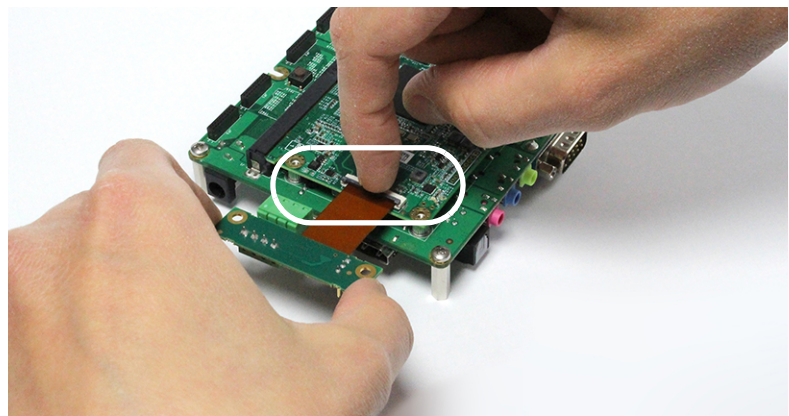

Figure 24: Connecting the adapter board

3. Continue with [Mounting the adapter board](#) on page 47.

Mounting the adapter board

1. Screw in the spacer bolts (a) through the spacer sleeves (b) at 1.2 Nm maximum torque.

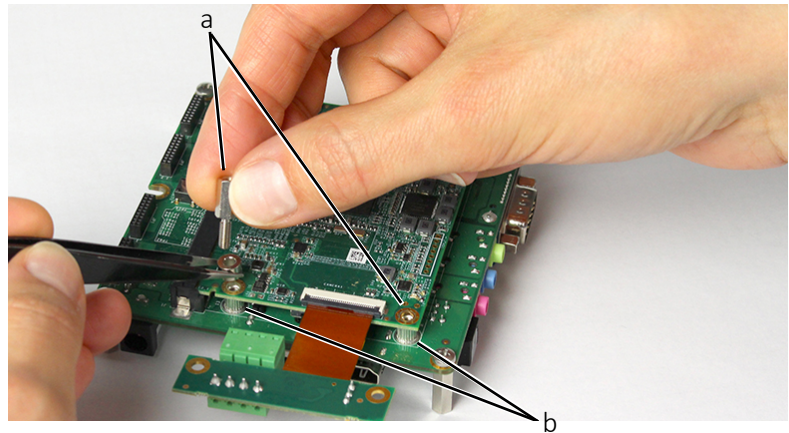

Figure 25: Screwing in the spacer bolts

2. Fold the adapter board until the mounting holes of the adapter board (b) and the spacer bolt (c) match.

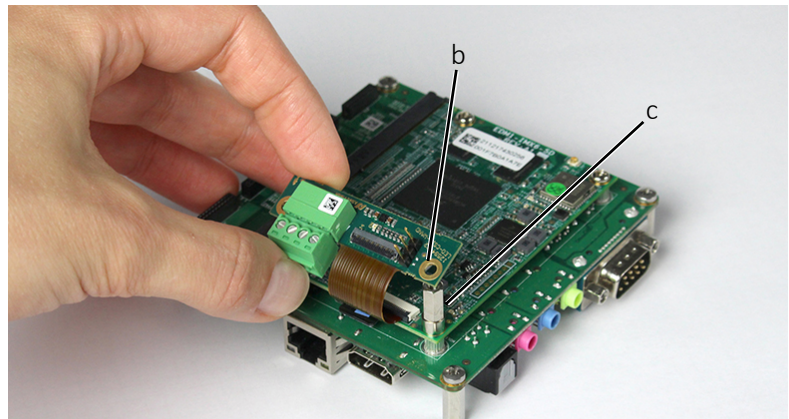

Figure 26: Bringing the adapter board into position

3. Screw in the two bolts (d) you removed before, at 1.2 Nm maximum torque.
4. For **handling microSD cards**, continue with [Removing and inserting microSD cards](#) on page 48.
For **connecting to the camera**, continue with [Connecting Wandboard i.MX6 series boards to the camera](#) on page 54.
For **setting the power mode**, continue with [Setting power modes for Wandboard i.MX6 series](#) on page 53.

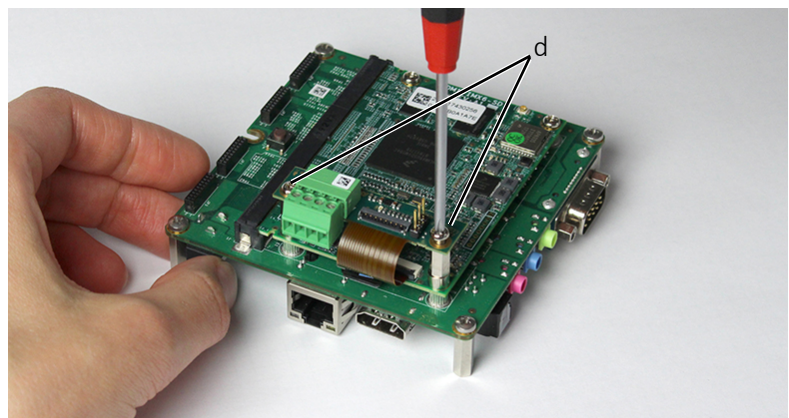

Figure 27: Tightening bolts for the adapter board

Removing and inserting microSD cards



NOTICE

Damage to the FPC cable or to the FPC connector

Keep away from the FPC cable when you remove or insert SD cards.

Push the microSD card slightly with your fingertip.

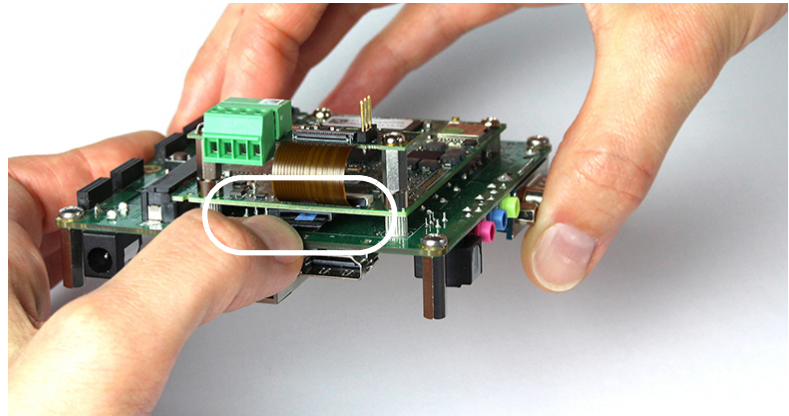

Figure 28: Pushing in the microSD card

Installing adapter boards for Wandboard i.MX6 Quad and QuadPlus



NOTICE

Damage to electronics

- Disconnect all power supplies before installing the adapter board.
- Reconnect power only after installation is complete.



Components in images

Actual fastening material, such as bolts and spacers, may look different than components shown in the instruction images.

Removing the embedded board's heat sink

1. Remove the four bolts (a) holding the heat sink (b). Keep the bolts to be reused later.

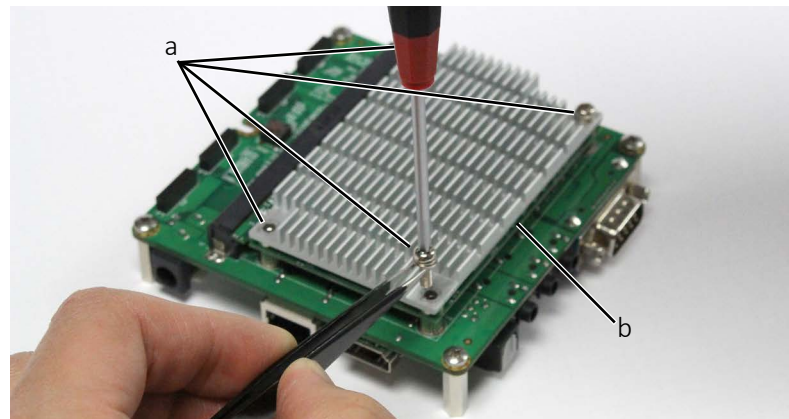

Figure 29: Removing the heat sink bolts

2. Remove the heat sink (b) and the four spacer sleeves (c). Keep the spacer sleeves to be reused later.

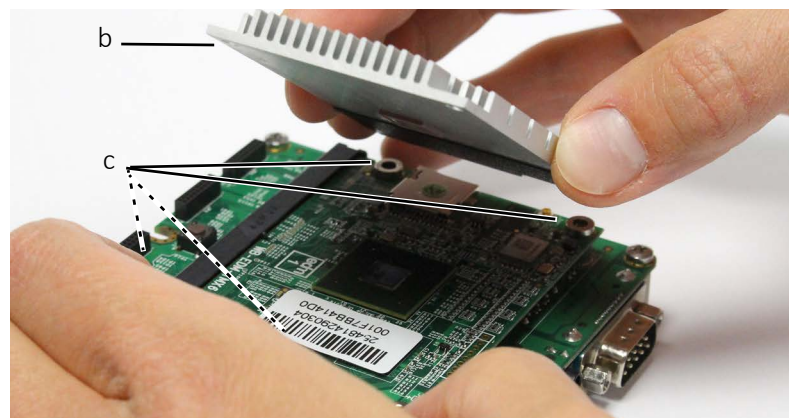

Figure 30: Removing the heat sink and spacer sleeves

3. Continue with [Connecting the embedded board](#) on page 50.

Connecting the embedded board

1. Following the instructions in [Connecting FPC cables to Hirose FPC connectors](#) on page 38, connect the CSI-2 FPC cable of the adapter board to CSI-2 FPC connector the embedded board.



Figure 31: Connecting adapter board and embedded board

2. Position the four spacer sleeves (a) that you removed before back into place.

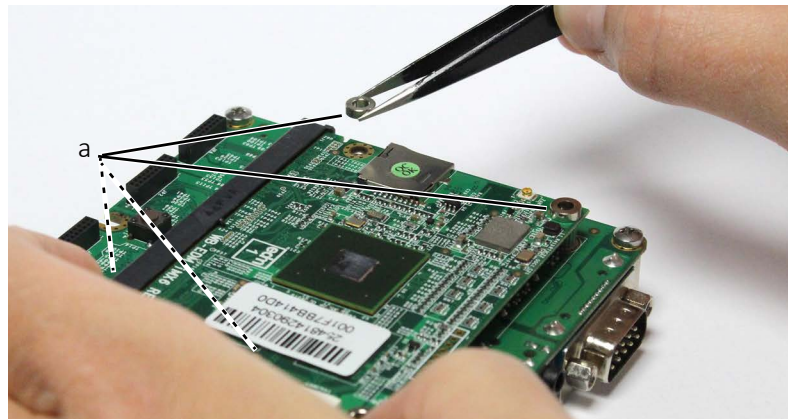

Figure 32: Repositioning the spacer sleeves

3. Place the heat sink onto the spacers with mounting holes matching.
4. Screw in the two back bolts (b) of the heat sink at 1.2 Nm maximum torque.
5. Continue with [Mounting the adapter board](#) on page 51.

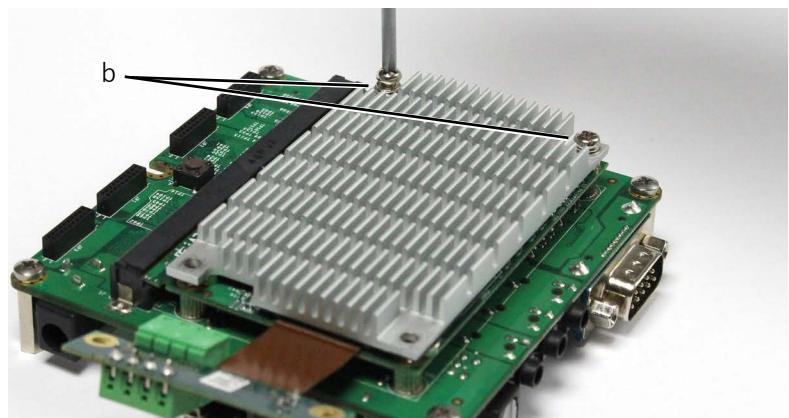

Figure 33: Placing the heat sink and fastening the back bolts

Mounting the adapter board

1. Screw in the spacer bolts (a) at 1.2 Nm maximum torque.

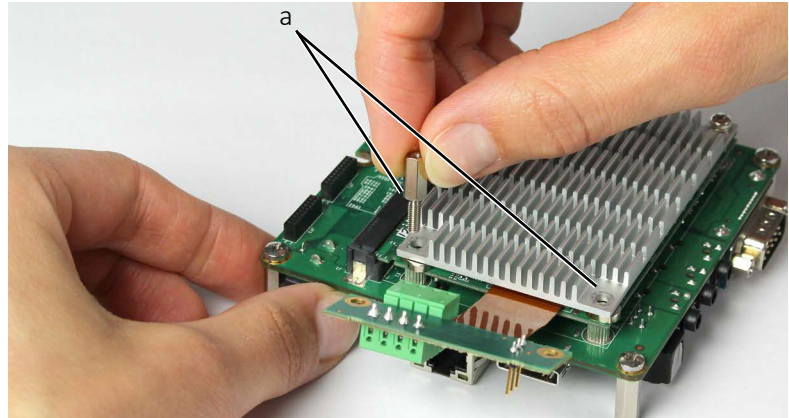

Figure 34: Repositioning the left spacer sleeve on the heat sink

2. Fold the adapter board so that the mounting holes (b) of the adapter board and spacer bolts match.
3. Screw in the bolts (b) you removed before, at 1.2 Nm maximum torque.
4. For **connecting to the camera**, continue with [Connecting Wandboard i.MX6 series boards to the camera](#) on page 54.

For **setting the power mode**, continue with [Setting power modes for Wandboard i.MX6 series](#) on page 53.

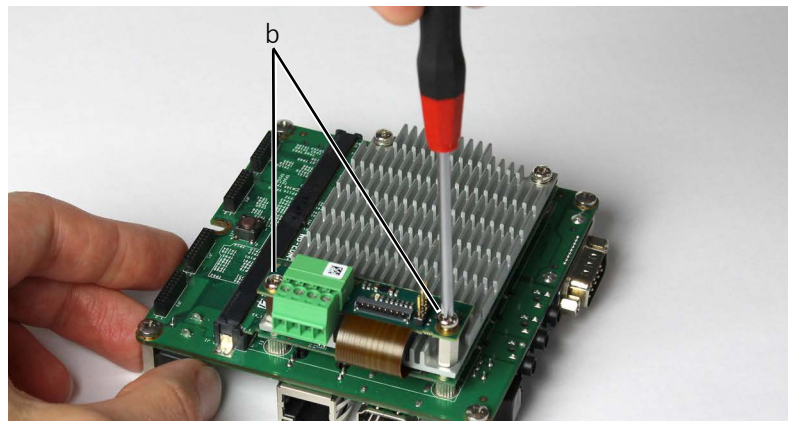

Figure 35: Completing the adapter board mounting

Removing and inserting microSD cards

Push the microSD card slightly with your fingertip.

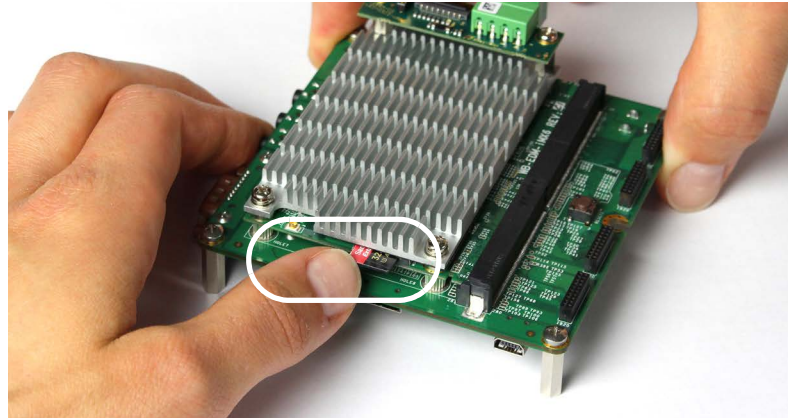

Figure 36: Pushing in the microSD card

Setting power modes for Wandboard i.MX6 series

Set jumper J3 to the corresponding position to select the power mode.

For pin assignment, see [Electronic schematics](#) on page 35.

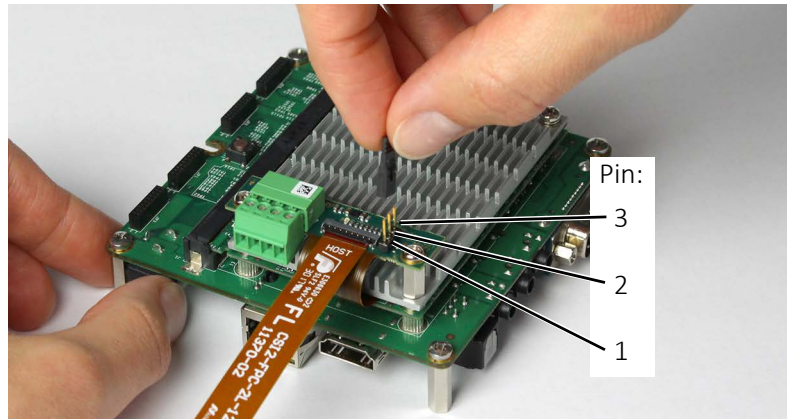

Figure 37: Setting the power mode

| Wandboard powered | Pin | Externally powered |
|----------------------------|-----|------------------------------|
| Power over Wandboard i.MX6 | 1 | |
| | 2 | Power over the I/Os terminal |
| | 3 | |

Table 11: Jumper position and power modes

Connecting Wandboard i.MX6 series boards to the camera

1. Following the instructions in [Connecting FPC cables to Hirose FPC connectors](#) on page 38, connect the FPC cable of the camera to FPC connector the embedded board.
2. To finally connect the FPC cable to the camera, again follow the instructions in [Connecting FPC cables to Hirose FPC connectors](#) on page 38.
3. Provide strain relief to protect the FPC cable and the FPC connectors from damage and to avoid short circuits.

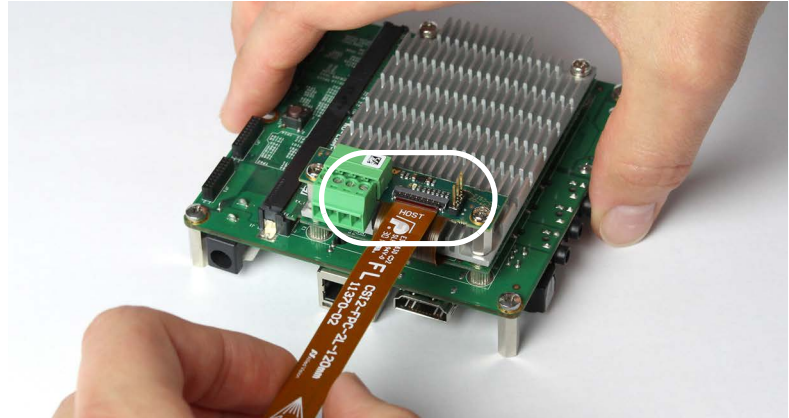

Figure 38: Connecting the camera FPC cable

Your Alvium CSI-2 camera is connected to the embedded board.