



Note: Lenses are not part of this product.

## User Guide

V4.2.3

2023-Dec-19

**Quick links**

- Chapter [Introduction](#) on page 23
- Chapter [Contact us](#) on page 15
- Chapter [Contents](#) on page 16

## Read before use

### EN - English

#### Safety

Before using the camera, read these safety instructions. Observe the warnings at all times. Use the camera only as stated in the Chapter [Intended use](#) on page 38.

**CAUTION****Risk of burns**

A camera in operation can reach temperature levels which could cause burns.

**CAUTION****Injury by falling cameras or lenses**

A falling camera or lens can cause injury.

**CAUTION****Risk of cuts by sharp edges of lens mounts**

The threads of the lens mount can have sharp edges.

#### Intended use

Intended use of Allied Vision product is the integration into vision systems by professionals. All Allied Vision product is sold in a B2B setting.

## DA - Dansk

**Sikkerhed**

Læs sikkerhedsanvisningerne, før kameraet bruges. Overhold alle advarsler. Brug kun kameraet som anført i [Intended use](#) på side 38.

**FORSIGTIG****Forbrændingsfare**

Når kameraet bruges, kan det blive meget varmt og forårsage forbrændinger.

**FORSIGTIG****Kvæstelser, hvis kameraet eller linser falder ned**

Falder kameraet eller linsen ned, kan dette forårsage kvæstelser.

**FORSIGTIG****Fare for snitsår på linsemodulets skarpe kanter**

Linsemodulets gevind kan have skarpe kanter.

**Tilsigtet brug**

Allied Vision produktets tilsigtede brug er en indbygning i et visionssystem, udført af fagfolk. Alle Allied Vision produkter sælges i B2B.

## DE - Deutsch

### Sicherheit

Bevor Sie die Kamera benutzen, lesen diese Sicherheitshinweise. Beachten Sie diese Hinweise immer. Verwenden Sie die Kamera nur wie beschrieben in [Intended use](#) auf Seite 38.

**VORSICHT****Gefahr von Verbrennungen**

Im Betrieb kann die Kamera Temperaturen erreichen, die zu Verbrennungen führen.

**VORSICHT****Verletzung durch fallende Kameras oder Objektive**

Eine fallende Kamera oder ein fallendes Objektiv kann Verletzungen verursachen.

**VORSICHT****Schnitte durch scharfkantige Objektivgewinde**

Objektivgewinde können scharfe Kanten haben.

### Bestimmungsgemäßer Gebrauch

Allied Vision Produkte sind bestimmt für die Integration in Bildverarbeitungssysteme durch Fachpersonal. Alle Allied Vision Produkte werden in einer B2B-Umgebung verkauft.

## ES - Español

## Seguridad

Antes de utilizar la cámara lea estas instrucciones de seguridad. Observe las advertencias en todo momento. Utilice la cámara solo tal y como se estipula en el [Intended use](#) a pagina 38.



### ATENCIÓN

#### Riesgo de quemaduras

Una cámara en funcionamiento puede alcanzar temperaturas que podrían provocar quemaduras.



### ATENCIÓN

#### Lesiones en caso de que las cámaras o las lentes se caigan

Si una cámara o una lente se cae puede provocar lesiones.



### ATENCIÓN

#### Riesgo de cortes debido a los bordes afilados del objetivo

Las roscas de los objetivos pueden tener bordes afilados.

## Uso previsto

El uso previsto del producto Allied Vision es la integración en el sistema de visión por parte de profesionales. Todos los productos Allied Vision se venden dentro de una relación B2B.

## FI - Suomi

**Turvallisuus**

Lue nämä turvallisuusohjeet ennen kameran käyttöä. Noudata varoituksia joka hetki. Käytä kameraa ainoastaan kohdassa [Intended use](#) sivulla 38 kuvatulla tavalla.

**HUOMIO****Palovammojen vaara**

Käytössä olevan kameran saavuttamat lämpötilatasot voivat aiheuttaa palovammoja.

**HUOMIO****Putoavien kameroiden tai linssien aiheuttamat vammat**

Putoava kamera tai linssi voi aiheuttaa vammoja.

**HUOMIO****Linssien kiinnikkeiden terävien reunojen aiheuttamien viiltovammojen vaara**

Linssin kiinnikkeiden kierteiden reunat voivat olla teräviä.

**Käyttötarkoitus**

Allied Vision-tuotteen käyttötarkoitus on integrointi kuvajärjestelmiin ammattilaisten toimesta. Kaikki Allied Vision-tuotteet myydään B2B-ympäristössä.

## FR - Français

### Sécurité

Veillez lire ces consignes de sécurité avant d'utiliser la caméra. Respectez continuellement les avertissements. Utilisez la caméra uniquement comme indiqué sous [Intended use](#), page 38.

**ATTENTION****Risque de brûlures**

Une caméra en service peut atteindre des niveaux de température susceptibles d'entraîner des brûlures.

**ATTENTION****Blessures en cas de chute de caméras ou d'objectifs**

La chute d'une caméra ou d'un objectif peut entraîner des blessures.

**ATTENTION****Risque de coupures sur les bords tranchants des montures d'objectif**

Les filetages des montures d'objectif peuvent présenter des bords tranchants.

### Utilisation prévue

L'utilisation prévue du produit Allied Vision est son intégration dans des systèmes de vision par le soin de professionnels. Tout produit Allied Vision est vendu dans un cadre B2B.

## עברית - HE

### בטיחות

לפני השימוש במצלמה, עליך לקרוא את הוראות הביטחון האלו. עליך לממש הוראות ביטחון אלו תמיד. השימוש במצלמה הוא רק לפי מה שכתוב ב"כוונת השימוש" (Intended use) בעמוד 38.

#### זהירות

##### סכנת כוויה

בזמן הפערת המצלמה עלולות ממפרטורות גבוהות לעלות, שיכולות לגרום לכוויות.



#### זהירות

##### פציעה מנפילת מצלמות או עדשות

מצלמה או עדשה שנופלות עלולות לגרום לפציעה.



#### זהירות

##### סכנה להחתך מתברג חד של העדשה

תברג תושבת העדשה עלול להיות חד עד כדי פציעה.



### שימוש מיועד

מוצרי AlliedVision מיועדים לשילוב במערכות ממוחשבת לעיבוד צילומים ע"י אנשי מקצוע. כל מוצרי AlliedVision נמכרים לשימוש בסביבת B2B.



## IT - Italiano

### Sicurezza

Leggere queste istruzioni per la sicurezza prima di utilizzare la telecamera. Osservare sempre tutte le avvertenze. Utilizzare la telecamera come descritto alla sezione [Intended use](#) a pagina 38.



#### ATTENZIONE

##### **Pericolo di ustioni**

Durante il funzionamento una telecamera può raggiungere temperature elevate che possono essere causa di ustioni.



#### ATTENZIONE

##### **Lesioni dovute alla caduta di telecamere o lenti**

La caduta di una telecamera o di una lente può causare delle lesioni.



#### ATTENZIONE

##### **Pericolo di tagliarsi sui bordi affilati degli attacchi della lente**

I bordi della filettatura dell'attacco della lente possono essere affilati.

### Uso previsto

Il prodotto Allied Vision è concepito per essere integrato in sistemi di monitoraggio in campo professionale. Tutti i prodotti Allied Vision sono venduti in uno scenario B2B.

## JA – 日本語

## 安全性

本カメラを使用する前に、この安全の手引きをお読みください。常に、警告事項を守ってください。必ず、[Intended use 38](#) ページの通りに、本カメラを使用してください。



## 注意

やけどの危険性

作動中のカメラは、やけどを引き起こす温度まで熱くなる恐れがあります。



## 注意

カメラまたはレンズの落下によるけが

カメラまたはレンズが落下すると、けがをする恐れがあります。



## 注意

レンズマウントの鋭利な端部で切り傷の危険性

レンズマウントのギザギザの部分が鋭利である可能性があります。

## 用途

Allied Vision製品は、専門家が視覚装置に統合することを意図したものです。すべてのAllied Vision製品は、企業間取り引き用に販売されています。

## NL - Nederlands

### Veiligheid

Lees deze veiligheidsinstructies voordat u de camera gaat gebruiken. Neem deze waarschuwingen altijd in acht. Gebruik de camera uitsluitend, zoals aangegeven in het [Intended use](#) op pagina 38.



#### VOORZICHTIG

##### Risico van verbranding

Een camera die gebruikt wordt, kan temperatuurwaarden bereiken die brandwonden kunnen veroorzaken.



#### VOORZICHTIG

##### Letsel door vallende camera's of lenzen

Een vallende camera of lens kan letsel veroorzaken.



#### VOORZICHTIG

##### Risico van snijwonden door scherpe randen van lensbevestigingen

Het schroefdraad van de lensbevestiging kan scherpe randen hebben.

### Beoogd gebruik

Het beoogde gebruik van het Allied Vision-product is de integratie in optische systemen door professionals. Alle Allied Vision-producten worden verkocht in de B2B-markt.

## NO - Norsk

**Sikkerhet**

Les disse sikkerhetsinstruksene før du bruker kameraet. Følg advarslene til en hver tid. Bruk kun kameraet i samsvar med [Intended use](#) på side 38.

**FORSIKTIG****Risiko for brannskader**

Et kamera i bruk kan nå temperaturnivåer som kan forårsake brannskader.

**FORSIKTIG****Skade ved fallende kameraer eller linser**

Et fallende kamera eller en fallende linse kan forårsake skade.

**FORSIKTIG****Risiko for kutt fra skarpe kanter på linsefester**

Sporene på linsefestet kan ha skarpe kanter.

**Tiltenkt bruk**

Den tiltenkte bruken av Allied Vision-produktet er integrering i visjonssystemer av profesjonelle. Alle Allied Vision-produkter selges i en forretning til forretningssituasjon.

## SV - Svenska

## Säkerhet

Läs igenom säkerhetsinstruktionerna innan du använder kameran. Var hela tiden särskilt uppmärksam på varningarna. Använd enbart kameran på det sätt som anges i [Intended use](#) på sida 38.

**VARNING****Risk för brännskada**

En kamera i drift kan komma upp i temperaturer som kan orsaka brännskador.

**VARNING****Risk för skador från fallande kameror eller objektiv**

Fallande kameror eller objektiv kan förorsaka skador.

**VARNING****Risk för skärsår från vassa kanter på objektivfattningar**

Objektivets gängor kan ha vassa kanter.

## Avsedd användning

Den avsedda användningen av Allied Vision-produkter är integrering i visionssystem av fackmän. Samtliga Allied Vision-produkter säljs i en B2B-miljö.

## ZH – 简体中文版

### 安全需知

使用本相机前，请阅读本安全说明书。请务必遵守相关警告 和 [Intended use](#) 于第 38 页。



#### 注意事项

##### 烫伤风险

相机操作过程中温度可能上升并导致烫伤风险。



#### 注意事项

##### 相机或者镜头跌落造成伤害

相机或者镜头可能会跌落并造成伤害。



#### 注意事项

##### 镜头接口的锐利边缘划伤风险

镜头接口螺纹边缘可能较为锐利。

### 预期用途

Allied Vision 产品的预期用途是由专业人士整合到视觉系统中。所有 Allied Vision 的产品均通过 B2B 渠道销售。

## Contact us

### Website, email

#### General

[www.alliedvision.com/en/contact](http://www.alliedvision.com/en/contact)  
[info@alliedvision.com](mailto:info@alliedvision.com)

#### Distribution partners

[www.alliedvision.com/en/avt-locations/avt-distributors](http://www.alliedvision.com/en/avt-locations/avt-distributors)

#### Support

[www.alliedvision.com/en/support](http://www.alliedvision.com/en/support)  
[www.alliedvision.com/en/about-us/contact-us/technical-support-repair/-/rma](http://www.alliedvision.com/en/about-us/contact-us/technical-support-repair/-/rma)

### Offices

#### Europe, Middle East, and Africa (Headquarters)

Allied Vision Technologies GmbH  
Taschenweg 2a  
07646 Stadtroda, Germany  
T// +49 36428 677-0 (Reception)  
T// +49 36428 677-230 (Sales)  
F// +49 36428 677-28

#### Asia-Pacific

##### China

Allied Vision Technologies  
(Shanghai) Co., Ltd.  
2-2109 Hongwell Int. Plaza  
1602# ZhongShanXi Road  
Shanghai 200235, China  
T// +86 21 64861133

##### Singapore

Allied Vision Technologies Asia Pte. Ltd  
82 Playfair Rd, #07-01 D'Lithium  
Singapore 368001  
T// +65 6634 9027

#### North, Central, and South America

##### Canada

Allied Vision Technologies Canada Inc.  
300 – 4621 Canada Way  
Burnaby, BC V5G 4X8, Canada  
T// +1 604 875 8855

##### USA

Allied Vision Technologies, Inc.  
102 Pickering Way- Suite 502  
Exton, PA 19341, USA  
Toll-free// +1-877-USA-1394  
T// +1 978 225 2030

# Contents

<b>Read before use</b> .....	2
EN - English .....	2
DA - Dansk.....	3
DE - Deutsch.....	4
ES - Español.....	5
FI - Suomi .....	6
FR - Français.....	7
HE - עברית.....	8
IT - Italiano .....	9
JA – 日本語	10
NL - Nederlands .....	11
NO - Norsk.....	12
SV - Svenska .....	13
ZH – 简体中文版	14
<b>Contact us</b> .....	15
Website, email .....	15
Offices .....	15
<b>Introduction</b> .....	23
Document history .....	23
Manual overview .....	31
Conventions used in this manual .....	33
Styles.....	33
More information .....	34
Before operation .....	34
<b>Guppy PRO cameras</b> .....	36
<b>Compliance, safety, and intended use</b> .....	37
Compliance notifications .....	37
For customers in China and Europe.....	37
For customers in the USA.....	37
FCC Class B digital device .....	37
United States of America: Supplier Declaration of Conformity .....	37
Party issuing Supplier's Declaration of Conformity .....	37
Responsible Party - U.S. Contact Information .....	38
For customers in Canada.....	38
Pour utilisateurs au Canada .....	38
Avoid electromagnetic interferences .....	38
Intended use .....	38
Copyright and trademarks.....	39
Your safety .....	39



Handling lens mounts.....	39
Handling hot cameras .....	39
Providing optimum heat dissipation .....	39
Camera mounting.....	39
Avoiding material damage.....	40
Electronics maintenance .....	40
Cable connections .....	40
Powering cameras.....	40
No hot plugging.....	40
Avoiding electrostatic discharge (ESD) .....	40
Maximum inrush current .....	41
Suitable accessories .....	41
Cleaning cameras .....	41
Warranty note .....	41
<b>FireWire.....</b>	<b>42</b>
Overview .....	42
Definition .....	42
IEEE1394 standards.....	42
Why use FireWire? .....	43
FireWire in detail .....	43
Serial bus .....	43
FireWire connection capabilities.....	44
Capabilities of IEEE1394a (FireWire 400) .....	45
IIDC V1.3 camera control standards .....	45
Capabilities of IEEE1394b (FireWire 800) .....	45
IIDC V1.31 camera control standards .....	45
Compatibility between IEEE1394a and IEEE1394b .....	46
Compatibility example .....	46
Image transfer via IEEE1394a and IEEE1394b .....	47
IEEE1394b bandwidths.....	47
Requirements for PC and IEEE1394b.....	48
Example 1: IEEE1394b bandwidth of Guppy PRO cameras.....	48
Example 2: More than one Guppy PRO camera at full speed.....	49
FireWire Plug & play capabilities.....	49
FireWire hot-plug and screw-lock precautions.....	50
Operating system support.....	51
<b>Specifications.....</b>	<b>52</b>
Guppy PRO F-031B, F-031C.....	53
Guppy PRO F-032B, F-032C .....	54
Guppy PRO F-033B, F-033C .....	55
Guppy PRO F-046B, F-046C.....	56
Guppy PRO F-125B, F-125C .....	57
Guppy PRO F-146B, F-146C .....	58
Guppy PRO F-201B, F-201C.....	59
Guppy PRO F-503B, F-503C .....	60
Spectral sensitivity.....	61

Absolute quantum efficiency (QE) .....	61
Spectral response plots .....	61
Guppy PRO F-031B, F-031C.....	62
Guppy PRO F-032B, F-032C.....	63
Guppy PRO F-033B, F-033C.....	64
Guppy PRO F-046B, F-046C.....	65
Guppy PRO F-125B, F-125C.....	66
Guppy PRO F-146B, F-146C.....	67
Guppy PRO F-201B, F-201C.....	68
Guppy PRO F-503B, F-503C.....	69
<b>Camera dimensions .....</b>	<b>70</b>
Guppy PRO standard housing (1 × IEEE1394b copper) .....	70
Tripod adapter .....	71
Maximum protrusion: C-Mount .....	72
Maximum protrusion: CS-Mount .....	73
Adjustment of C-Mount/CS-Mount.....	74
<b>Filter and lenses .....</b>	<b>75</b>
IR cut filter: spectral transmission.....	75
Camera lenses.....	75
Guppy PRO F-031 .....	76
Guppy PRO F-032 .....	76
Guppy PRO F-033, F-046, F-146.....	77
Guppy PRO F-201 .....	77
Guppy PRO F-503 .....	78
<b>Camera interfaces .....</b>	<b>79</b>
IEEE1394b port pin assignment .....	79
Camera I/O connections.....	80
Status LEDs.....	82
Normal conditions .....	82
Error conditions.....	83
Control and video data signals .....	84
Inputs .....	84
Triggers.....	84
Input/output pin control .....	85
IO_INP_CTRL 1 .....	85
Trigger delay.....	86
Outputs.....	88
IO_OUTP_CTRL 1-3.....	89
Output modes .....	90
Pulse-width modulation .....	91
PWM: minimum and maximum periods and frequencies .....	92
PWM: Examples in practice .....	93
Pixel data.....	93
Description of video data formats .....	94

<b>Description of the data path</b> .....	98
Block diagrams of Guppy PRO models .....	98
Monochrome models.....	98
Color models.....	99
White balance .....	99
One-push white balance .....	101
Auto white balance (AWB) .....	102
Auto shutter .....	104
Auto gain .....	105
Manual gain .....	108
Brightness (black level or offset) .....	108
Mirror function (Guppy PRO F-503B, F-503C) .....	109
Look-up table (LUT) and gamma function .....	110
Loading an LUT into the camera .....	111
Defect pixel correction (Guppy PRO F-503B, F-503C) .....	113
Building defect pixel data .....	114
Grab an image with defect pixel data.....	115
Calculate defect pixel coordinates.....	115
Reset values (resolution, shutter, gain, brightness).....	115
Activate/deactivate defect pixel correction .....	116
Store defect pixel data non-volatile.....	116
Load non-volatile stored defect pixel data .....	116
Send defect pixel data to the host .....	116
Receive defect pixel data from the host.....	116
Binning (monochrome CCD models and Guppy PRO F-503B, F-503C) .....	116
2 × binning (Guppy PRO F-503 also 4 ×) .....	116
Vertical binning.....	117
Horizontal binning .....	119
2 × full binning (Guppy PRO F-503 also 4 × full binning) .....	121
Sub-sampling (Guppy PRO F-503B, F-503C and monochrome CCD models).....	123
What is sub-sampling? .....	123
Which Guppy PRO models have sub-sampling? .....	123
Description of sub-sampling.....	123
Binning and sub-sampling access (Guppy PRO F-503B, F-503C, and monochrome CCD models) .	127
Packed 12-Bit Mode .....	130
Color interpolation (Bayer demosaicing) .....	130
Hue and saturation .....	132
Color correction .....	132
Why color correction? .....	132
Color correction in Allied Vision cameras.....	133
Color correction: formula .....	133
GretagMacbeth ColorChecker .....	133
Changing color correction coefficients.....	133
Switch color correction on/off.....	134
Color conversion (RGB to YUV) .....	135
Bulk trigger.....	135
Level trigger .....	135

<b>Controlling image capture</b> .....	136
Global shutter (CCD cameras only) .....	136
Electronic rolling shutter (ERS) and global reset release shutter (GRR) (Guppy PRO F-503 only)..	137
Trigger modes .....	138
Trigger_Mode_0 (edge mode) and Trigger_Mode_1 (level mode) .....	139
Guppy PRO F-503, Trigger_Mode_0, electronic rolling shutter.....	139
Guppy PRO F-503, Trigger_Mode_0, global reset release shutter .....	141
Bulk trigger (Trigger_Mode_15).....	141
Trigger delay .....	144
Trigger delay advanced register.....	146
Software trigger.....	147
Debounce .....	147
Debounce time .....	148
Exposure time (shutter) and offset .....	149
Exposure time of Guppy PRO F-503.....	149
Exposure time offset .....	149
Minimum exposure time .....	150
Example: Guppy PRO F-031 .....	150
Extended shutter .....	151
One-shot .....	151
One-shot command on the bus to start of exposure .....	152
End of exposure to first packet on the bus.....	153
Multi-shot .....	155
ISO_Enable / free-run .....	155
Asynchronous broadcast .....	155
Jitter at start of exposure .....	156
<b>Video formats, modes and bandwidth</b> .....	158
Guppy PRO F-031B, F-031C.....	159
Guppy PRO F-032B, F-032C.....	161
Guppy PRO F-033B, F-033C.....	163
Guppy PRO F-046B, F-046C.....	165
Guppy PRO F-125B, F-125C.....	167
Guppy PRO F-146B, F-146C.....	169
Guppy PRO F-201B, F-201C.....	171
Guppy PRO F-503B, F-503C.....	173
Area of interest (AOI).....	175
Autofunction AOI.....	177
Frame rates.....	178
Frame rates Format_7.....	182
Guppy PRO F-031: AOI frame rates.....	183
Guppy PRO F-032: AOI frame rates.....	184
Guppy PRO F-033: AOI frame rates.....	185
Guppy PRO F-046: AOI frame rates.....	186
Guppy PRO F-125: AOI frame rates.....	187
Guppy PRO F-146: AOI frame rates.....	188
Guppy PRO F-201: AOI frame rates.....	189

Guppy PRO F-503: AOI frame rates.....	190
<b>How does bandwidth affect the frame rate? .....</b>	<b>192</b>
Example formula for the monochrome camera.....	193
Test images.....	193
Loading test images.....	193
Test images for monochrome models.....	193
Test images for color models.....	194
YUV4:2:2 mode .....	194
Mono8 (raw data) .....	194
<b>Configuration of the camera .....</b>	<b>195</b>
Camera_Status_Register .....	195
Example .....	196
Sample program .....	197
Example FireGrab.....	197
Example FireStack API.....	198
Configuration ROM.....	198
Implemented registers (IIDC V1.31).....	201
Camera initialize register.....	201
Inquiry register for video format .....	201
Inquiry register for video mode .....	202
Inquiry register for video frame rate and base address .....	203
Inquiry register for basic function.....	212
Inquiry register for feature presence.....	213
Inquiry register for feature elements .....	215
Status and control registers for camera .....	218
Inquiry register for absolute value CSR offset address.....	218
Status and control register for one-push.....	219
Feature control error status register .....	222
Video mode control and status registers for Format_7 .....	222
Quadlet offset Format_7 Mode_0.....	222
Quadlet offset Format_7 Mode_1.....	223
Format_7 control and status register (CSR) .....	223
Advanced features (Allied Vision-specific) .....	224
Advanced registers summary.....	224
Extended version information register .....	227
Advanced feature inquiry.....	228
Camera status.....	230
Maximum resolution .....	231
Time base.....	232
Extended shutter .....	233
Test images.....	234
Look-up tables (LUT) .....	235
Loading a look-up table into the camera.....	237
Defect pixel correction .....	237
Input/output pin control .....	239
Delayed Integration Enable (IntEna).....	239

Auto shutter control.....	240
Auto gain control.....	241
Autofunction AOI.....	242
Color correction.....	243
Trigger delay.....	244
Mirror image.....	245
Soft reset .....	245
Maximum ISO packet size .....	246
Format_7 mode mapping (only Guppy PRO F-503) .....	248
Example .....	249
Low-noise binning mode (2 × and 4 × binning) (Guppy PRO F-503 only) .....	249
Software feature control (disable LED).....	249
Disable LEDs .....	249
User profiles .....	250
Error codes .....	252
Reset of error codes.....	252
Stored settings .....	252
Pulse-width modulation (PWM).....	254
Global reset release shutter (Guppy PRO F-503 only).....	254
Gpdata_BUFFER.....	254
Little endian vs. big endian byte order .....	255
<b>Firmware update .....</b>	<b>256</b>
Extended version number (FPGA/μC) .....	256
<b>Appendix.....</b>	<b>257</b>
Sensor position accuracy of Guppy PRO cameras .....	257
<b>Index.....</b>	<b>258</b>

## Introduction

This Guppy PRO Technical Manual describes in depth the technical specifications, dimensions, all camera features (IIDC standard and Allied Vision smart features) and their registers, trigger features, all video and color formats, bandwidth and frame rate calculation.

For information on hardware installation, safety warnings, pin assignments on I/O connectors and IEEE1394b connectors read the *1394 Installation Manual*.

**Note** Please read through this manual carefully



We assume that you have read already the *1394 Installation Manual* (go to [www.alliedvision.com/en/support/technical-documentation](http://www.alliedvision.com/en/support/technical-documentation)) and that you have installed the hardware and software on your PC or laptop (FireWire card, cables).

## Document history

Version	Date	Remarks
V2.0.1	2010-Nov-30	New Manual — Release status
V2.0.2	2011-Apr-05	<ul style="list-style-type: none"> <li>Revised video formats of Guppy PRO F-503, <a href="#">Table 86: Video Format_7 default modes Guppy PRO F-503B, F-503C</a> on page 174</li> <li>Added exposure time offset for Guppy PRO F-503, <a href="#">Table 64: Model-specific exposure time offset</a> on page 150</li> <li>Added On request: power out 6 W (Hirose) in all specification tables: see <a href="#">Specifications</a> on page 52 to 60</li> <li>Revised advanced register: input control (only one input) in <a href="#">Table 23: Advanced register: Input control</a> on page 85</li> <li>Revised IO_INP_CTRL: ID 0x3..0x1F is Reserved in <a href="#">Table 24: Input routing</a> on page 85</li> <li>Revised advanced register: output control (3 outputs) in <a href="#">Table 29: Advanced register: Output control</a> on page 89</li> <li>At register 0xF1000200 changed width and height: see <a href="#">Table 126: Advanced register: Maximum resolution inquiry</a> on page 232</li> <li>YUV8: deleted description of data type straight binary: <a href="#">Table 40: Data structure of YUV8; Source: IIDC V1.31</a> on page 97</li> </ul>
to be continued on next page		

Table 1: Document history

Version	Date	Remarks
[Continued] V2.0.2	[Continued] 2011-Apr-05	<ul style="list-style-type: none"> <li>• Y (Mono8/Raw8) are Allied Vision own formats: see <a href="#">Table 36: Y (Mono8) format: Source: IIDC V1.31 / Y (Raw8) format: Allied Vision</a> on page 95</li> <li>• Video data formats now with subscript letters instead of underscore as wrongly used in IIDC, see <a href="#">Description of video data formats</a> on page 94</li> <li>• Revised absolute QE for Guppy PRO F-031C: see <a href="#">Figure 5: Guppy PRO F-031B, F-031C (Sony ICX618) absolute QE</a> on page 62</li> <li>• Defect pixel correction: you do not need to set value for brightness to max. anymore: see <a href="#">Figure 41: Defect pixel correction: build and store</a> on page 114 and <a href="#">Grab an image with defect pixel data</a> on page 115</li> <li>• Maximum resolution of Guppy PRO F-503B, F503C changed from 2592 × 1944 to 2588 × 1940: see <a href="#">Guppy PRO F-503B, F-503C</a> on page 60 and <a href="#">Video Format_7 default modes Guppy PRO F-503B, F-503C</a> on page 174</li> <li>• Added Guppy PRO F-503 frame rate and bandwidth: see <a href="#">Table 4: Bandwidth of Guppy PRO models</a> on page 48</li> <li>• Changed maximum resolution of Guppy PRO F-503 from 2592 × 1944 to 2588 × 1940: see <a href="#">Guppy PRO F-503B, F-503C</a> on page 60</li> </ul> <p>Guppy PRO F-503:</p> <ul style="list-style-type: none"> <li>• Mono8, YUV411 and YUV422 now in all F7 modes available: see <a href="#">Guppy PRO F-503B, F-503C</a> on page 60</li> <li>• Added minimum exposure time in <a href="#">Table 65: Model-specific minimum exposure time</a> on page 150</li> <li>• Added shutter speed at full resolution: see <a href="#">Guppy PRO F-503B, F-503C</a> on page 60</li> <li>• Added shutter speed: see <a href="#">Guppy PRO F-503B, F-503C</a> on page 60</li> <li>• Binning and sub-sampling in all F7 modes for monochrome and color models: see <a href="#">Guppy PRO F-503B, F-503C</a> on page 60</li> <li>• Added 800 Mbit/s: see <a href="#">Guppy PRO F-503B, F-503C</a> on page 60</li> <li>• Added exposure time for long-term integration (extended shutter) up to 22 seconds: see <a href="#">Extended shutter</a> on page 151</li> <li>• Revised <a href="#">Mirror function (Guppy PRO F-503B, F-503C)</a> on page 109</li> <li>• Manual gain range now 8 to 48 (instead of 60): see <a href="#">Manual gain</a> on page 108</li> <li>• Manual gain range in dB now 0 to 18 dB (instead of 26 dB): see</li> </ul>
V2.0.3	2011-Apr-08	Revised <a href="#">Binning (monochrome CCD models and Guppy PRO F-503B, F-503C)</a> on page 116

Table 1: Document history (continued)



Version	Date	Remarks
V3.0.2	2012-May-18	<p>Changed effective minimum exposure time of Guppy PRO F-031 from 27 <math>\mu</math>s to 75 <math>\mu</math>s:</p> <ul style="list-style-type: none"> <li>• <a href="#">Guppy PRO F-031B, F-031C</a></li> <li>• <a href="#">Example: Guppy PRO F-031</a></li> <li>• <a href="#">End of exposure to first packet on the bus</a></li> </ul> <p>Changed effective minimum exposure time of Guppy PRO F-032 from 27 <math>\mu</math>s to 37 <math>\mu</math>s:</p> <ul style="list-style-type: none"> <li>• <a href="#">Guppy PRO F-032B, F-032C</a></li> <li>• Changed frame rate from 79 fps to 82 fps</li> <li>• <a href="#">Minimum exposure time</a></li> <li>• <a href="#">End of exposure to first packet on the bus</a></li> </ul> <p>Changed effective minimum exposure time of Guppy PRO F-125 from 35 <math>\mu</math>s to 39 <math>\mu</math>s:</p> <ul style="list-style-type: none"> <li>• <a href="#">Guppy PRO F-125B, F-125C</a></li> <li>• <a href="#">Minimum exposure time</a></li> <li>• <a href="#">End of exposure to first packet on the bus</a></li> </ul> <p>Changed effective minimum exposure time of Guppy PRO F-146 from 35 <math>\mu</math>s to 45 <math>\mu</math>s:</p> <ul style="list-style-type: none"> <li>• <a href="#">Guppy PRO F-146B, F-146C</a></li> <li>• <a href="#">Minimum exposure time</a></li> <li>• <a href="#">End of exposure to first packet on the bus</a></li> </ul> <p>Changed effective minimum exposure time of Guppy PRO F-201 from 45 <math>\mu</math>s to 55 <math>\mu</math>s:</p> <ul style="list-style-type: none"> <li>• <a href="#">Guppy PRO F-201B, F-201C</a></li> <li>• <a href="#">Minimum exposure time</a></li> <li>• <a href="#">End of exposure to first packet on the bus</a></li> </ul> <p>Some minor corrections:</p> <ul style="list-style-type: none"> <li>• Guppy PRO cameras have 1 input / 3 outputs (not 2/4) in <a href="#">Pulse-width modulation</a> on page 91</li> <li>• Corrected frame rates of Guppy PRO F-031 (121 fps), F-032 (82 fps) and F-146 (17 fps) in <a href="#">Example 1: IEEE1394b bandwidth of Guppy PRO cameras</a> on page 48</li> <li>• Guppy PRO F-201B, Format_2, Mode_5: also 7.5 fps possible: see <a href="#">Guppy PRO F-201B, F-201C</a> on page 171</li> </ul>
to be continued on next page		

Table 1: Document history (continued)

Version	Date	Remarks
[continued] V3.0.2	[continued] 2012-May-18	<p>New sensors Sony ICX414 and ICX415:</p> <ul style="list-style-type: none"> <li>• Guppy PRO F-033 (Sony ICX414): <ul style="list-style-type: none"> <li>– <a href="#">Guppy PRO F-033B, F-033C</a></li> <li>– <a href="#">Figure 9: Guppy PRO F-033B, F-033C (Sony ICX414) absolute QE</a> on page 64</li> <li>– New: <a href="#">Table 17: Guppy PRO F-033, F-046, F-146 focal length vs. field of view</a> on page 77</li> <li>– <a href="#">Video fixed formats Guppy PRO F-033B, F-033C</a></li> <li>– <a href="#">Video Format_7 default modes Guppy PRO F-033B, F-033C</a></li> <li>– <a href="#">Guppy PRO F-033: AOI frame rates</a></li> </ul> </li> <li>• Guppy PRO F-046 (Sony ICX415): <ul style="list-style-type: none"> <li>– <a href="#">Guppy PRO F-046B, F-046C</a></li> <li>– <a href="#">Figure 11: Guppy PRO F-046B, F-046C (Sony ICX415) absolute QE</a> on page 65</li> <li>– New: <a href="#">Table 17: Guppy PRO F-033, F-046, F-146 focal length vs. field of view</a> on page 77</li> <li>– <a href="#">Video fixed formats Guppy PRO F-046B, F-046C</a></li> <li>– <a href="#">Video Format_7 default modes Guppy PRO F-046B, F-046C</a></li> <li>– <a href="#">Guppy PRO F-046: AOI frame rates</a></li> </ul> </li> </ul> <p>Guppy PRO F-503:</p> <ul style="list-style-type: none"> <li>• F0M2 (120 fps), F0M5 (120 fps), F1M5 (60 fps) are only available with electronic rolling shutter (whereas present in both shutter modes). If using global reset release shutter the camera runs these modes with half frame rates only. See <a href="#">Guppy PRO F-503B, F-503C</a> on page 173.</li> <li>• Changed range in dB and increment length: <a href="#">Table 48 : Manual gain range for Guppy PRO models</a> on page 108</li> </ul> <p>IR cut filter:</p> <ul style="list-style-type: none"> <li>• Changed IR cut filter to (type Jenofilt 217): see <a href="#">Figure 24: Typical spectral transmission of IR cut filter type Hoya C5000</a> (values may vary slightly by filter lot) on page 75</li> </ul>

Table 1: Document history (continued)

Version	Date	Remarks
V3.0.3	2012-Jun-14	<p>New frame rates from development:</p> <p>Guppy PRO F-031</p> <ul style="list-style-type: none"> <li>• 123 fps instead of 121 fps in F7M0, see <a href="#">Figure 5: Guppy PRO F-031B, F-031C (Sony ICX618) absolute QE</a> on page 62</li> <li>• 564 fps instead of 563 fps (AOI height 10, Raw12), see <a href="#">Table 91: Frame rates as function of AOI height [width=656]</a> on page 183</li> <li>• 188 fps instead of 199 fps (F7M2, Mono16), see <a href="#">Table 72: Video Format_7 default modes Guppy PRO F-031B, F-031C</a> on page 160</li> </ul> <p>Guppy PRO F-032</p> <ul style="list-style-type: none"> <li>• F7M0 (Raw8/Raw12/Raw16/YUV411/YUV422/Mono8/Mono12/Mono16): 82 fps instead of 79 fps, see <a href="#">Table 74: Video Format_7 default modes Guppy PRO F-032B, F-032C</a> on page 162</li> </ul> <p>Guppy PRO F-033</p> <ul style="list-style-type: none"> <li>• F7M0 (RGB8): 85 fps instead of 84 fps. F7M0 (RGB8): 67 fps instead of 66 fps. See <a href="#">Table 76: Video Format_7 default modes Guppy PRO F-033B, F-033C</a> on page 164</li> <li>• 85 fps instead of 84 fps. See <a href="#">Guppy PRO F-033B, F-033C</a> on page 55</li> </ul> <p>Guppy PRO F-046</p> <ul style="list-style-type: none"> <li>• 62 fps instead of 61 fps. See <a href="#">Guppy PRO F-046B, F-046C</a> on page 56</li> <li>• F7M0 (Raw8/Raw12/Raw16/YUV411/YUV422/Mono8): 62 fps instead of 61 fps, see <a href="#">Table 78: Video Format_7 default modes Guppy PRO F-046B, F-046C</a> on page 166</li> </ul> <p>Guppy PRO F-125</p> <ul style="list-style-type: none"> <li>• 31 fps instead of 30 fps. See <a href="#">Guppy PRO F-125B, F-125C</a> on page 57</li> </ul> <p>Guppy PRO F-146</p> <ul style="list-style-type: none"> <li>• F7M0 (RGB8): 15 fps instead of 17 fps, see <a href="#">Table 82: Video Format_7 default modes Guppy PRO F-146B, F-146C</a> on page 170</li> </ul> <p>Guppy PRO F-201</p> <ul style="list-style-type: none"> <li>• F7M0 (RGB8): 12 fps instead of 10 fps, see <a href="#">Table 84: Video Format_7 default modes Guppy PRO F-201B, F-201C</a> on page 172</li> <li>• F7M0 (RGB8): 12 fps instead of 10 fps, see <a href="#">Table 97: Frame rates of as function of AOI height [width=1624]</a> on page 189</li> </ul>

Table 1: Document history (continued)

Version	Date	Remarks
V4.0.0	2012-Jul-23	<p>Deleted Active FirePackage in <a href="#">Specifications</a> on page 52</p> <p>New Guppy PRO F-125</p> <ul style="list-style-type: none"> <li>• <a href="#">Table 4: Bandwidth of Guppy PRO models</a> on page 48</li> <li>• <a href="#">Guppy PRO F-125B, F-125C</a></li> <li>• <a href="#">Exposure time offset</a></li> <li>• <a href="#">Minimum exposure time</a></li> <li>• <a href="#">Jitter at exposure start (no binning, no sub-sampling)</a></li> <li>• <a href="#">End of exposure to first packet on the bus</a></li> <li>• <a href="#">Guppy PRO F-125B, F-125C</a></li> <li>• <a href="#">Power consumption: typically &lt; 3.5 W, see <a href="#">Guppy PRO F-125B, F-125C</a> on page 57</a></li> </ul> <p>Deleted Active FirePackage in <a href="#">Specifications</a> on page 52</p> <p>New Guppy PRO F-125</p> <ul style="list-style-type: none"> <li>• <a href="#">Table 4: Bandwidth of Guppy PRO models</a> on page 48</li> <li>• <a href="#">Guppy PRO F-125B, F-125C</a></li> <li>• <a href="#">Exposure time offset</a></li> <li>• <a href="#">Minimum exposure time</a></li> <li>• <a href="#">Jitter at exposure start (no binning, no sub-sampling)</a></li> <li>• <a href="#">End of exposure to first packet on the bus</a></li> <li>• <a href="#">Guppy PRO F-125B, F-125C</a></li> <li>• <a href="#">Power consumption: typically &lt; 3.5 W, see <a href="#">Guppy PRO F-125B, F-125C</a> on page 57</a></li> </ul>

Table 1: Document history (continued)

Version	Date	Remarks
V4.0.1	2012-Sep-12	<ul style="list-style-type: none"> <li>• Checked terminology throughout the Technical Manual</li> <li>• Changed frame rates for Guppy PRO F-201: see <a href="#">Guppy PRO F-201: AOI frame rates</a> on page 189</li> <li>• For Guppy PRO F-201B/C: Added fixed frame rate 15 fps, see <a href="#">Guppy PRO F-201B, F-201C</a> on page 59</li> <li>• Changed with zero overshoot to to with minimum overshoot: see <a href="#">Auto shutter</a> on page 104</li> <li>• For Guppy PRO F-146 changed Exposure time offset from 35 <math>\mu</math>s to 31 <math>\mu</math>s, see <a href="#">Exposure time offset</a> on page 149 and <a href="#">Minimum exposure time</a> on page 150 and <a href="#">Figure 69: Data flow and timing after end of exposure</a> on page 154 and <a href="#">Guppy PRO F-146B, F-146C</a> on page 58 (shutter speed changed from 46 <math>\mu</math>s to 41 <math>\mu</math>s)</li> <li>• Guppy PRO F-031B: new measurement changed QE diagram (with 57% at 530 nm), see <a href="#">Figure 5: Guppy PRO F-031B, F-031C (Sony ICX618) absolute QE</a> on page 62</li> <li>• Guppy PRO F-146, Frame rates: Note: 30 fps only for color cameras, see <a href="#">Guppy PRO F-146B, F-146C</a> on page 58</li> <li>• Guppy PRO F-031B: F7M2, Mono16, 199 fps (instead of 188 fps), <a href="#">Video Format_7 default modes Guppy PRO F-031B, F-031C</a> on page 160</li> <li>• Updated RoHS directive</li> <li>• Updated figures throughout the manual</li> </ul>

Table 1: Document history (continued)

Version	Date	Remarks
V4.1.0	2015-Mar-09	<p>Updated data:</p> <ul style="list-style-type: none"> <li>• Corrected hyperlinks to targets on the Allied Vision website</li> <li>• Removed outdated information in <a href="#">Requirements for PC and IEEE1394b</a> on page 48</li> <li>• Added hyperlink to FireWire accessories on the Allied Vision website in <a href="#">Requirements for PC and IEEE1394b</a> on page 48</li> <li>• Removed information on the Universal Package in <a href="#">Operating system support</a> on page 51</li> <li>• Reduced to the current information on the system requirements in <a href="#">Operating system support</a> on page 51</li> <li>• Added information that all color modes in <a href="#">Specifications</a> on page 52 comply with the IIDC specifications</li> <li>• Corrected information in <a href="#">Sensor position accuracy of Guppy PRO cameras</a> on page 257</li> <li>• Adapted addresses in <a href="#">Contact us</a> on page 15</li> <li>• Corrected information for binning in Definition on page 116</li> <li>• Corrected block diagram for Guppy PRO color cameras in <a href="#">Block diagrams of Guppy PRO models</a> on page 98</li> <li>• Updated sensor curves in <a href="#">Spectral sensitivity</a> on page 61</li> <li>• Added information on CS-Mount in <a href="#">Maximum protrusion: CS-Mount</a> on page 73</li> </ul> <p>Layout changes due to a changed Corporate identity:</p> <ul style="list-style-type: none"> <li>• Replaced the previous Allied Vision logo by the current one</li> <li>• Reworded all appropriate contents from AVT and Allied Vision Technologies to Allied Vision</li> </ul>
V4.1.1	2017-Mar-18	<p>Updated data:</p> <ul style="list-style-type: none"> <li>• Corrected pin count for Hirose connector for specifications in <a href="#">Guppy PRO F-503B, F-503C</a> on page 60</li> <li>• Added a note about Hirose I/O connectors in <a href="#">Camera I/O connections</a> on page 80</li> <li>• Updated note about accuracy of measurements for quantum efficiency in <a href="#">Specifications</a> on page 52.</li> <li>• Deleted contents related to discontinued Guppy PRO-095C.</li> <li>• Updated the absolute QE plots for all models and added spectral response plots for select models</li> </ul>
V4.1.2	2017-Apr-07	Added cable color to camera I/O connector pin assignment including pin assignment figure and cross reference to the Allied Vision I/O cable data sheet
V4.1.3	2018-Jan-05	Applied minor changes.

Table 1: Document history (continued)

Version	Date	Remarks
V4.1.4	2019-Jan-02	<ul style="list-style-type: none"> <li>Added contents for camera EMC compliance in <a href="#">Camera I/O connections</a> on page 80.</li> <li>Applied minor changes.</li> <li>Corrected typos.</li> </ul>
V4.1.5	2019-Feb-27	Applied editorial changes.
V4.1.6	2019-Jul-10	Applied editorial changes.
V4.1.7	2020-May-25	<ul style="list-style-type: none"> <li>Updated data in <a href="#">Compliance, safety, and intended use</a> on page 37 and in <a href="#">Intended use</a> on page 38.</li> <li>Added data in <a href="#">Read before use</a> on page 2, <a href="#">Your safety</a> on page 39, <a href="#">Avoiding material damage</a> on page 40, and <a href="#">Warranty note</a> on page 41.</li> <li>Updated spectral plots.</li> <li>Applied minor editorial changes.</li> </ul>
V4.1.8	2021-Jul-13	Applied editorial changes.
V4.1.9	2021-Aug-19	<ul style="list-style-type: none"> <li>Added icon for compliance with UKCA in <a href="#">Compliance notifications</a> on page 37.</li> <li>Applied minor editorial changes.</li> </ul>
V4.2.0	2022-Aug-19	<ul style="list-style-type: none"> <li>Renamed from Technical Manual to User Guide.</li> <li>Added Hebrew contents to <a href="#">Read before use</a> on page 2.</li> </ul>
V4.2.1	2023-Jan-27	<ul style="list-style-type: none"> <li>Added note that lenses are not part of the product.</li> <li>Updated Hebrew contents in <a href="#">Read before use</a> on page 2.</li> </ul>
V4.2.2	2023-Jul-10	Applied editorial changes.
V4.2.3	2023-Dec-19	Maximum protrusion for Guppy PRO lens mounts was temporarily higher than stated in this document. Therefore, notes were added to <a href="#">Maximum protrusion: C-Mount</a> on page 72 and <a href="#">Maximum protrusion: CS-Mount</a> on page 73, and the technical drawing for CS-Mount was updated.

Table 1: Document history (continued)

## Manual overview

This manual overview describes each chapter of this manual shortly.

- [Contact us](#) on page 15 lists Allied Vision contact information for both:
  - technical information / ordering
  - commercial information
- [Introduction](#) (this chapter) gives you the document history, a manual overview and conventions used in this manual (styles and symbols). Furthermore, you learn how to get more information on how to install hardware (*1394 Installation Manual*), available Allied Vision software (including documentation) and where to get it.

- [Guppy PRO cameras](#) provides a short introduction to the Guppy PRO cameras with their FireWire technology. Links are provided to data sheets and brochures on Allied Vision website.
- [Compliance, safety, and intended use](#) gives you information about conformity and intended use of Allied Vision cameras.
- [FireWire](#) describes the FireWire standard in detail, explains the compatibility between IEEE1394a and IEEE1394b and explains bandwidth details (including Guppy PRO examples).
  - Read and follow the FireWire hot-plug and screw-lock precautions in [FireWire hot-plug and screw-lock precautions](#) on page 50.
  - Read [Operating system support](#) on page 51.
- [Filter and lenses](#) describes the IR cut filter and suitable camera lenses.
- [Specifications](#) lists camera details and absolute QE diagrams for each camera type.
- [Camera dimensions](#) provides CAD drawings of standard housing (copper and GOF) models, tripod adapter, available angled head models, cross sections of CS-Mount and C-Mount.
- [Camera interfaces](#) describes in detail the inputs/outputs of the cameras (including trigger features). For a general description of the interfaces (FireWire and I/O connector) see *1394 Installation Manual*.
- [Description of the data path](#) describes in detail IIDC conform as well as Allied Vision specific camera features.
- [Controlling image capture](#) describes trigger modes, exposure time, one-shot/multi-shot/ISO Enable features.
- [Video formats, modes and bandwidth](#) lists all available fixed and Format\_7 modes (including color modes, frame rates, binning/sub-sampling, AOI = area of interest).
- [How does bandwidth affect the frame rate?](#) gives some considerations on bandwidth details.
- [Configuration of the camera](#) lists standard and advanced register descriptions of all camera features.
- [Firmware update](#) explains where to get information on firmware updates and explains the extended version number scheme of FPGA/micro controller.
- [Appendix](#) lists the sensor position accuracy of Allied Vision cameras.
- [Index](#) gives you quick access to all relevant data in this manual.



## Conventions used in this manual

To give this manual an easily understood layout and to emphasize important information, the following typographical styles and symbols are used.

### Styles

Style	Function	Example
Bold	Programs, inputs or highlighting important things	<b>bold</b>
Courier	Code listings etc.	Input
Upper case	Register	REGISTER
Italics	Modes, fields	<i>Mode</i>
Parentheses and/or blue	Links	<a href="#">(Link)</a>

Table 2: Styles

### Symbols and notes



#### CAUTION

##### **Risk of burns**

Precautions are described



#### CAUTION

##### **Injury by falling cameras or lenses**

Precautions are described



#### CAUTION

##### **Risk of cuts by sharp edges of lens mounts**

Precautions are described

**Note** This symbol highlights important information.



**Caution**

This symbol highlights important instructions. You have to follow these instructions to avoid malfunctions.

**www**

This symbol highlights URLs for further information. The URL itself is shown in blue.



Example:

[www.alliedvision.com](http://www.alliedvision.com)

## More information

For more information on hardware and software read the following:

*1394 Installation Manual* describes the hardware installation procedures for all IEEE1394 cameras (Marlin, Guppy, Pike, Stingray). Additionally, you get safety instructions and information about camera interfaces (IEEE1394a, IEEE1394b copper and GOF, I/O connectors, input and output).

**www**

You find the *1394 Installation Manual* here:

[twww.alliedvision.com/en/support/technical-documentation](http://twww.alliedvision.com/en/support/technical-documentation)

**www**

All software packages (including documentation and release notes) provided by Allied Vision can be downloaded at:

[www.alliedvision.com/en/support/software-downloads](http://www.alliedvision.com/en/support/software-downloads)



## Before operation

We place the highest demands for quality on our cameras.

**Target group** This Technical Manual is the guide to detailed technical information of the camera and is written for experts.

**Getting started** For a quick guide how to get started read *1394 Installation Manual* first.

**Note**

Please read through this manual carefully before operating the camera.



For information on Allied Vision accessories and software read *1394 Installation Manual*.

**Caution**

Before operating any Allied Vision camera read safety instructions and ESD warnings in *1394 Installation Manual*.

**Note**

To demonstrate the properties of the camera, all examples in this manual are based on the FirePackage OHCI API software and the SmartView application.

**Note**

The camera also works with all IIDC (formerly DCAM) compatible IEEE1394 programs and image processing libraries.



All naming in this document relates to FirePackage, not to GenICam.

**www**

For downloads see:



Software (Vimba and all other software):

[www.alliedvision.com/en/support/software-downloads](http://www.alliedvision.com/en/support/software-downloads)

Firmware:

[www.alliedvision.com/en/support/firmware-downloads](http://www.alliedvision.com/en/support/firmware-downloads)

Technical documentation (overview page):

[www.alliedvision.com/en/support/technical-documentation](http://www.alliedvision.com/en/support/technical-documentation)

Application notes:

[www.alliedvision.com/en/support/faqs-application-notes](http://www.alliedvision.com/en/support/faqs-application-notes)

## Guppy PRO cameras

- Guppy PRO** Guppy PRO cameras have made entry into the world of digital image processing simpler and more cost-effective. Guppy PRO cameras are the smallest IEEE1394b cameras worldwide.
- IEEE1394b** With the Guppy PRO, Allied Vision presents a wide range of cameras with IEEE1394b interfaces.
- Image applications** Allied Vision provides users with a range of products that meet almost all the requirements of a very wide range of image applications.
- FireWire** The industry standard IEEE1394 (FireWire) facilitates the simplest computer compatibility and bidirectional data transfer. Further development of the IEEE1394 standard has already made 800 Mbit/s possible. Investment in this standard is, therefore, secure for the future; each further development takes into account compatibility with the preceding standard, and vice versa, meaning that IEEE1394b is backward-compatible with IEEE1394a. Your applications will grow as technical progress advances.

**Note**

For further information on FireWire read Chapter [FireWire](#) on page 42.

**Note**

All naming in this document relates to FirePackage, not to GenICam.

**www**

For further information on the highlights of Guppy PRO models, the Guppy PRO family, and the whole range of Allied Vision FireWire cameras read the data sheets and brochures on our website:



[www.alliedvision.com/en/support/technical-documentation/guppy-pro-documentation](http://www.alliedvision.com/en/support/technical-documentation/guppy-pro-documentation)

# Compliance, safety, and intended use

## Compliance notifications

For customers in China and Europe



National regulations on disposal must be followed.

For customers in the USA

### **FCC Class B digital device**

This equipment has been tested and found to comply with the limits for a Class B digital device, pursuant to part 15 of the FCC Rules. These limits are designed to provide reasonable protection against harmful interference in a residential installation. This equipment generates, uses and can radiate radio frequency energy and, if not installed and used in accordance with the instructions, may cause harmful interference to radio communications. However, there is no guarantee that interference will not occur in a particular installation. If this equipment does cause harmful interference to radio or television reception, which can be determined by turning the equipment off and on, the user is encouraged to try to correct the interference by one or more of the following measures:

- Reorient or relocate the receiving antenna.
- Increase the separation between the equipment and receiver.
- Connect the equipment into an outlet on a circuit different from that to which the receiver is connected.
- Consult the dealer or an experienced radio/TV technician for help.

### **United States of America: Supplier Declaration of Conformity**

Guppy PRO cameras comply with Part 15 of the FCC Rules. Operation is subject to the following two conditions:

1. This device may not cause harmful interference, and
2. this device must accept any interference received, including interference that may cause undesired operation.

### **Party issuing Supplier's Declaration of Conformity**

Allied Vision Technologies GmbH  
Taschenweg 2a  
07646 Stadtroda  
Germany  
T// +49 (36428) 677-106  
quality@alliedvision.com

**Responsible Party - U.S. Contact Information**

Allied Vision Technologies, Inc.  
102 Pickering Way – Suite 502  
Exton, PA 19341  
USA  
T// +1 978 225 2030

**Note:** changes or modifications not expressly approved by the party responsible for compliance could void the user's authority to operate the equipment.

**For customers in Canada**

This apparatus complies with the Class B limits for radio noise emissions set out in the Radio Interference Regulations.

CAN ICES-3 (B) / NMB-3 (B)

**Pour utilisateurs au Canada**

Cet appareil est conforme aux normes classe B pour bruits radioélectriques, spécifiées dans le Règlement sur le brouillage radioélectrique.

CAN ICES-3 (B) / NMB-3 (B)

**Avoid electromagnetic interferences**

For all power and interface connections, only use shielded cables or cables recommended by Allied Vision.

## Intended use

Allied Vision's objective is the development, design, production, maintenance, servicing and distribution of digital cameras and components for image processing. We are offering standard products as well as customized solutions. Intended use of Allied Vision product is the integration into Vision systems by professionals. All Allied Vision product is sold in a B2B setting.

Allied Vision isn't a legal manufacturer of medical product. Instead, Allied Vision cameras and accessories may be used as components for medical product after design-in by the medical device manufacturer and based on a quality assurance agreement (QAA) between Allied Vision (supplier) and medical device manufacturer (customer). Allied Vision's duties in that respect are defined by ISO 13485, clause 7.2 (customer-related processes, equivalent to ISO 9001, clause 8.2).

## Copyright and trademarks

All text, pictures, and graphics are protected by copyright and other laws protecting intellectual property. All content is subject to change without notice.

All trademarks, logos, and brands cited in this document are property and/or copyright material of their respective owners. Use of these trademarks, logos, and brands does not imply endorsement.

Copyright © 2023 Allied Vision Technologies GmbH. All rights reserved.

## Your safety

This section informs about issues related to your personal safety. Descriptions explain how to avoid hazards and operate Guppy PRO cameras safely.

### Handling lens mounts

The lens mount thread has sharp edges. Be careful these edges do not cut your skin when mounting or unmounting lenses.

### Handling hot cameras

If you hold the camera in your hands during operation, your skin may get hurt. If you touch the camera when it is heated up, we recommend wearing protective gloves.

### Providing optimum heat dissipation

Keep the operating temperature in the specified range to enable best image quality and to protect the camera from damage. Temperature values apply to a relative humidity of 0 to 80 percent that is non-condensing.

For your safety and to improve camera performance, operate the camera:

- Mounted to a base with a high thermal conductivity
- With lens or other optical components mounted
- With a heat sink mounted that has large surface areas (closed housing cameras include a heat sink)
- Using conductive media for camera and heat sink mounting
- With active cooling of camera, mounting base, and heat sink, such as by ventilation

### Camera mounting

Cameras must be mounted using the mounting threads. If vibration is very high, cameras can disconnect from the mounting. Falling cameras can hurt you.

For heavy or long lenses, we recommend you to use a lens support and apply additional tests.

## Avoiding material damage

### Electronics maintenance

There are no switches or parts inside the camera housing that require adjustment. The warranty becomes void upon opening the camera casing.

### Cable connections

#### Powering cameras

Operating the camera beyond the specified range damages the camera.

The camera does not generate dangerous voltages internally. However, because the IEEE 1394 standard permits cable power distribution at voltages higher than 24 V DC, various international safety standards apply.

Cameras can be powered using the I/O connector at an input range of 8 to 36 VDC, using a limited power source (LPS), according to IEC 62368-1 with minimum 2 A. The camera is not intended to be connected to a DC distribution network. The maximum length for I/O cables must not exceed 30 meters.

Only use power supplies that meet the insulation requirement according to PELV or SELV. For details, please refer to IEC 61140.

If using external power supplies by third-party manufacturers, observe polarity to avoid damage to the camera electronics.

If you feel uncomfortable with the following advice or if you have no knowledge about the connectivity of an installation, we strongly recommend powering down all systems before connecting or disconnecting a camera.

#### No hot plugging

Although FireWire devices can theoretically be hot-plugged without powering down equipment, we strongly recommend turning the computer power off before connecting a digital camera to it via a FireWire cable.

Static electricity or slight plug misalignment during insertion may short-circuit and damage components.

#### Avoiding electrostatic discharge (ESD)

The physical ports may be damaged by excessive ESD when connected under powered conditions. It is good practice to ensure proper grounding of computer case and camera case to the same ground potential before plugging the camera cable into the port of the computer. This ensures that no excessive difference of electrical potential exists between computer and camera.

Make sure not to touch the shield of the camera cable connected to a computer and the ground terminal of the lines at the same time. If you are charged: before touching the shield of the camera cable, make sure to discharge first (by touching the ground terminal of the lines).



**Maximum inrush current**

It is very important not to exceed an inrush current of 18 mJoule in 3 ms. (This means that a device, when powered via 12 VDC bus power, must never draw more than 1.5 A, even not in the first 3 ms.)

Higher inrush current may damage the physical interface chip of the camera and/or the phy chip in your PC.

Whereas inrush current is not a problem for a single 1394b camera, daisy chaining multiple cameras or supplying bus power via (optional) HIROSE power out to circuitry with unknown inrush currents needs careful design considerations to be on the safe side.

**Suitable accessories**

All Allied Vision 1394b camera and cables have industrial screw-lock fasteners to insure a tight electrical connection that is resistant to vibration and gravity.

We strongly recommend using only 1394b adapter cards with screw-locks.

Use only DC power supplies with insulated cases. These are identified by having only two power connectors.

**Cleaning cameras**

Mount/remove lenses and filters in a dust-free environment. Use only quality optical tissue/cloth if you must clean a lens or filter. Read the 1394 Installation Manual, Chapter Cleaning instructions.

## Warranty note

If the product is disassembled, reworked, repaired or cleaned by unauthorized service personnel, Allied Vision or its suppliers cannot be held liable for any subsequent performance decrease of the camera or quality decrease of the camera output.

# FireWire

## Overview

FireWire provides one of the most comprehensive, high-performance, and cost-effective solutions platforms. FireWire offers very impressive throughput at very affordable prices.

### Definition

FireWire (also known as i.Link or IEEE1394) is a personal computer and digital video serial bus interface standard, offering high-speed communications and isochronous real-time data services. FireWire has low implementation costs and a simplified and adaptable cabling system.



*Figure 1: FireWire Logo*

### IEEE1394 standards

FireWire was developed by Apple in the late 1990s, after work defining a slower version of the interface by the IEEE1394 working committee in the 1980s. Apple's development was completed in 1995. It is defined in IEEE standard 1394, which is currently a composite of three documents:

- Original IEEE Std. 1394-1995
- IEEE Std. 1394a-2000 amendment
- IEEE Std. 1394b-2002 amendment

FireWire is used to connect digital cameras, especially in industrial systems for machine vision.

#### **Note**

All naming in this document relates to FirePackage, not to GenICam.



## Why use FireWire?

Digital cameras with on-board FireWire (IEEE1394a or IEEE1394b) communications conforming to the IIDC standard (V1.3 or V1.31) have created cost-effective and powerful solutions options being used for thousands of different applications around the world. FireWire is currently the premier robust digital interface for industrial applications for many reasons, including:

- Guaranteed bandwidth features to ensure fail-safe communications
- Interoperability with multiple different camera types and vendors
- Diverse camera powering options, including single-cable solutions up to 45 W
- Effective multiple-camera solutions
- Large variety of FireWire accessories for industrial applications
- Availability of repeaters and optical fiber cabling
- Forward and backward compatibility blending IEEE1394a and IEEE1394b
- Both real-time (isochronous) and demand-driven asynchronous data transmission capabilities

## FireWire in detail

### Serial bus

FireWire is a very effective way to utilize a low-cost serial bus, through a standardized communications protocol, that establishes packetized data transfer between two or more devices. FireWire offers real time isochronous bandwidth for image transfer with guaranteed low latency. It also offers asynchronous data transfer for controlling camera parameters on the fly, such as gain and shutter. As illustrated in the diagram below, these two modes can co-exist by using priority time slots for video data transfer and the remaining time slots for control data transfer.

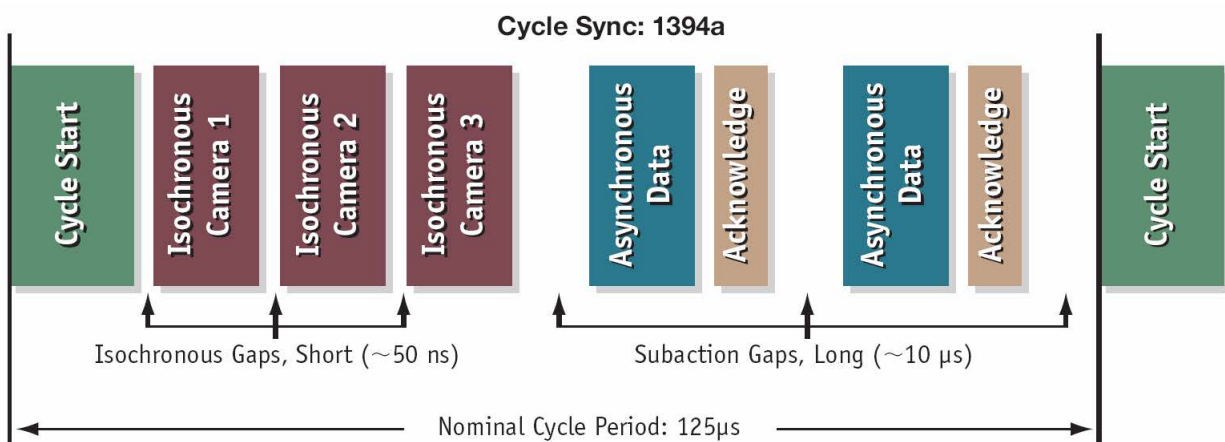

Figure 2: IEEE1394a data transmission

Whereas IEEE1394a works in half duplex transmission, IEEE1394b does full duplex transmission. IEEE1394b optimizes the usage of the bandwidth, as it does not need gaps between the signals like IEEE1394a. This is due to parallel arbitration, handled by the bus owner supervisor selector (BOSS). For details see the following diagram:

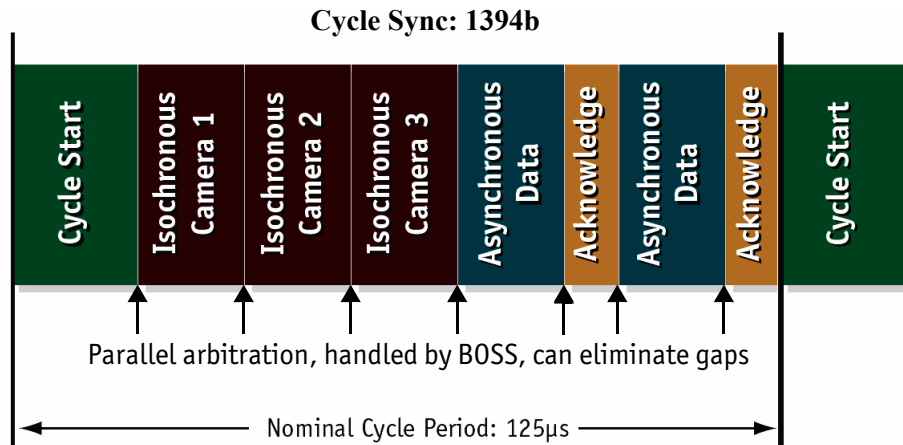

Figure 3: IEEE1394b data transmission

Additional devices may be added up to the overall capacity of the bus, but throughput at guaranteed minimum service levels is maintained for all devices with an acknowledged claim on the bus. This deterministic feature is a huge advantage for many industrial applications where robust performance is required. This applies with applications that do not allow dropping images within a specific time interval.

### FireWire connection capabilities

FireWire can connect together up to 63 peripherals in an acyclic network structure (hubs). It allows peer-to-peer device communication between digital cameras, without using system memory or the CPU.

A FireWire camera can directly, via direct memory access (DMA), write into or read from the memory of the computer with almost no CPU load.

FireWire also supports multiple hosts per bus. FireWire requires only a cable with the correct number of pins on either end (normally 6 or 9).

#### **Caution**



While supplying such an amount of bus power is clearly a beneficial feature, it is very important not to exceed the inrush current of 18 mJoule in 3 ms.

Higher inrush current may damage the PHY chip of the camera and/or the PHY chip in your PC.

## Capabilities of IEEE1394a (FireWire 400)

FireWire 400 (S400) is able to transfer data between devices at 100, 200, or 400 MBit/s data rates.

The IEEE1394a capabilities in detail:

- 400 Mbit/s
- Hot-pluggable devices
- Peer-to-peer communications
- Direct Memory Access (DMA) to host memory
- Guaranteed bandwidth
- Multiple devices (up to 45 W) powered via FireWire bus

### IIDC V1.3 camera control standards

IIDC V1.3 released a set of camera control standards via IEEE1394a, which established a common communications protocol on which most current FireWire cameras are based.

In addition to common standards shared across manufacturers, Allied Vision offers Format\_7 mode that provides special features (smart features), such as:

- Higher resolutions
- Higher frame rates
- Diverse color modes

as extensions (advanced registers) to the prescribed common set.

## Capabilities of IEEE1394b (FireWire 800)

FireWire 800 (S800) was introduced commercially by Apple in 2003 and has a 9-pin FireWire 800 connector (see the *1394 Installation Manual* and in chapter [IEEE1394b port pin assignment](#) on page 79 for details). This newer IEEE1394b specification allows a transfer rate of 800 MBit/s with backward compatibility to the slower rates and 6-pin connectors of FireWire 400.

The IEEE1394b capabilities in detail:

- 800 Mbit/s
- All previously described benefits of IEEE1394a
- Interoperability with IEEE1394a devices
- Longer communications distances (up to 500 m using GOF cables)

### IIDC V1.31 camera control standards

Along with IEEE1394b, the IIDC V1.31 standard arrived in January 2004, evolving the industry standards for digital imaging communications to include I/O and RS232 handling, and adding further formats. The increased bandwidths enable transmitting high-resolution images to the PC's memory at high frame rates.

## Compatibility between IEEE1394a and IEEE1394b



 <p><b>1394b port</b></p> <p><b>1394a camera</b></p> <p>IEEE1394a camera connected to IEEE1394b bus</p> <p>The cable explains dual compatibility: This cable serves to connect an IEEE1394a camera with its six-pin connector to a bilingual port (a port which can talk in a- or b-language) of a IEEE1394b bus.</p> <p>In this case, the b-bus communicates in a-language and a-speed with the camera achieving a-performance</p>	 <p><b>1394b camera</b></p> <p><b>1394a port</b></p> <p>IEEE1394b camera connected to IEEE1394a bus</p> <p>The cable explains dual compatibility: In this case, the cable connects an IEEE1394b camera with its nine-pin connector to a IEEE1394a port.</p> <p>In this case, the b-camera communicates in a-language with the camera achieving a-performance</p>
--	--

Figure 4: IEEE1394a and IEEE1394b cameras and compatibility

### Compatibility example

It is possible to run a IEEE1394a and a IEEE1394b camera on the IEEE1394b bus.

You can e.g. run a Guppy PRO F-032B and a Marlin F-033B on the same bus:

- Guppy PRO F-032B @ S800 and 60 fps (2560 bytes per cycle, 32% of the cycle slot)
- Marlin F-033B @ S400 and 30 fps (1280 bytes, 32% of the cycle slot)

Bus runs at 800 Mbit/s for all devices. Data from Marlin's port is up-converted from 400 Mbit/s to 800 Mbit/s by data doubling (padding), still needing 32% of the cycle slot time. This doubles the bandwidth requirement for this port, as if the camera runs at 60 fps. Total consumption is thus  $2560 + 2560 = 5120$  bytes per cycle.

## Image transfer via IEEE1394a and IEEE1394b

Technical detail	IEEE1394a	IEEE1394b
Transmission mode	Half duplex (both pairs needed) 400 Mbit/s data rate  aka: a-mode, data/strobe (D/S) mode, legacy mode	Full duplex (one pair needed) 1 Gbit/s signaling rate, 800 Mbit/s data rate  10b/8b coding (Ethernet), aka: b-mode (beta mode)
Devices	Up to 63 devices per network	
Number of cameras	Up to 16 cameras per network	
Number of DMAs	4 to 8 DMAs (parallel) cameras / bus	
Real time capability	Image has real time priority	
Available bandwidth acc. IIDC (per cycle 125 $\mu$ s)	4096 bytes per cycle ~ 1000 quadlets @ 400 Mbit/s	8192 bytes per cycle ~ 2000 quadlets @ 800 Mbit/s (@1 GHz clock rate)
	For further detail read chapter <a href="#">Frame rates</a> on page 178.	
Max. image bandwidth	31.25 MByte/s	62.5 MByte/s
Max. total bandwidth	~45 MByte/s	~85 MByte/s
Number of busses	Multiple busses per PC limit: PCI bus	Multiple busses per PC limit: PCI (Express) bus
CPU load	Almost none for DMA image transfer	
Gaps	Gaps negatively affect asynchronous performance of widespread network (round trip delay), reducing efficiency	No gaps needed, BOSS mode for parallel arbitration

Table 3: Technical detail comparison: IEEE1394a and IEEE1394b

### Note

The bandwidth values refer to the fact:

1 MByte = 1024 KB



### IEEE1394b bandwidths

According to the IEEE1394b specification on isochronous transfer, the largest recommended data payload size is 8192 bytes per 125  $\mu$ s cycle at a bandwidth of 800 Mbit/s.

**Note** Certain cameras may offer, depending on their settings in combination with the use of FirePackage higher packet sizes.

 Consult your local dealer's support team, if you require additional information on this feature.

**Note** How to extend the size of an isochronous packet up to 11.000 byte at S800:



- See register 0xF1000048, ADV\_INQ\_3, Max IsoSize [1] in [Table 124: Advanced register: Advanced feature inquiry](#) on page 229
- See chapter [Maximum ISO packet size](#) on page 246

For further details read chapter [How does bandwidth affect the frame rate?](#) on page 192.

#### Requirements for PC and IEEE1394b

**Note** For FireWire accessories see:  
[www.alliedvision.com/en/support/accessory-documentation](http://www.alliedvision.com/en/support/accessory-documentation)



**Caution** As mentioned earlier, it is very important not to exceed an inrush energy of 18 mWs in 3 ms. (This means that a device, when powered via 12 V bus power, must never draw more than 1.5 A, especially in the first 3 ms.)

 Higher inrush current may damage the physical interface (PHY) chip of the camera and/or the PHY chip in your PC.

For a single Guppy PRO camera inrush current may not be a problem. But daisy chaining multiple cameras or supplying bus power via (optional) Hirose power out to circuitry with unknown inrush currents needs careful design considerations.

#### Example 1: IEEE1394b bandwidth of Guppy PRO cameras

Guppy PRO model	Resolution	Frame rate	Bandwidth
Guppy PRO F-031B, F-031C	0.3 megapixels	123 fps	39 MByte/s
Guppy PRO F-032B, F-032C	0.3 megapixels	82 fps	26 MByte/s
Guppy PRO F-033B, F-033C	0.3 megapixels	84 fps	27 MByte/s
Guppy PRO F-046B, F-046C	0.45 megapixels	61 fps	28 MByte/s

Table 4: Bandwidth of Guppy PRO models



Guppy PRO model	Resolution	Frame rate	Bandwidth
Guppy PRO F-125B, F-125C	1.2 megapixels	31 fps	38 MByte/s
Guppy PRO F-146B, F-146C	1.4 megapixels	17 fps	20 MByte/s
Guppy PRO F-201B, F-201C	2.0 megapixels	14 fps	28 MByte/s
Guppy PRO F-503B, F-503C	5.0 megapixels	13 fps	65 MByte/s

Table 4: Bandwidth of Guppy PRO models (continued)

**Note**

All data are calculated using Raw8 / Mono8 color mode. Higher bit depths or color modes will double or triple bandwidth requirements.

**Example 2: More than one Guppy PRO camera at full speed**

Due to the fact that one Guppy PRO camera can, depending on its settings, saturate a 32-bit PCI bus, you are advised to use either a PCI Express card and/or multiple 64-bit PCI bus cards, if you want to use 2 or more Guppy PRO cameras simultaneously (see the following table).

Number of cameras	PC hardware required
One Guppy PRO camera at full speed	1 × 32-bit PCI bus card (85 MByte/s)
Two or more Guppy PRO cameras at full speed	PCI Express card and/or Multiple 64-bit PCI bus cards

Table 5: Required hardware for multiple camera applications

**FireWire Plug & play capabilities**

FireWire devices implement the ISO/IEC 13213 configuration ROM model for device configuration and identification, to provide plug & play capability. All FireWire devices are identified by an IEEE EUI-64 unique identifier (an extension of the 48-bit Ethernet MAC address format) in addition to well-known codes indicating the type of device and protocols it supports. For further details read chapter [Configuration of the camera](#) on page 195.

## FireWire hot-plug and screw-lock precautions

### **Caution**



#### Hot-plug precautions

- Although FireWire devices can theoretically be hot-plugged without powering down equipment, we strongly recommend turning off the computer power, before connecting a digital camera to it.
- Static electricity or slight plug misalignment during insertion may short-circuit and damage components.
- The physical ports may be damaged by excessive electrostatic discharge (ESD), when connected under powered conditions. It is good practice to ensure proper grounding of computer case and camera case to the same ground potential, before plugging the camera cable into the port of the computer. This ensures that no excessive difference of electrical potential exists between computer and camera.
- As mentioned earlier, it is very important not to exceed the inrush energy of 18 mWs in 3 ms. (This means that a device, when powered via 12 V bus power, must never draw more than 1.5 A, especially in the first 3 ms.)
- Higher inrush current may damage the physical interface chip of the camera and/or the PHY chip in your PC. For a single Guppy PRO camera inrush current may not be a problem. But daisy chaining multiple cameras or supplying bus power via (optional) Hirose power out to circuitry with unknown inrush currents needs careful design considerations.

#### Screw-lock precautions

- All Allied Vision IEEE1394b camera and cables have industrial screw-lock fasteners to insure a tight electrical connection that is resistant to vibration and gravity.
- We strongly recommend using only IEEE1394b adapter cards with screw-locks.

## Operating system support

Operating system	IEEE1394a	IEEE1394b
Linux	Full support	Full support
Apple Mac OS	Full support	Full support
Microsoft Windows XP	Full support	<p>With SP3 the default speed for IEEE1394b is S100 (100 Mbit/s). A download and registry modification is available from Microsoft to restore performance to either S400 or S800.</p> <p>Note: The Microsoft Windows IEEE1394 driver only supports IEEE1394a.</p> <p>For IEEE1394b use either the FirePackage or install the driver provided with the IEEE1394 Bus Driver Package. (Both drivers replace the Microsoft OHCI IEEE1394 driver, but the second is 100% compliant to the driver from Microsoft. This way, applications using the MS1394 driver will continue to work).</p>
Microsoft Windows Vista	Full support	<p>Microsoft Windows Vista including SP1/SP2 supports IEEE1394b only with S400.</p> <p>Note: The Microsoft Windows IEEE1394 driver only supports IEEE1394a.</p> <p>For IEEE1394b use either the FirePackage or install the driver provided with the IEEE1394 Bus Driver Package. (Both drivers replace the Microsoft OHCI IEEE1394 driver, but the second is 100% compliant to the driver from Microsoft. This way, applications using the MS1394 driver will continue to work.)</p>
Microsoft Windows 7	Full support	Full support
Microsoft Windows 8	Full support	Full support

Table 6: FireWire and operating systems

**www**



For more information see Allied Vision Software:  
[www.alliedvision.com/en/support/software-downloads](http://www.alliedvision.com/en/support/software-downloads)

## Specifications

**Note**

- For information on bit/pixel and byte/pixel for each color mode see [table 99 on page 192](#).
- Maximum protrusion means the distance from lens flange to the glass filter in the camera.

## Guppy PRO F-031B, F-031C

Feature	Specification
Sensor	Sony ICX618AL/AQA with EXview HAD microlens CCD, progressive scan Type 1/4 (4.5 mm diagonal)
Effective chip size	3.6 mm × 2.7 mm
Cell size	5.6 μm × 5.6 μm
Picture size (max.)	656 × 492 pixels (Format_7 Mode_0)
Lens mount	Adjustable C-Mount: 17.526 mm (in air); ∅ 25.4 mm (32 tpi) Maximum protrusion: 10.1 mm (see <a href="#">figure 22: on page 72</a> )
ADC	14-bit
Color modes	Guppy PRO F-031C: Raw8, Raw12, Raw16, Mono8, YUV411, YUV422, RGB8
Frame rates	1.875 fps; 3.75 fps; 7.5 fps; 15 fps; 30 fps; 60 fps; 120 fps Up to 123 fps in Format_7
Gain control	Manual: 0 to 24.4 dB (0.0359 dB/step); auto gain (select. AOI)
Shutter speed	75 μs to 67,108,864 μs (~ 67 s); auto shutter (select. AOI)
External trigger shutter	Programmable, trigger level control, single trigger, bulk trigger, programmable trigger delay
Look-up tables	User-programmable (12-bit → 10-bit); default gamma (0.45)
Smart functions	Auto gain control (AGC), auto exposure control (AEC), autofunction AOI, look-up table (LUT), 1 storable user set  Guppy PRO F-031B: Binning, sub-sampling Guppy PRO F-031C: Auto white balance (AWB), color correction, hue, saturation
I/Os	1 configurable input (optocoupled), 3 configurable outputs (optocoupled)
Transfer rate	100 Mbit/s, 200 Mbit/s, 400 Mbit/s, 800 Mbit/s
Digital interface	IEEE1394b (IiDC V1.31), 1 × copper connector
Power requirements	DC 8 V to 36 V via IEEE1394 cable or 12-pin Hirose
Power consumption	Typical < 3.5 watt @ 12 VDC (full resolution and maximum frame rate)
Dimensions (L × W × H)	44.8 x 29 x 29 mm
Mass (typical)	75 g 80 g with filter ring
Operating temperature	+ 5 °C to + 45 °C ambient temperature (non-condensing)
Storage temperature	- 10 °C to + 70 °C ambient temperature (non-condensing)
Standard accessories	Guppy PRO F-031B: Protection glass   Guppy PRO F-031C: IR cut filter
Optional accessories	Guppy PRO F-031B: IR cut filter, IR pass filter   Guppy PRO F-031C: Protection glass
On request	Host adapter card, power out 6 W (Hirose)
Software packages	<a href="http://www.alliedvision.com/en/support/software-downloads">www.alliedvision.com/en/support/software-downloads</a>

Table 7: Guppy PRO F-031B, F-031C model specifications

## Guppy PRO F-032B, F-032C

Feature	Specification
Sensor	Sony ICX424AL/AQ with HAD microlens CCD, progressive scan Type 1/3 (6 mm diagonal)
Effective chip size	4.9 mm × 3.7 mm
Cell size	7.4 μm × 7.4 μm
Picture size (max.)	656 × 492 pixels (Format_7 Mode_0)
Lens mount	Adjustable C-Mount: 17.526 mm (in air); Ø 25.4 mm (32 tpi) Maximum protrusion: 10.1 mm (see <a href="#">figure 22: on page 72</a> )
ADC	12-bit
Color modes	Guppy PRO F-032C: Raw8, Raw12, Raw16, Mono8, YUV411, YUV422, RGB8
Frame rates	1.875 fps; 3.75 fps; 7.5 fps; 15 fps; 30 fps; 60 fps Up to 82 fps in Format_7
Gain control	Manual: 0 to 24.4 dB (0.0359 dB/step); auto gain (select. AOI)
Shutter speed	37 μs to 67,108,864 μs (~ 67 s); auto shutter (select. AOI)
External trigger shutter	Programmable, trigger level control, single trigger, bulk trigger, programmable trigger delay
Look-up tables	User-programmable (12-bit → 10-bit); default gamma (0.45)
Smart functions	Auto gain control (AGC), auto exposure control (AEC), autofunction AOI, look-up table (LUT), 1 storable user set  Guppy PRO F-032B: Binning, sub-sampling Guppy PRO F-032C: Auto white balance (AWB), color correction, hue, saturation
I/Os	1 configurable input (optocoupled), 3 configurable outputs (optocoupled)
Transfer rate	100 Mbit/s, 200 Mbit/s, 400 Mbit/s, 800 Mbit/s
Digital interface	IEEE1394b (IIDC V1.31), 1 × copper connector
Power requirements	DC 8 V to 36 V via IEEE1394 cable or 12-pin Hirose
Power consumption	Typical <3.5 watt @ 12 VDC (full resolution and maximum frame rate)
Dimensions (L × W × H)	44.8 x 29 x 29 mm
Mass (typical)	75 g 80 g with filter ring
Operating temperature	+ 5 °C to + 45 °C ambient temperature (non-condensing)
Storage temperature	- 10 °C to + 70 °C ambient temperature (non-condensing)
Standard accessories	Guppy PRO F-032B: Protection glass   Guppy PRO F-032C: IR cut filter
Optional accessories	Guppy PRO F-032B: IR cut filter, IR pass filter   Guppy PRO F-032C: Protection glass
On request	Host adapter card, power out 6 W (Hirose)
Software packages	<a href="http://www.alliedvision.com/en/support/software-downloads">www.alliedvision.com/en/support/software-downloads</a>

Table 8: Guppy PRO F-032B, F-032C model specifications

## Guppy PRO F-033B, F-033C

Feature	Specification
Sensor	Sony ICX414AL/AQ with HAD microlens CCD, progressive scan Type 1/2 (8mm diagonal)
Effective chip size	7.48 mm × 6.15 mm
Cell size	9.9 μm × 9.9 μm
Picture size (max.)	656 × 492 pixels (Format_7 Mode_0)
Lens mount	Adjustable C-Mount: 17.526 mm (in air); ∅ 25.4 mm (32 tpi) Maximum protrusion: 10.1 mm (see <a href="#">figure 22: on page 72</a> )
ADC	14-bit
Color modes	Guppy PRO F-033C: Raw8, Raw12, Raw16, Mono8, YUV411, YUV422, RGB8
Frame rates	1.875 fps; 3.75 fps; 7.5 fps; 15 fps; 30 fps; 60 fps Up to 85 fps in Format_7
Gain control	Manual: 0 to 24.4 dB (0.0359 dB/step); auto gain (select. AOI)
Shutter speed	31 μs to 67,108,864 μs (~ 67 s); auto shutter (select. AOI)
External trigger shutter	Programmable, trigger level control, single trigger, bulk trigger, programmable trigger delay
Look-up tables	User-programmable (12-bit → 10-bit); default gamma (0.45)
Smart functions	Auto gain control (AGC), auto exposure control (AEC), autofunction AOI, look-up table (LUT), 1 storable user set  Guppy PRO F-033B: Binning, sub-sampling Guppy PRO F-033C: Auto white balance (AWB), color correction, hue, saturation
I/Os	1 configurable input (optocoupled), 3 configurable outputs (optocoupled)
Transfer rate	100 Mbit/s, 200 Mbit/s, 400 Mbit/s, 800 Mbit/s
Digital interface	IEEE1394b (IiDC V1.31), 1 × copper connector
Power requirements	DC 8 V to 36 V via IEEE1394 cable or 12-pin Hirose
Power consumption	Typical < 3.5 watt @ 12 VDC (full resolution and maximum frame rate)
Dimensions (L × W × H)	44.8 x 29 x 29 mm
Mass (typical)	75 g 80 g with filter ring
Operating temperature	+ 5 °C to + 45 °C ambient temperature (non-condensing)
Storage temperature	- 10 °C to + 70 °C ambient temperature (non-condensing)
Standard accessories	Guppy PRO F-033B: Protection glass   Guppy PRO F-033C: IR cut filter
Optional accessories	Guppy PRO F-033B: IR cut filter, IR pass filter   Guppy PRO F-033C: Protection glass
On request	Host adapter card, power out 6 W (Hirose)
Software packages	<a href="http://www.alliedvision.com/en/support/software-downloads">www.alliedvision.com/en/support/software-downloads</a>

Table 9: Guppy PRO F-033B, F-033C model specifications

## Guppy PRO F-046B, F-046C

Feature	Specification
Sensor	Sony ICX415AL/AQ with HAD microlens CCD, progressive scan Type 1/2 (8mm diagonal)
Effective chip size	7.48 mm × 6.15 mm
Cell size	8.3 μm × 8.3 μm
Picture size (max.)	780 × 580 pixels (Format_7 Mode_0)
Lens mount	Adjustable C-Mount: 17.526 mm (in air); ∅ 25.4 mm (32 tpi) Maximum protrusion: 10.1 mm (see <a href="#">figure 22: on page 72</a> )
ADC	14-bit
Color modes	Guppy PRO F-046C: Raw8, Raw12, Raw16, Mono8, YUV411, YUV422, RGB8
Frame rates	1.875 fps; 3.75 fps; 7.5 fps; 15 fps; 30 fps; 60 fps Up to 62 fps in Format_7
Gain control	Manual: 0 to 24.4 dB (0.0359 dB/step); auto gain (select. AOI)
Shutter speed	31 μs to 67,108,864 μs (~ 67 s); auto shutter (select. AOI)
External trigger shutter	Programmable, trigger level control, single trigger, bulk trigger, programmable trigger delay
Look-up tables	User-programmable (12-bit → 10-bit); default gamma (0.45)
Smart functions	Auto gain control (AGC), auto exposure control (AEC), autofunction AOI, look-up table (LUT), 1 storable user set  Guppy PRO F-046B: Binning, sub-sampling Guppy PRO F-046C: Auto white balance (AWB), color correction, hue, saturation
I/Os	1 configurable input (optocoupled), 3 configurable outputs (optocoupled)
Transfer rate	100 Mbit/s, 200 Mbit/s, 400 Mbit/s, 800 Mbit/s
Digital interface	IEEE1394b (IiDC V1.31), 1 × copper connector
Power requirements	DC 8 V to 36 V via IEEE1394 cable or 12-pin Hirose
Power consumption	Typical < 3.5 watt @ 12 VDC (full resolution and maximum frame rate)
Dimensions (L × W × H)	44.8 × 29 × 29 mm
Mass (typical)	75 g 80 g with filter ring
Operating temperature	+ 5 °C to + 45 °C ambient temperature (non-condensing)
Storage temperature	- 10 °C to + 70 °C ambient temperature (non-condensing)
Standard accessories	Guppy PRO F-046B: Protection glass   Guppy PRO F-046C: IR cut filter
Optional accessories	Guppy PRO F-046B: IR cut filter, IR pass filter   Guppy PRO F-046C: Protection glass
On request	Host adapter card, power out 6 W (Hirose)
Software packages	<a href="http://www.alliedvision.com/en/support/software-downloads">www.alliedvision.com/en/support/software-downloads</a>

Table 10: Guppy PRO F-046B, F-046C model specifications



## Guppy PRO F-125B, F-125C

Feature	Specification
Sensor	Sony ICX445ALA/AQA with EXview HAD microlens CCD, progressive scan Type 1/3 (6 mm diagonal)
Effective chip size	4.8 mm × 3.6 mm
Cell size	3.75 μm × 3.75 μm
Picture size (max.)	1292 × 964 pixels (Format_7 Mode_0)
Lens mount	Adjustable C-Mount: 17.526 mm (in air); ∅ 25.4 mm (32 tpi) Maximum protrusion: 10.1 mm (see <a href="#">figure 22: on page 72</a> )
ADC	14-bit
Color modes	Guppy PRO F-125C: Raw8, Raw12, Raw16, Mono8, YUV411, YUV422, RGB8
Frame rates	1.875 fps; 3.75 fps; 7.5 fps; 15 fps; 30 fps; 60 fps Up to 31 fps in Format_7
Gain control	Manual: 0 to 24.4 dB (0.0359 dB/step); auto gain (select. AOI)
Shutter speed	39 μs to 67,108,864 μs (~ 67 s); auto shutter (select. AOI)
External trigger shutter	Programmable, trigger level control, single trigger, bulk trigger, programmable trigger delay
Look-up tables	User-programmable (12-bit → 10-bit); default gamma (0.45)
Smart functions	Auto gain control (AGC), auto exposure control (AEC), autofunction AOI, look-up table (LUT), 1 storable user set  Guppy PRO F-125B: Binning, sub-sampling Guppy PRO F-125C: Auto white balance (AWB), color correction, hue, saturation
I/Os	1 configurable input (optocoupled), 3 configurable outputs (optocoupled)
Transfer rate	100 Mbit/s, 200 Mbit/s, 400 Mbit/s, 800 Mbit/s
Digital interface	IEEE1394b (IiDC V1.31), 1 × copper connector
Power requirements	DC 8 V to 36 V via IEEE1394 cable or 12-pin Hirose
Power consumption	Typical <3.5 watt @ 12 VDC (full resolution and maximum frame rate)
Dimensions (L × W × H)	44.8 x 29 x 29 mm
Mass (typical)	75 g 80 g with filter ring
Operating temperature	+ 5 °C to + 45 °C ambient temperature (non-condensing)
Storage temperature	- 10 °C to + 70 °C ambient temperature (non-condensing)
Standard accessories	Guppy PRO F-125B: Protection glass   Guppy PRO F-125C: IR cut filter
Optional accessories	Guppy PRO F-125B: IR cut filter, IR pass filter   Guppy PRO F-125C: Protection glass
On request	Host adapter card, power out 6 W (Hirose)
Software packages	<a href="http://www.alliedvision.com/en/support/software-downloads">www.alliedvision.com/en/support/software-downloads</a>

Table 11: Guppy PRO F-125B, F-125C model specifications

## Guppy PRO F-146B, F-146C

Feature	Specification
Sensor	Sony ICX267AL/AK with HAD microlens CCD, progressive scan Type 1/2 (8 mm diagonal)
Effective chip size	6.5 mm × 4.8 mm
Cell size	4.65 μm × 4.65 μm
Picture size (max.)	1388 × 1038 pixels (Format_7 Mode_0)
Lens mount	Adjustable C-Mount: 17.526 mm (in air); ∅ 25.4 mm (32 tpi) Maximum protrusion: 10.1 mm (see <a href="#">figure 22: on page 72</a> )
ADC	12-bit
Color modes	Guppy PRO F-146C: Raw8, Raw12, Raw16, Mono8, YUV411, YUV422, RGB8
Frame rates	1.875 fps; 3.75 fps; 7.5 fps; 15 fps; 30 fps (Guppy PRO F-146C) Up to 17 fps in Format_7
Gain control	Manual: 0 to 24.4 dB (0.0359 dB/step); auto gain (select. AOI)
Shutter speed	41 μs to 67,108,864 μs (~ 67 s); auto shutter (select. AOI)
External trigger shutter	Programmable, trigger level control, single trigger, bulk trigger, programmable trigger delay
Look-up tables	User-programmable (12-bit → 10-bit); default gamma (0.45)
Smart functions	Auto gain control (AGC), auto exposure control (AEC), autofunction AOI, look-up table (LUT), 1 storable user set  Guppy PRO F-146B: Binning, sub-sampling Guppy PRO F-146C: Auto white balance (AWB), color correction, hue, saturation
I/Os	1 configurable input (optocoupled), 3 configurable outputs (optocoupled)
Transfer rate	100 Mbit/s, 200 Mbit/s, 400 Mbit/s, 800 Mbit/s
Digital interface	IEEE1394b (iDC V1.31), 1 × copper connector
Power requirements	DC 8 V to 36 V via IEEE1394 cable or 12-pin Hirose
Power consumption	Typical <3.5 watt @ 12 VDC (full resolution and maximum frame rate)
Dimensions (L × W × H)	44.8 x 29 x 29 mm
Mass (typical)	75 g 80 g with filter ring
Operating temperature	+ 5 °C to + 45 °C ambient temperature (non-condensing)
Storage temperature	- 10 °C to + 70 °C ambient temperature (non-condensing)
Standard accessories	Guppy PRO F-146B: Protection glass   Guppy PRO F-146C: IR cut filter
Accessories	Guppy PRO F-146B: IR cut filter, IR pass filter   Guppy PRO F-146C: Protection glass
On request	Host adapter card, power out 6 W (Hirose)
Software packages	<a href="http://www.alliedvision.com/en/support/software-downloads">www.alliedvision.com/en/support/software-downloads</a>

Table 12: Guppy PRO F-146B, F-146C model specifications

## Guppy PRO F-201B, F-201C

Feature	Specification
Sensor	Sony ICX274AL/AQ with Super HAD microlens CCD, progressive scan Type 1/1.8 (8.9 mm diagonal)
Effective chip size	7.1 mm × 5.4 mm
Cell size	4.40 μm × 4.40 μm
Picture size (max.)	1624 × 1234 pixels (Format_7 Mode_0)
Lens mount	Adjustable C-Mount: 17.526 mm (in air); ∅ 25.4 mm (32 tpi) Maximum protrusion: 10.1 mm (see <a href="#">figure 22: on page 72</a> )
ADC	12-bit
Color modes	Guppy PRO F-201C: Raw8, Raw12, Raw16, Mono8, YUV411, YUV422, RGB8
Frame rates	1.875 fps; 3.75 fps; 7.5 fps; 15fps; 30 fps Up to 14 fps in Format_7
Gain control	Manual: 0 to 24.4 dB (0.0359 dB/step); auto gain (select. AOI)
Shutter speed	55 μs to 67,108,864 μs (~ 67 s); auto shutter (select. AOI)
External trigger shutter	Programmable, trigger level control, single trigger, bulk trigger, programmable trigger delay
Look-up tables	User-programmable (12-bit → 10-bit); default gamma (0.45)
Smart functions	Auto gain control (AGC), auto exposure control (AEC), autofunction AOI, look-up table (LUT), 1 storable user set  Guppy PRO F-201B: Binning, sub-sampling Guppy PRO F-201C: Auto white balance (AWB), color correction, hue, saturation
I/Os	1 configurable input (optocoupled), 3 configurable outputs (optocoupled)
Transfer rate	100 Mbit/s, 200 Mbit/s, 400 Mbit/s, 800 Mbit/s
Digital interface	IEEE1394b (IIDC V1.31), 1 × copper connector
Power requirements	DC 8 V to 36 V via IEEE1394 cable or 12-pin Hirose
Power consumption	Typical < 3.5 watt @ 12 VDC (full resolution and maximum frame rate)
Dimensions (L × W × H)	44.8 x 29 x 29 mm
Mass (typical)	75 g 80 g with filter ring
Operating temperature	+ 5 °C to + 45 °C ambient temperature (non-condensing)
Storage temperature	- 10 °C to + 70 °C ambient temperature (non-condensing)
Standard accessories	Guppy PRO F-201B: Protection glass   Guppy PRO F-201C: IR cut filter
Optional accessories	Guppy PRO F-201B: IR cut filter, IR pass filter   Guppy PRO F-201C: Protection glass
On request	Host adapter card, power out 6 W (Hirose)
Software packages	<a href="http://www.alliedvision.com/en/support/software-downloads">www.alliedvision.com/en/support/software-downloads</a>

Table 13: Guppy PRO F-201B, F-201C model specifications

## Guppy PRO F-503B, F-503C

Feature	Specification
Sensor	ON Semiconductor (Aptina) MT9P031 with microlens CMOS Type 1/2.5 (7.13 mm diagonal)
Shutter type	Electronic rolling shutter (ERS), Global reset release shutter (GRR)
Effective chip size	5.7 mm × 4.3 mm
Cell size	2.2 μm × 2.2 μm
Picture size (max.)	2588 × 1940 pixels (Format_7 Mode_0)
Lens mount	Adjustable C-Mount: 17.526 mm (in air); Ø 25.4 mm (32 tpi) Maximum protrusion: 10.1 mm (see <a href="#">figure 22: on page 72</a> )
ADC	12-bit
Color modes	Guppy PRO F-503C: Raw8, Raw12, Raw16, Mono8/12/16 (all F7 modes), YUV411 (all F7 modes), YUV422 (all F7 modes)
Frame rates	1.875 fps; 3.75 fps; 7.5 fps; 15 fps; 30 fps; 60 fps; 120 fps; Format_7: variable frame rates up to 13 fps at full resolution; (64x64: up to ~ 830 fps)
Gain control	Manual: 0 to 12.04 dB (~0.125/step (1.02- 0.28 dB/step)) 12.57 to 18.06 dB (~0.5/step (0.53- 0.28 dB/step)) Auto gain (select. AOI)
Shutter speed	20 μs to ~ 22.37 s
External trigger shutter	Edge mode, programmable trigger delay
Look-up tables	User-programmable (12-bit → 10-bit); default gamma (0.45)
Smart functions	Auto gain control (AGC), auto exposure control (AEC), autofunction AOI, look-up table (LUT), mirror, binning, low-noise binning mode, sub-sampling, defect pixel correction, 1 storable user set  Guppy PRO F-503C: Auto white balance (AWG), color correction, hue, saturation
I/Os	1 configurable input (optocoupled), 3 configurable outputs (optocoupled)
Transfer rate	100 Mbit/s, 200 Mbit/s, 400 Mbit/s, 800 Mbit/s
Digital interface	IEEE1394b (iIDC V1.31), 1 × copper connector
Power requirements	DC 8 V to 36 V via IEEE1394 cable or 12-pin Hirose
Power consumption	Typical < 3.5 watt @ 12 VDC (full resolution and maximum frame rate)
Dimensions (L × W × H)	44.8 x 29 x 29 mm
Mass (typical)	75 g 80 g with filter ring
Operating temperature	+ 5 °C to + 45 °C ambient temperature (non-condensing)
Storage temperature	- 10 °C to + 70 °C ambient temperature (non-condensing)
Standard accessories	Guppy PRO F-503B: Protection glass   Guppy PRO F-503C: IR cut filter
Optional accessories	Guppy PRO F-503B: IR cut filter, IR pass filter   Guppy PRO F-503C: Protection glass
On request	Host adapter card, power out 6 W (Hirose)
Software packages	<a href="http://www.alliedvision.com/en/support/software-downloads">www.alliedvision.com/en/support/software-downloads</a>

Table 14: Guppy PRO F-503B, F-503C model specifications

## Spectral sensitivity

### Absolute quantum efficiency (QE)

**Note**

Measurements for color cameras were done with IR cut filter, measurements for monochrome and S-Mount cameras were done without optical filters. With optical filters, QE decreases by approximately 10 percent. The uncertainty in measurement of the QE values is  $\pm 10$  percent. This is mainly due to uncertainties in the measuring apparatus itself (such as Ulbricht sphere and optometer).

Manufacturing tolerance of the sensor increases overall uncertainty.

**Note**

Sony provides relative response curves in their sensor data sheets. To create the absolute QE plots shown in this chapter, the relative response was converted to a normalized QE response and then adjusted as per three measured QE values (at 448 nm, 529 nm, 632 nm) for color sensors and one measured QE value (at 529 nm) for monochrome sensors.

**Note**

Absolute QE plots for ON Semiconductor CMOS sensors

The curve in the absolute QE plots shown in this chapter is from the sensor manufacturer data sheet. The information was correct at the time of publishing.

**Note**

The wavelength range in the absolute QE plots reflects the information available in the sensor manufacturer data sheet at the time of publishing. For additional wavelength information, contact the sensor manufacturer.

### Spectral response plots

**Note**

The curves in the spectral response plots shown in this chapter were calculated from measured quantum efficiencies at 448 nm, 529 nm, and 632 nm. The shape of the curve is taken from the sensor data sheet but the values have been adjusted based on these measured values. The uncertainty in measurement of the spectral response values is  $\pm 10$  percent.

**Guppy PRO F-031B, F-031C**

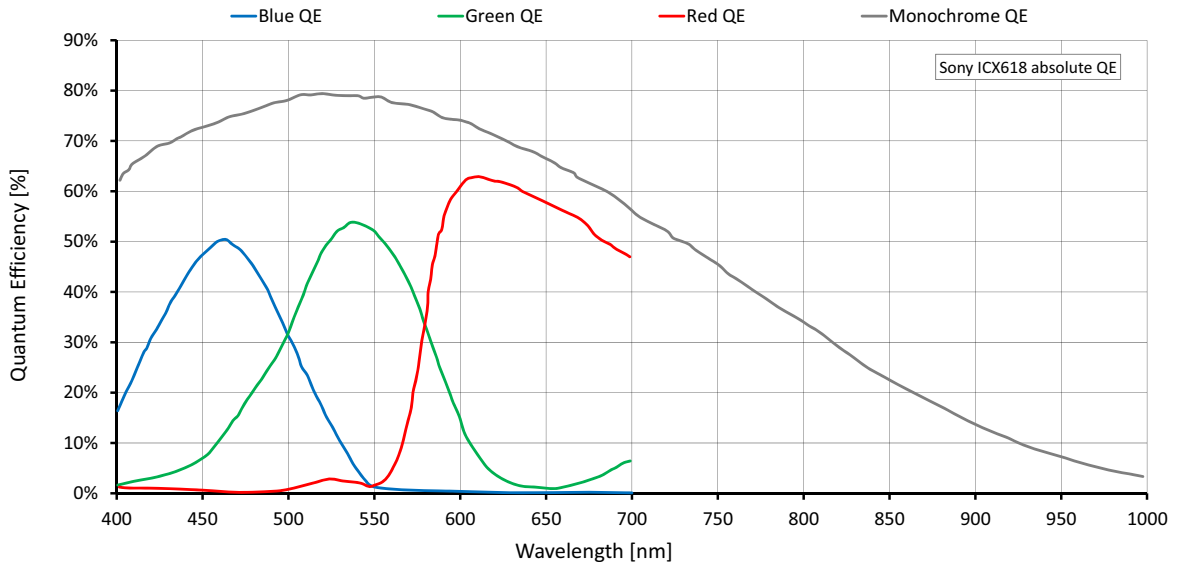

Figure 5: Guppy PRO F-031B, F-031C (Sony ICX618) absolute QE

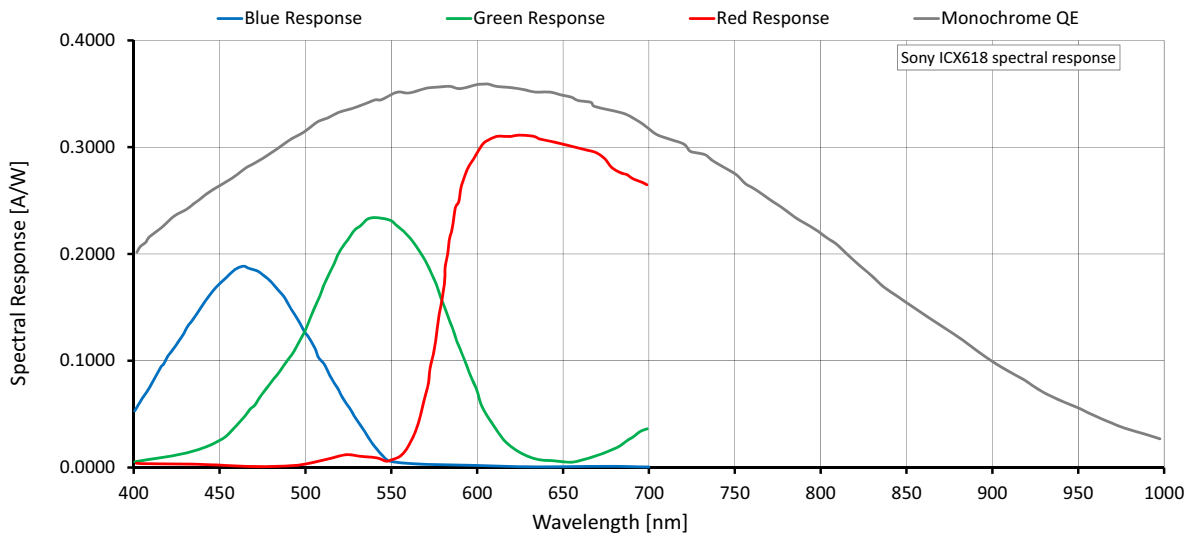

Figure 6: Guppy PRO F-031B, F-031C (Sony ICX618) spectral response

Guppy PRO F-032B, F-032C

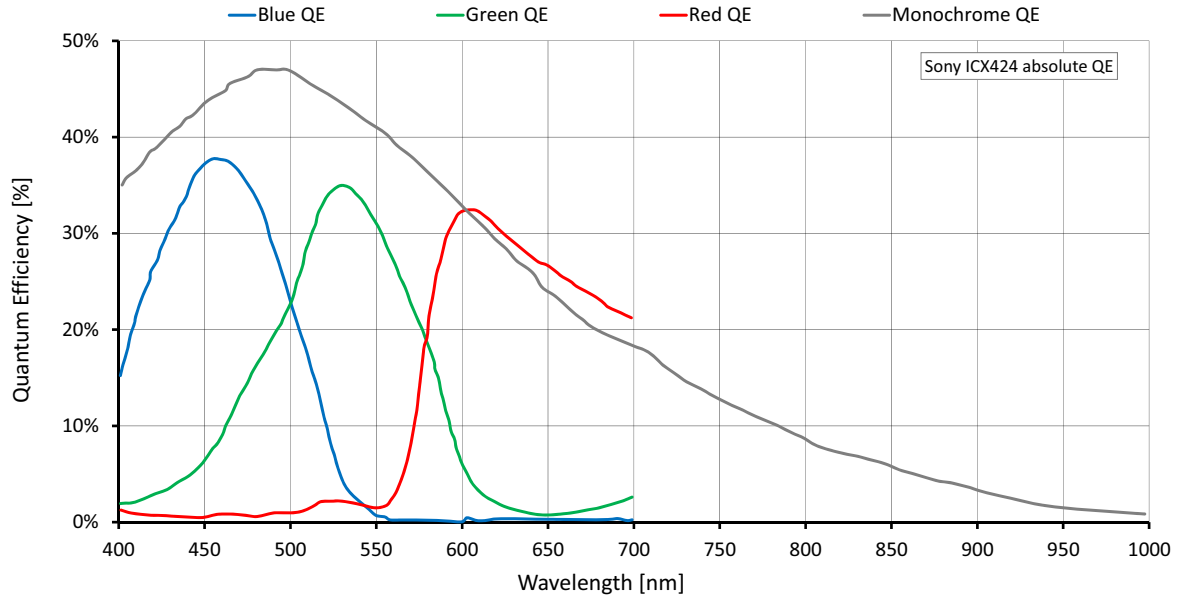

Figure 7: Guppy PRO F-032B, F-032C (Sony ICX424) absolute QE

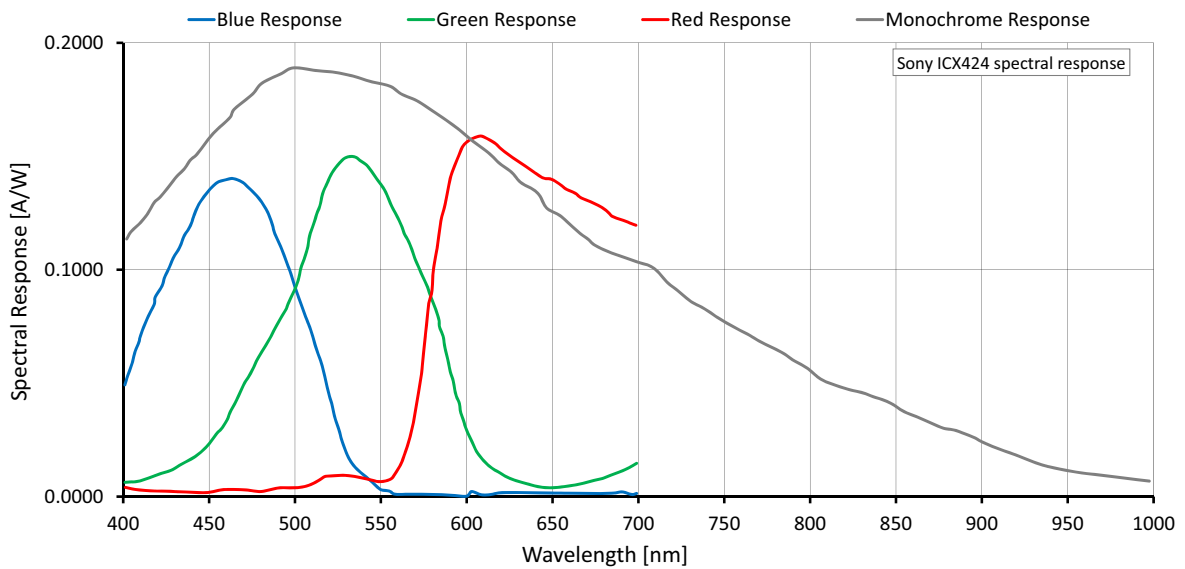

Figure 8: Guppy PRO F-032B, F-032C (Sony ICX424) spectral response

### Guppy PRO F-033B, F-033C

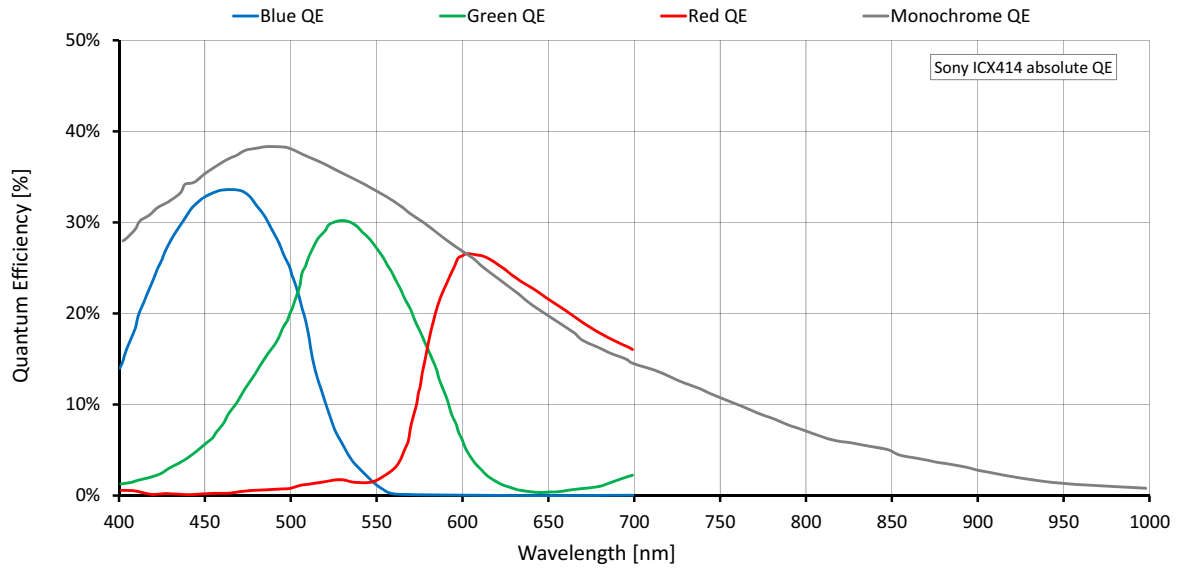

Figure 9: Guppy PRO F-033B, F-033C (Sony ICX414) absolute QE

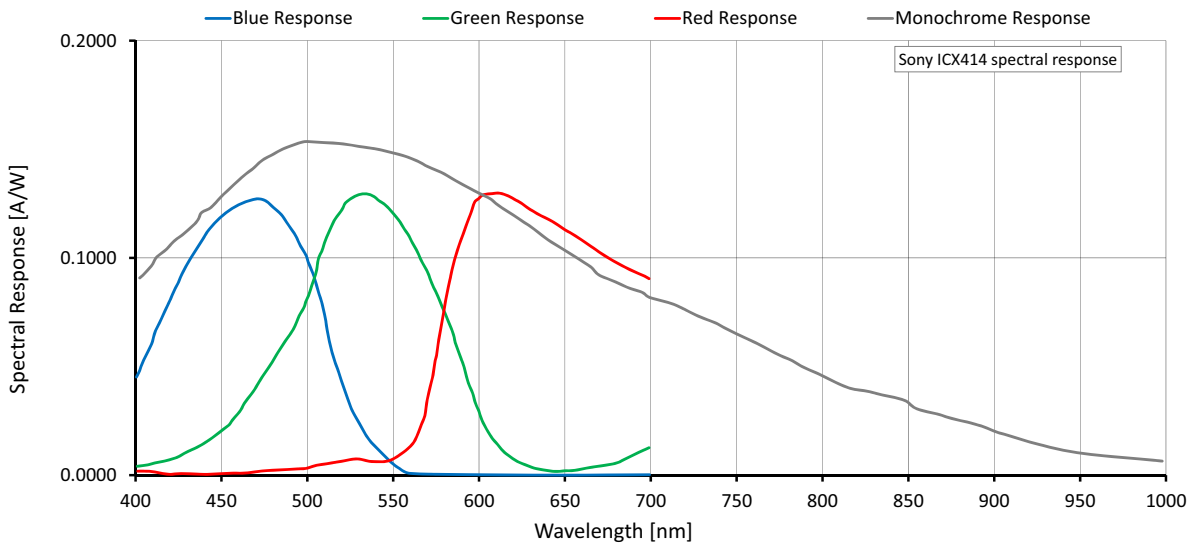

Figure 10: Guppy PRO F-033B, F-033C (Sony ICX414) spectral response



Guppy PRO F-046B, F-046C

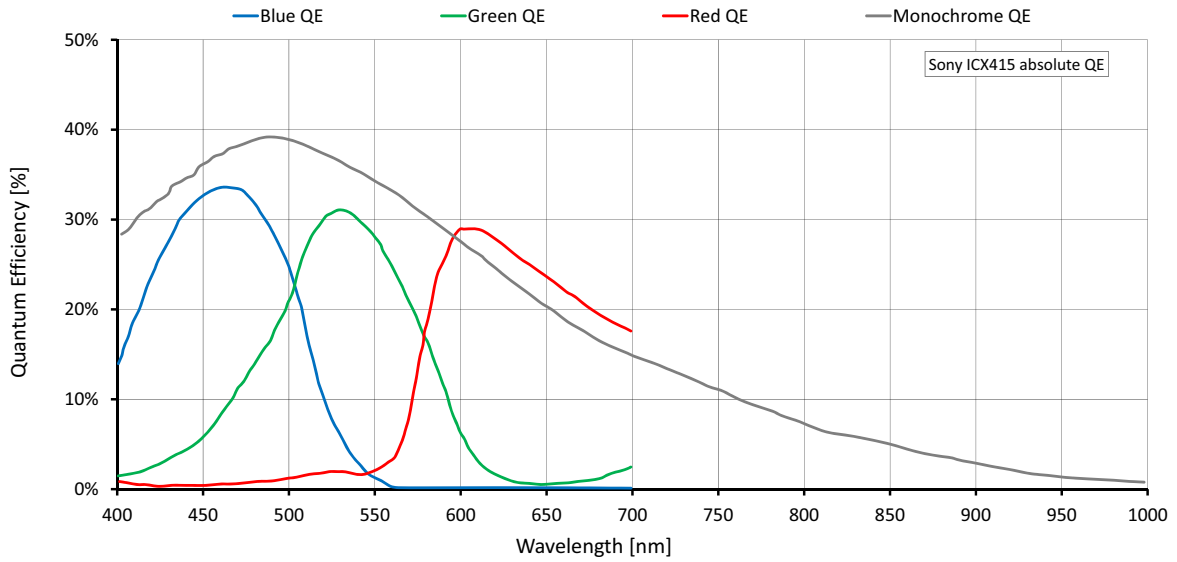

Figure 11: Guppy PRO F-046B, F-046C (Sony ICX415) absolute QE

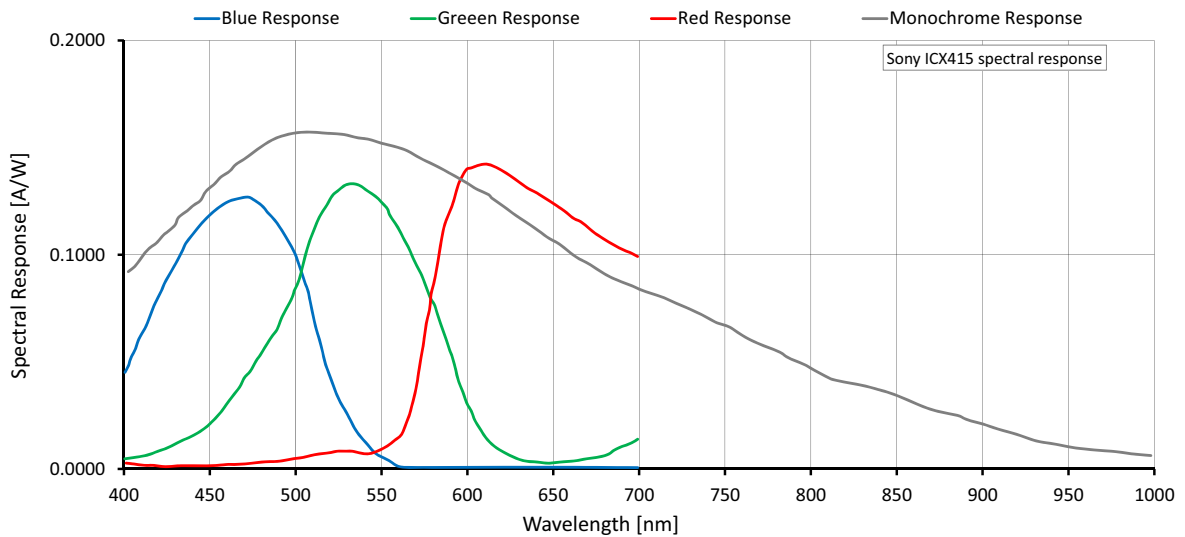

Figure 12: Guppy PRO F-046B, F-046C (Sony ICX415) spectral response

**Guppy PRO F-125B, F-125C**

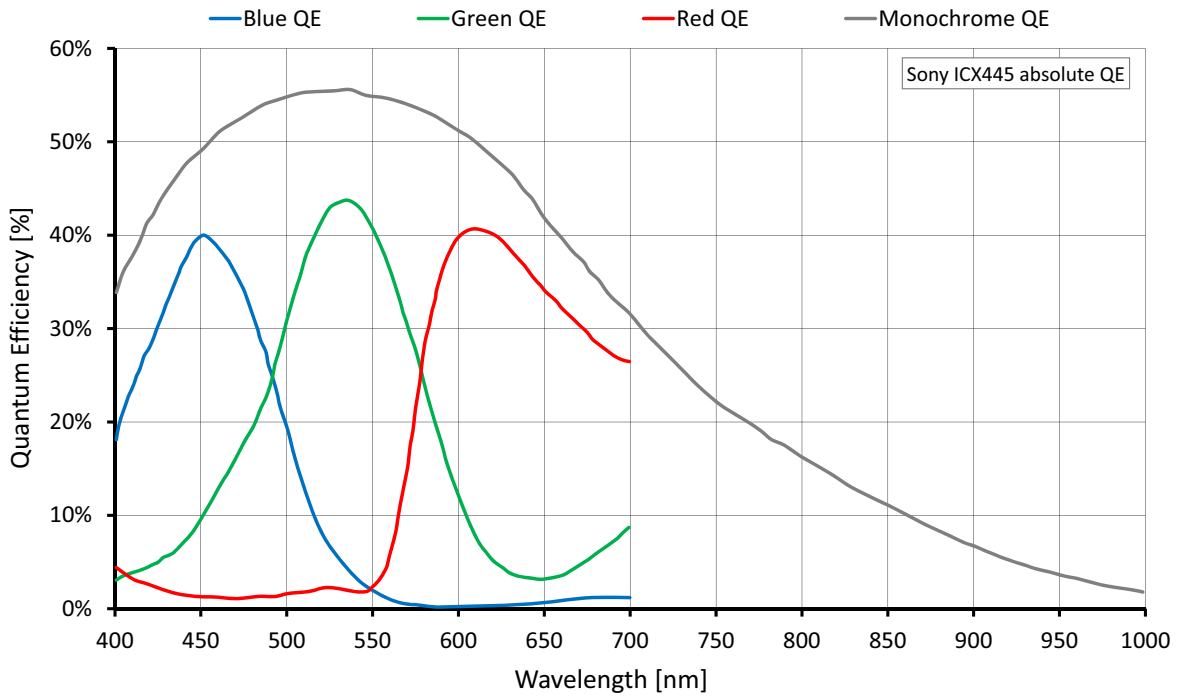

Figure 13: Guppy PRO F-125B, F-125C (Sony ICX445) absolute QE

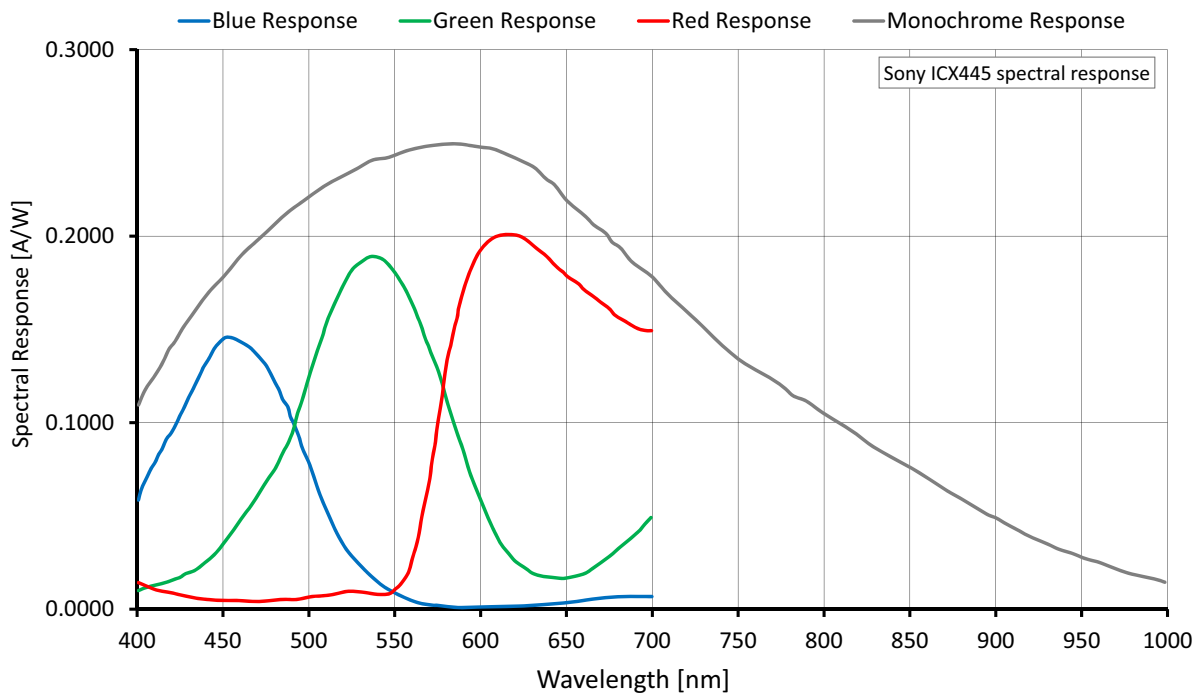

Figure 14: Guppy PRO F-125B, F-125C (Sony ICX445) spectral response

**Guppy PRO F-146B, F-146C**

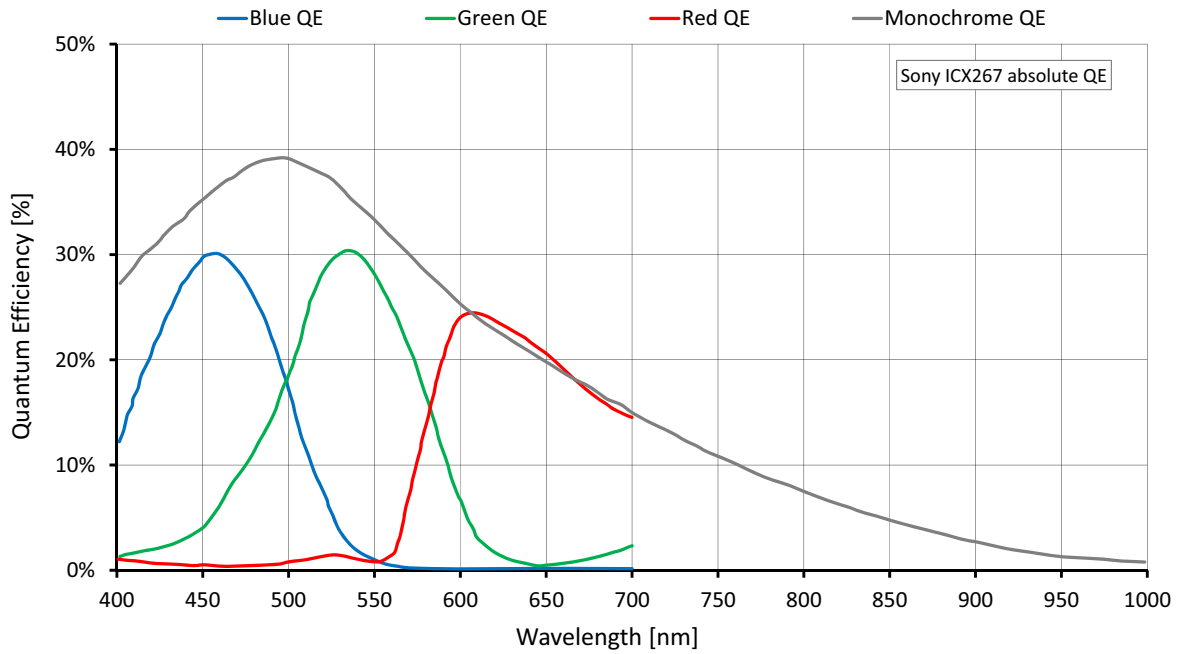

Figure 15: Guppy PRO F-146B, F-146C (Sony ICX267) absolute QE

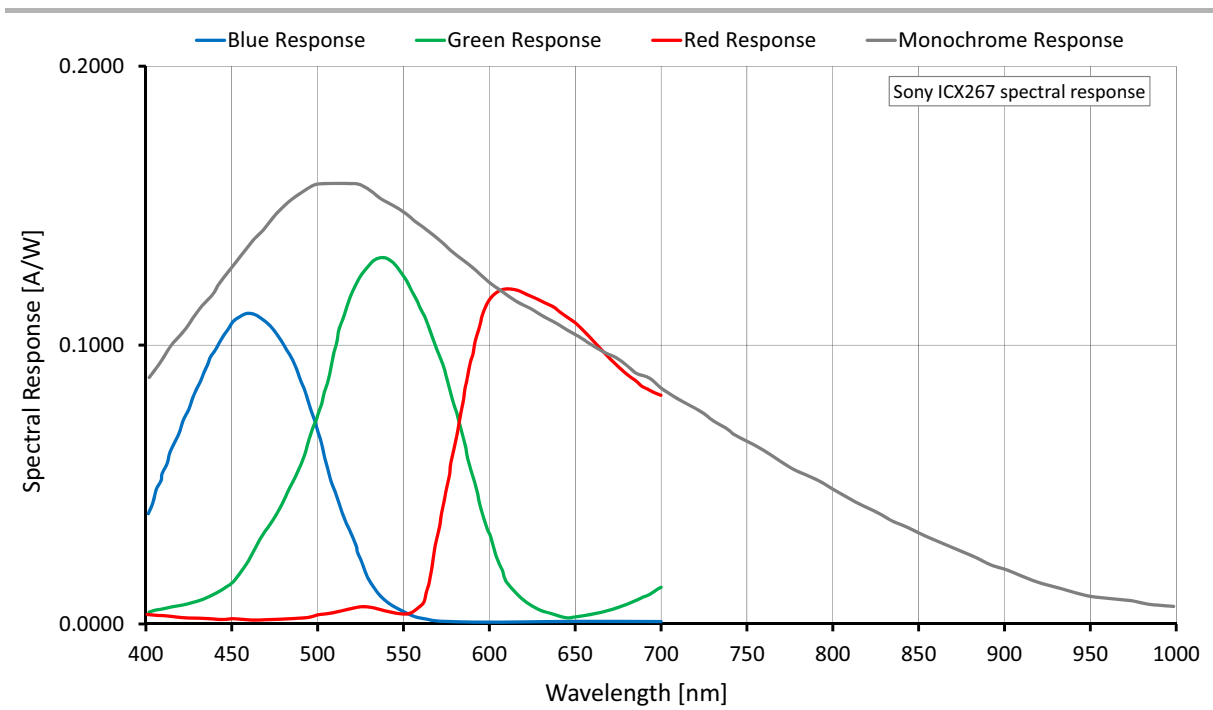

Figure 16: Guppy PRO F-146B, F-146C (Sony ICX267) spectral response

Guppy PRO F-201B, F-201C

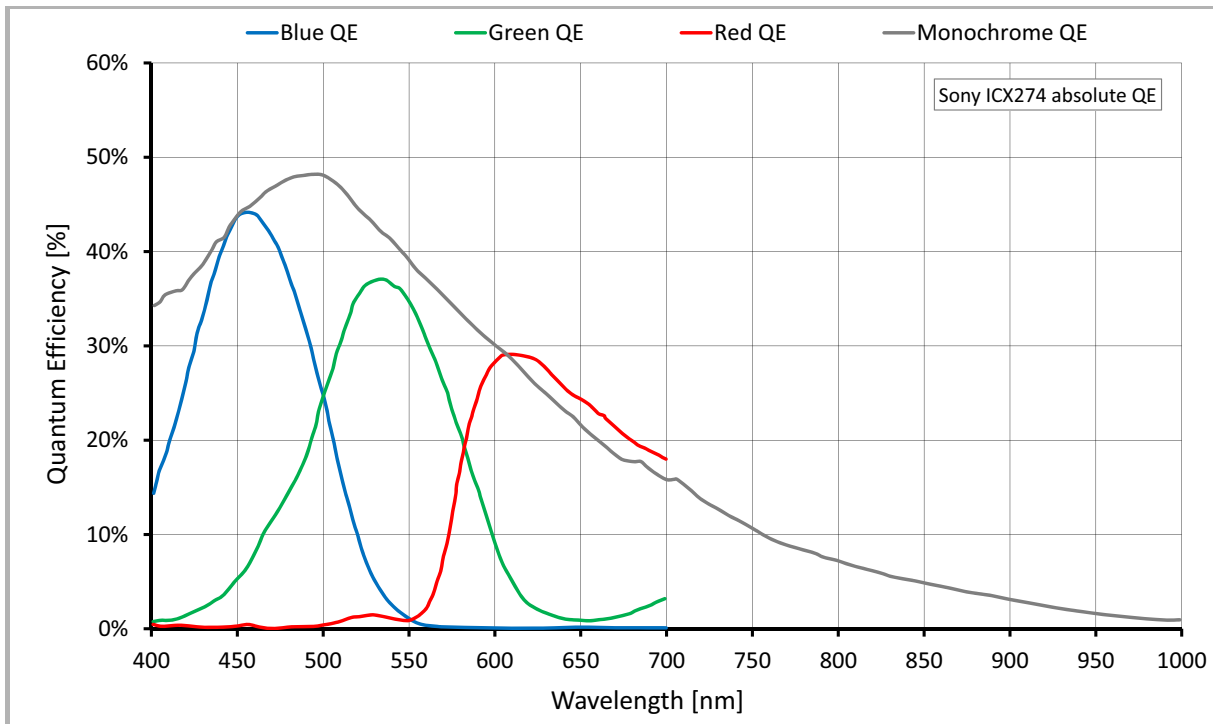

Figure 17: Guppy PRO F-201B, F-201C (Sony ICX274) absolute QE

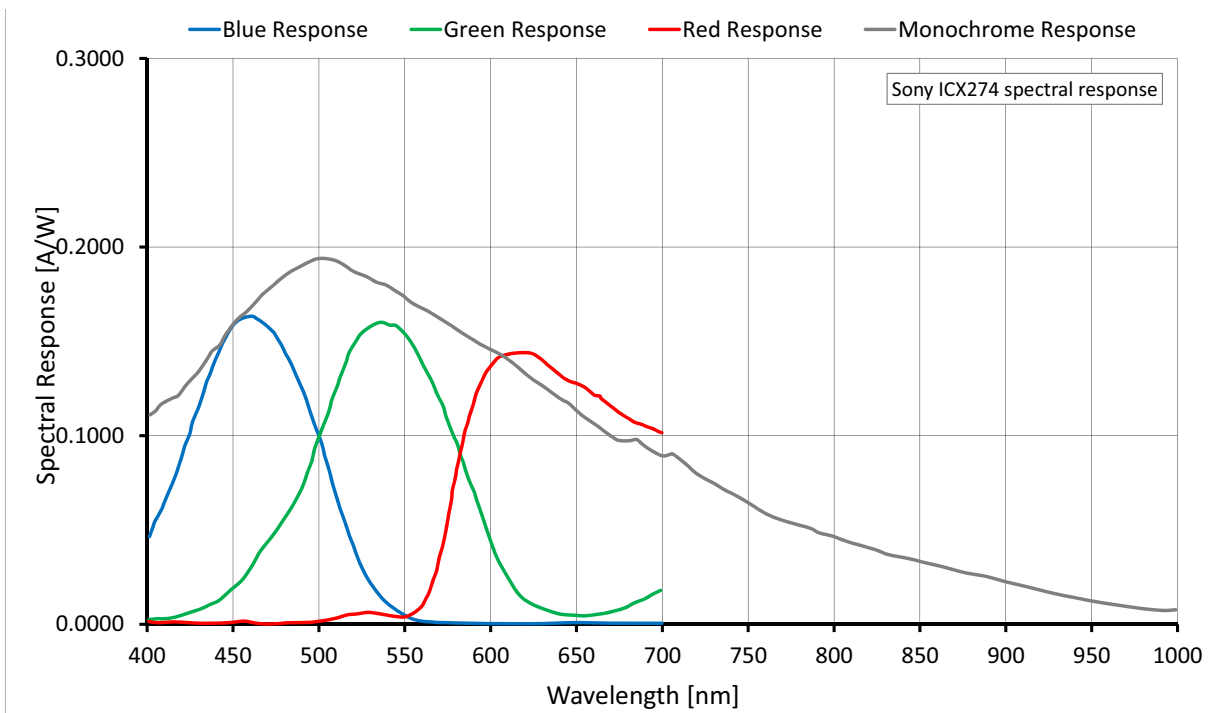

Figure 18: Guppy PRO F-201B, F-201C (Sony ICX274) spectral response

Guppy PRO F-503B, F-503C

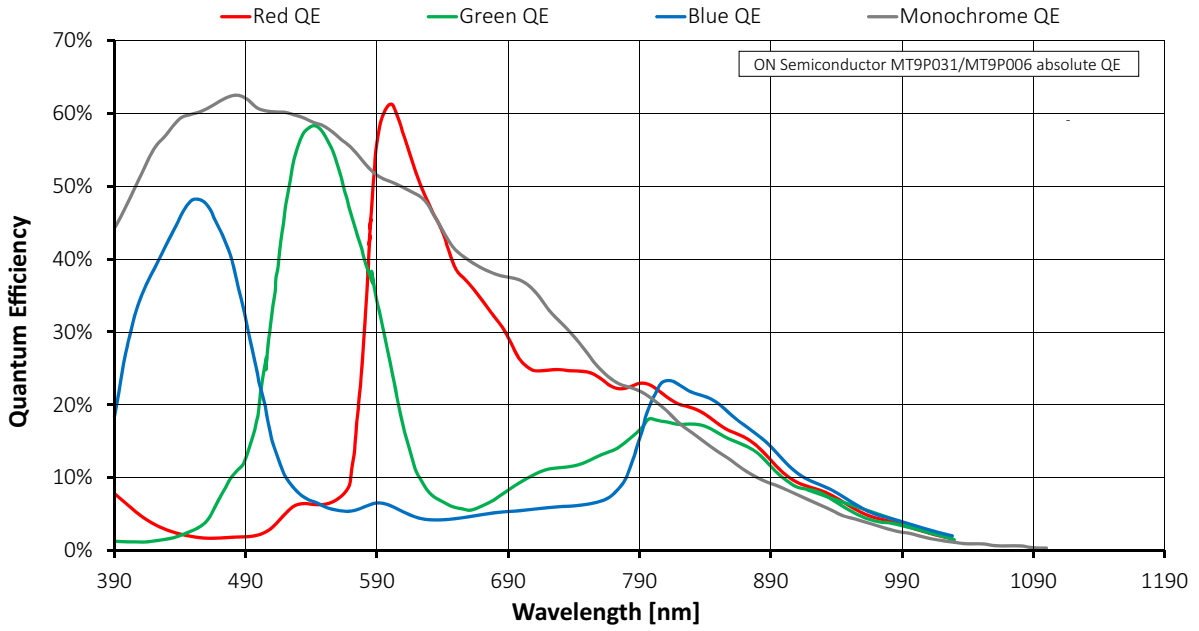

Figure 19: Guppy PRO F-503B, F-503C (ON Semiconductor MT9P031) absolute QE

## Camera dimensions

**Note**

For information on sensor position accuracy:



See [Sensor position accuracy of Guppy PRO cameras](#) on page 257.

### Guppy PRO standard housing (1 × IEEE1394b copper)

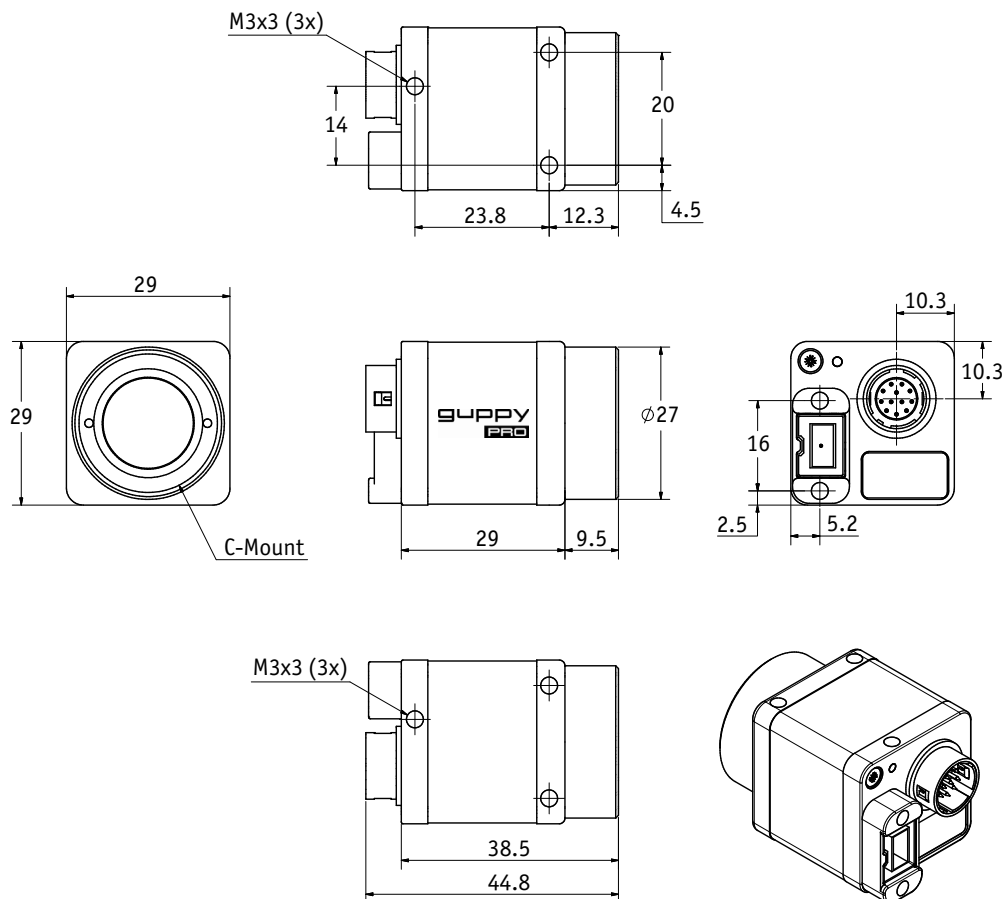

Figure 20: Camera dimensions (1 × IEEE1394b copper)

## Tripod adapter

This three hole tripod adapter (Allied Vision order code 1216) to

- to can be used for Guppy PRO only.
- to is only designed for standard housings.

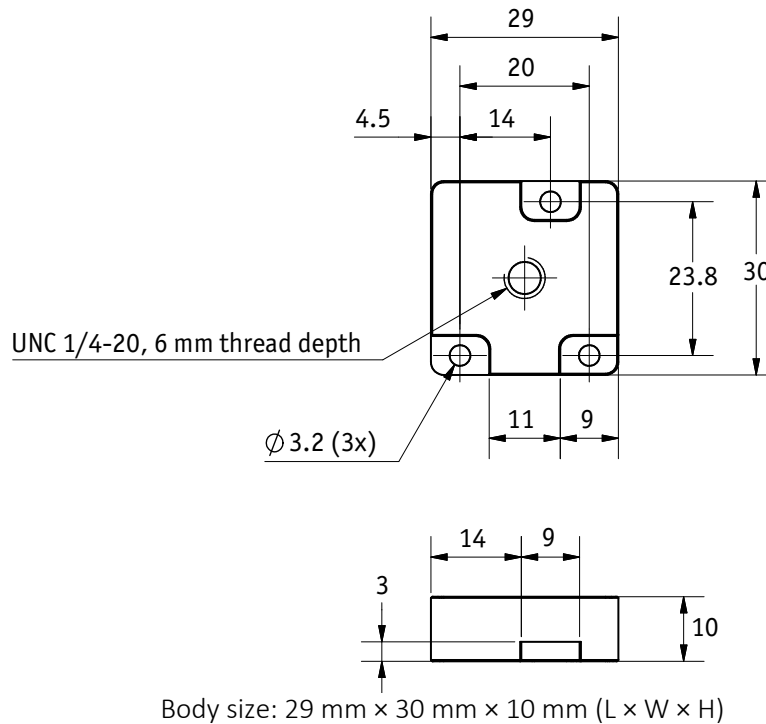

Figure 21: Tripod dimensions

## Maximum protrusion: C-Mount



### NOTICE

#### Damage to sensor, optics, or electronics by unsuitable lenses or objects

The sensor, filter, lens, or camera electronics can be damaged if an object (typically a lens) exceeding maximum protrusion is mounted to the camera.

- Mount only lenses or objects with less than 10.7 mm for maximum protrusion, see [Figure 22](#).



#### Maximum protrusion value

Temporarily, a different filter holder was used. With V4.2.3 of this document, manufacturing returns to the previous filter holder. By mistake, [Figure 22](#) was not updated for the temporary change. Therefore, it reflects the current state.

Please observe that maximum protrusion has temporarily been 13.2 mm. The **current value is 10.7 mm** as shown in [Figure 22](#).

- All monochrome Guppy PRO cameras are equipped with the same model of protection glass.
- All color Guppy PRO cameras are equipped with the same model of IR cut filter.

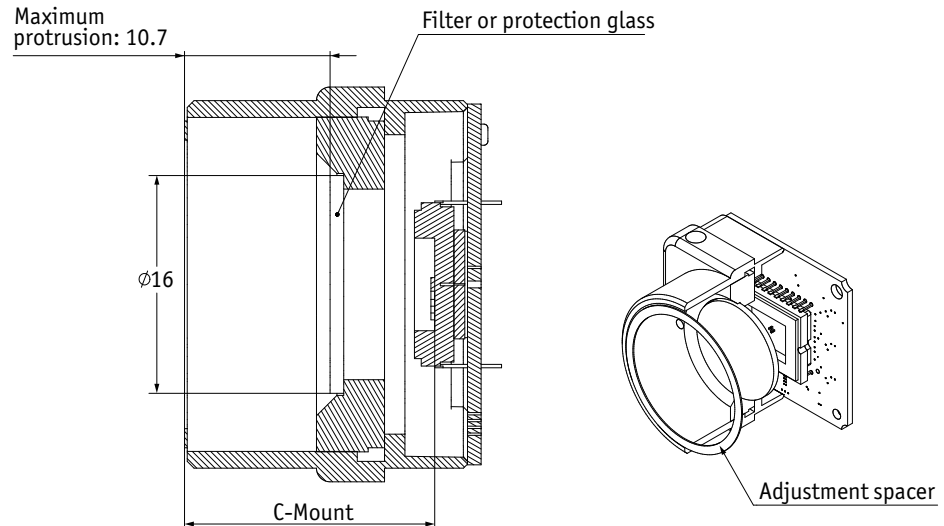

Figure 22: Guppy PRO C-Mount dimensions

#### Note



Adjustment is only made (via adjustment spacer between lens and front flange), if the customer needs accuracy below 100  $\mu\text{m}$ .



## Maximum protrusion: CS-Mount



### NOTICE

#### Damage to sensor, optics, or electronics by unsuitable lenses or objects

The sensor, filter, lens, or camera electronics can be damaged if an object (typically a lens) exceeding maximum protrusion is mounted to the camera.

- Mount only lenses or objects with less than 5.7 mm for maximum protrusion, see [Figure 23](#).



#### Maximum protrusion value

Temporarily, a different filter holder was used. With V4.2.3 of this document, manufacturing returns to the previous filter holder. By mistake, [Figure 23](#) was not updated for the temporary change. Therefore, it reflects the current state.

Please observe that maximum protrusion has temporarily been 8.2 mm. The **current value is 5.7 mm** as shown in [Figure 23](#).

All Guppy PRO cameras can be delivered with CS-Mount.

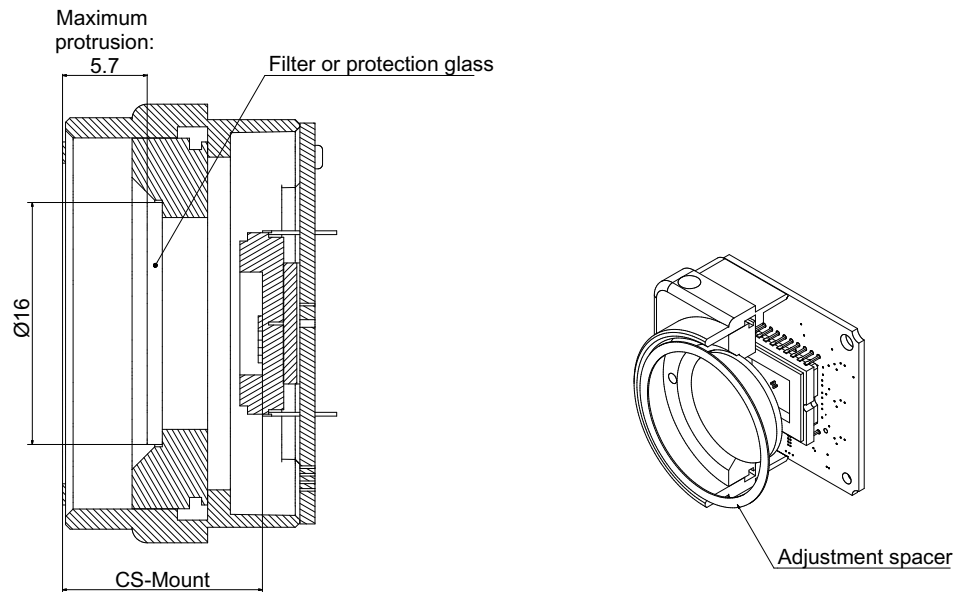

Figure 23: Guppy PRO CS-Mount dimension

#### Note

Ensure that the image circle of the lens is greater than or equal to the sensor size.



For mount options see the *Modular Concept* document.

## Adjustment of C-Mount/CS-Mount

The dimensional adjustment cannot be made by the customer. All adjustments have to be made by the Allied Vision factory.

Adjustment is only made (via adjustment spacer between lens and front flange), if the customer needs accuracy below 100  $\mu\text{m}$ .

If you need any adjustments, please contact Customer Care: For phone numbers and e-mail: See [Contact us](#) on page 15.

### Note



For all customers who know the C-Mount adjustment procedure from Pike cameras:

The front flange of Guppy PRO cameras is a fixed part of the camera (and cannot be screwed).

As mentioned above: adjustment of C-Mount with Guppy PRO cameras can only be made by Allied Vision.

## Filter and lenses

### IR cut filter: spectral transmission

The following illustration shows the spectral transmission of the IR cut filter.

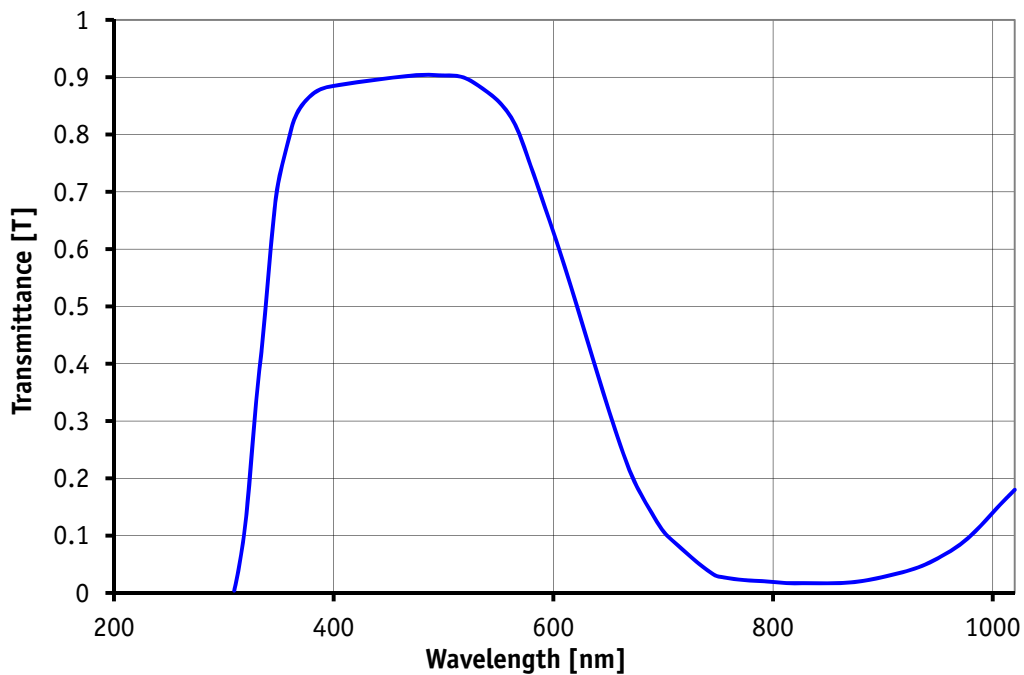

Figure 24: Typical spectral transmission of IR cut filter type Hoya C5000 (values may vary slightly by filter lot)

## Camera lenses

Allied Vision offers different lenses from a variety of manufacturers. The following table lists selected image formats in width × height depending on camera type, distance and the focal length of the lens.

#### Note



All calculations apply to the principle planes of the lenses: these are unknown (real lenses are not infinite thin).

All calculations are valid only for a distortion free optical image (among other things: not valid for fisheye lenses).

### Guppy PRO F-031

Focal length	Field of view	
	Distance = 500 mm	Distance = 1000 mm
2.8 mm	652 mm × 492 mm	1307 mm × 987 mm
4 mm	455 mm × 343 mm	914 mm × 690 mm
4.2 mm	433 mm × 327 mm	870 mm × 657 mm
4.8 mm	379 mm × 286 mm	761 mm × 574 mm
6 mm	302 mm × 228 mm	608 mm × 459 mm
6.5 mm	279 mm × 210 mm	561 mm × 423 mm
8 mm	226 mm × 170 mm	455 mm × 343 mm
12 mm	149 mm × 113 mm	302 mm × 228 mm
16 mm	111 mm × 84 mm	226 mm × 170 mm
25 mm	70 mm × 53 mm	143 mm × 108 mm

Table 15: Guppy PRO F-031 focal length vs. field of view

### Guppy PRO F-032

Focal length	Field of view	
	Distance = 500 mm	Distance = 1000 mm
2.8 mm	867 mm × 648 mm	1738 mm × 1300 mm
4 mm	605 mm × 453 mm	1215 mm × 909 mm
4.2 mm	576 mm × 431 mm	1157 mm × 865 mm
4.8 mm	503 mm × 377 mm	1012 mm × 757 mm
6 mm	402 mm × 301 mm	808 mm × 605 mm
6.5 mm	371 mm × 277 mm	746 mm × 558 mm
8 mm	300 mm × 224 mm	605 mm × 453 mm
12 mm	198 mm × 148 mm	402 mm × 301 mm
16 mm	148 mm × 110 mm	300 mm × 224 mm
25 mm	93 mm × 69 mm	190 mm × 142 mm

Table 16: Guppy PRO F-032 focal length vs. field of view

### Guppy PRO F-033, F-046, F-146

Focal length	Field of view	
	Distance = 500 mm	Distance = 1000 mm
4.8 mm	660 mm × 495 mm	1327 mm × 995 mm
8 mm	394 mm × 295 mm	794 mm × 595 mm
12 mm	260 mm × 195 mm	527 mm × 395 mm
16 mm	194 mm × 145 mm	394 mm × 295 mm
25 mm	122 mm × 91 mm	250 mm × 187 mm
35 mm	85 mm × 64 mm	176 mm × 132 mm
50 mm	58 mm × 43 mm	122 mm × 91 mm

Table 17: Guppy PRO F-033, F-046, F-146 focal length vs. field of view

### Guppy PRO F-201

Focal length	Field of view	
	Distance = 500 mm	Distance = 1000 mm
4.8 mm	740 mm × 549 mm	1488 mm × 1103 mm
8 mm	441 mm × 327 mm	890 mm × 660 mm
12 mm	292 mm × 216 mm	591 mm × 438 mm
16 mm	217 mm × 161 mm	441 mm × 327 mm
25 mm	136 mm × 101 mm	280 mm × 207 mm
35 mm	95 mm × 71 mm	198 mm × 147 mm
50 mm	65 mm × 48 mm	136 mm × 101 mm

Table 18: Guppy PRO F-201 focal length vs. field of view

**Guppy PRO F-503**

Focal length	Field of view	
	Distance = 0.5 m	Distance = 1 m
4.8 mm	0.44 m × 0.59 m	0.89 m × 1.18 m
8 mm	0.26 m × 0.35 m	0.53 m × 0.70 m
12 mm	0.17 m × 0.23 m	0.35 m × 0.47 m
16 mm	0.13 m × 0.17 m	0.26 m × 0.35 m
25 mm	0.08 m × 0.11 m	0.17 m × 0.22 m
35 mm	0.06 m × 0.08 m	0.12 m × 0.16 m
50 mm	0.04 m × 0.05 m	0.08 m × 0.11 m

*Table 19: Guppy PRO F-503 focal length vs. field of view*

**Note**

Lenses with focal lengths < 8 mm may show shading in the edges of the image and due to micro lenses on the sensor's pixel.

Ask your Allied Vision distribution partner if you require non C-Mount lenses.

## Camera interfaces

This chapter gives you detailed information on status LEDs, inputs and outputs, trigger features and transmission of data packets.

### Note



For a detailed description of the camera interfaces (FireWire, I/O connector), and operating instructions see the *1394 Installation Manual*, Chapter *Camera interfaces*.

Read all Notes and Cautions in the *1394 Installation Manual*, before using any interfaces.

## IEEE1394b port pin assignment

The IEEE1394b connector is designed for industrial use and has the following pin assignment as per specification:

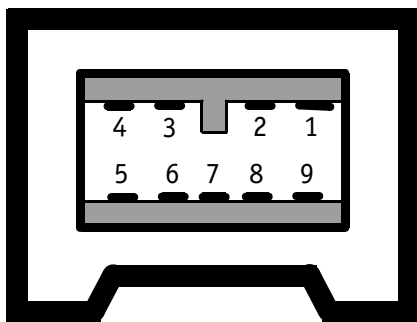

Pin	Signal
1	TPB-
2	TPB+
3	TPA-
4	TPA+
5	TPA (Reference ground)
6	VG (GND)
7	N.C.
8	VP (Power, VCC)
9	TPB (Reference ground)

Figure 25: IEEE1394b connector

### Note



IEEE1394b connectors with screw lock mechanism provide access to the IEEE1394 bus and thus makes it possible to control the camera and output frames.

### www



For more information on cables and on ordering cables online, see:

[www.alliedvision.com/en/support/accessory-documentation](http://www.alliedvision.com/en/support/accessory-documentation)  
[www.alliedvision.com/en/about-us/contact-us](http://www.alliedvision.com/en/about-us/contact-us)

## Camera I/O connections

**Note**

The camera is not intended to be connected to a DC distribution network. The maximum length for I/O cables must not exceed 30 m.

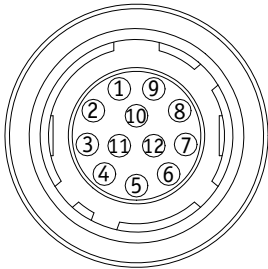

Camera side Hirose HR10-10R-12PA(73) connector					I/O cable color code
Pin	Signal	Direction	Level	Description	
1	External GND		GND for ext. power	External Ground for external power	Blue
2	External Power		8 to 36 VDC	Power supply	Red
3	---	---	---	---	Violet
4	Camera In 1	In	$U_{in}(\text{high}) = 3 \text{ to } 24 \text{ V}$ $U_{in}(\text{low}) = 0 \text{ to } 1.5 \text{ V}$	Camera Input 1 (GPIIn1) default: Trigger	Grey
5	Camera Out 3	Out	Open emitter,	Camera Output 3 (GPOut3) default: Busy	Yellow
6	Camera Out 1	Out	Open emitter	Camera Output 1 (GPOut1) default: IntEna	Green
7	Camera In GND	In	Common GND for inputs	Camera Common Input Ground (In GND)	Brown
8	---	---	---	---	White
9	---	---	---	---	Black
10	Camera Out Power	In	Common VCC for outputs max. 36 VDC	External Power for digital outputs (OutVCC)	Orange
11	---	---	---	---	White/Black
12	Camera Out 2	Out	Open emitter	Camera Output 2 (GPOut2) default: Off	White/Brown

Table 20: Camera I/O connector pin assignment and Guppy PRO I/O cable color coding



**Note**

For cable color and pin out information, see the Allied Vision I/O cable overview:

[www.alliedvision.com/fileadmin/content/documents/products/accessories/cable/datasheet/IO-Cable\\_Overview\\_DataSheet.pdf](http://www.alliedvision.com/fileadmin/content/documents/products/accessories/cable/datasheet/IO-Cable_Overview_DataSheet.pdf)

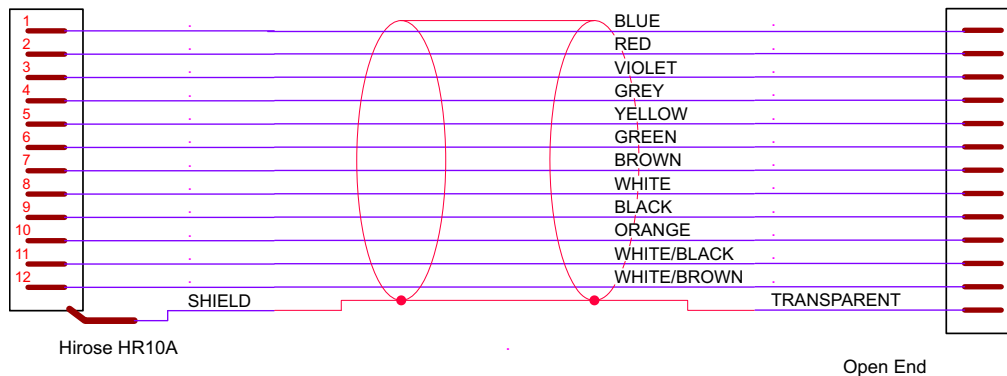

Figure 26: Guppy PRO cable color coding

**Note**

12-pin Hirose I/O cables

The General Purpose I/O port has a Hirose HR10-10R-12PA(73) connector on the camera side. The mating cable connector is:

- Hirose HR10A-10P-12S(73) for soldering
- Hirose HR10A-10P-12SC(73) for crimping

**Note**

GP = General Purpose

For a detailed description of the I/O connector and its operating instructions see the *1394 Installation Manual*, Chapter *Guppy PRO input description*.

Read all Notes and Cautions in the *1394 Installation Manual*, before using the I/O connector.

## Status LEDs

1 status LED bicolor



Figure 27: Position of status LED (example showing green half of LED on)

There is one bicolor LED: showing green or orange (If half **green** and half **red** is on you see an **orange** color).

**RED** means: red half of LED permanent on

**+RED pulsing** means: red half of LED is switched on for a short time. If the red LED is already on, the LED will be switched off.

**GREEN** means: green half of LED permanent on

**+GREEN pulsing** means: green half of LED is switched on for a short time. If the green LED is already on, the LED will be switched off.

### Normal conditions

Event	(GREEN)	(RED)
Camera startup	During startup all LEDs are switched on consecutively to show the startup progress: ( <b>GREEN + RED</b> ) long time then ( <b>GREEN + RED</b> ) short time then <b>GREEN</b> permanent on	
Power on	<b>GREEN</b>	
Bus reset	not available	
Asynchronous traffic	<b>+GREEN pulsing</b>	
Isochronous traffic	<b>+GREEN pulsing</b>	
Waiting for external trigger	<b>GREEN</b>	<b>RED</b>
External trigger event	<b>GREEN</b>	<b>+RED pulsing</b>

Table 21: LEDs showing normal conditions

## Error conditions

Blink codes are used to signal warnings or error states (When S1 and S2 blink together, you see blinking orange):

- S1 means green half of LED
- S2 means red half of LED
- Example: LLC not ready  $\Rightarrow$  S1 (3 blinks) + S2 (5 blinks): 3 orange blinks and afterwards 2 red blinks

Error Code <b>S1</b> $\rightarrow$	1 blink	2 blinks	3 blinks	4 blinks	5 blinks	6 blinks	7 blinks
Error Class <b>S2</b> $\downarrow$							
1 blink	Video mode error	Format7 error 1	Format 7 error 2				
2 blinks	Camera class object	Camera regconst object	Register mapping	Unknown FPGA type ID			
3 blinks	FLASH class object	Platform class object	Platform initialization	Platform firmware set	Platform LLC version		
4 blinks	FPGA boot S1 error	FPGA boot S2 error	FPGA boot S3 error	FPGA boot S4 error	FPGA boot S5 error		FPGA version not supported
5 blinks	Stack setup error	Stack start error	LLC not ready				
6 blinks							
7 blinks							
8 blinks	No valid firmware set available						

Table 22: Error codes

Video mode error: These are error modes according IIDC specification: Vmode\_Error\_Status register (wrong settings of video mode, format, frame rate and ISO settings).

Format 7 error: see Format 7 register description of IIDC specification.

## Control and video data signals

The inputs and outputs of the camera can be configured by software. The different modes are described below.

### Inputs

**Note** For a general description of the inputs and warnings see the *1394 Installation Manual*, Chapter Guppy PRO input description.



The optocoupler inverts all input signals. Inversion of the signal is controlled via the IO\_INP\_CTRL1..2 register (see [table 23](#)).

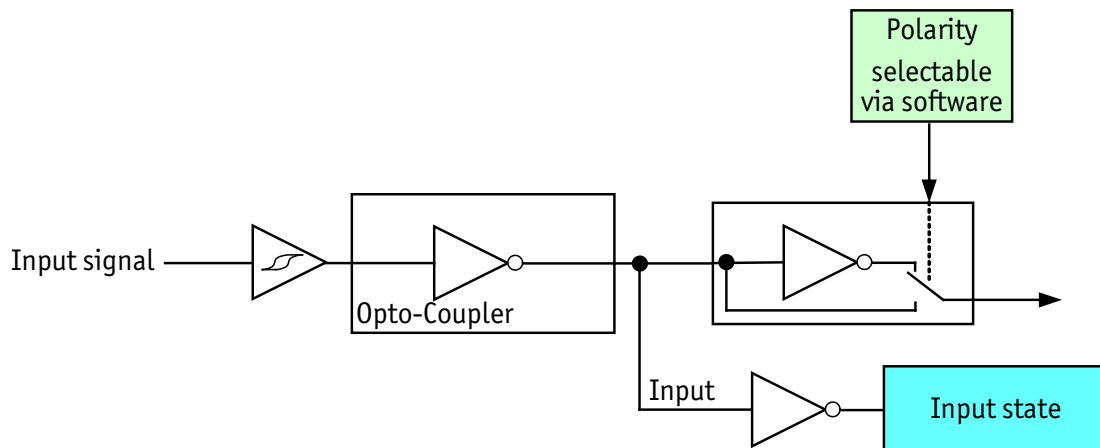

Figure 28: Input block diagram

### Triggers

All inputs configured as triggers are linked by AND. If several inputs are being used as triggers, a high signal must be present on all inputs in order to generate a trigger signal. Each signal can be inverted. The camera must be set to external triggering to trigger image capture by the trigger signal.

## Input/output pin control

All input and output signals running over the camera I/O connector are controlled by an advanced feature register.

Register	Name	Field	Bit	Description
0xF1000300	IO_INP_CTRL1	Presence_Inq	[0]	Indicates presence of this feature (read only)
		---	[1 to 6]	Reserved
		Polarity	[7]	0: Signal not inverted 1: Signal inverted
		---	[8 to 10]	Reserved
		InputMode	[11 to 15]	Mode see <a href="#">table 24</a> :
		---	[16 to 30]	Reserved
		PinState	[31]	RD: Current state of pin

Table 23: Advanced register: Input control

### IO\_INP\_CTRL 1

The Polarity flag determines whether the input is low active (0) or high active (1). The input mode can be seen in the following table. The PinState flag is used to query the current status of the input.

The PinState bit reads the inverting optocoupler status after an internal negation. See [Input block diagram](#) on page 84.

This means that an open input sets the PinState bit to 0. (This is different to Marlin, where an open input sets PinState bit to 1.)

ID	Mode	Default
0x00	Off	
0x01	Reserved	
0x02	Trigger input	Input 1
0x03..0x1F	Reserved	

Table 24: Input routing

#### Note

If you set more than 1 input to function as a trigger input, all trigger inputs are ANDed.



### Trigger delay

Guppy PRO cameras feature various ways to delay image capture based on external trigger.

With IIDC V1.31 there is a standard CSR at Register F0F00534/834h to control a delay up to  $FFFh \times$  time base value.

The following table explains the inquiry register and the meaning of the various bits.

Register	Name	Field	Bit	Description
0xF0F00534	TRIGGER_DELAY_INQUIRY	Presence_Inq	[0]	Indicates presence of this feature (read only)
		Abs_Control_Inq	[1]	Capability of control with absolute value
		---	[2]	Reserved
		One_Push_Inq	[3]	One-push auto mode (controlled automatically by the camera once)
		Readout_Inq	[4]	Capability of reading out the value of this feature
		ON_OFF	[5]	Capability of switching this feature ON and OFF
		Auto_Inq	[6]	Auto mode (controlled automatically by the camera)
		Manual_Inq	[7]	Manual mode (controlled by user)
		Min_Value	[8 to 19]	Minimum value for this feature
		Max_Value	[20 to 31]	Maximum value for this feature

Table 25: Trigger delay inquiry register

Register	Name	Field	Bit	Description
0xF0F00834	TRIGGER_DELAY	Presence_Inq	[0]	Presence of this feature: 0: N/A 1: Available
		Abs_Control	[1]	Absolute value control 0: Control with value in the value field 1: Control with value in the absolute value CSR. If this bit=1 the value in the value field has to be ignored.
		---	[2 to 5]	Reserved
		ON_OFF	[6]	Write ON or OFF this feature Read: Status of the feature ON=1 OFF=0
		---	[7 to 19]	Reserved
		Value	[20 to 31]	Value

Table 26: Trigger Delay CSR

The cameras also have an advanced register which allows even more precise image capture delay after receiving a hardware trigger.

Trigger delay advanced register

Register	Name	Field	Bit	Description
0xF1000400	TRIGGER_DELAY	Presence_Inq	[0]	Indicates presence of this feature (read only)
		---	[1 to 5]	Reserved
		ON_OFF	[6]	Trigger delay on/off
		---	[7 to 10]	Reserved
		DelayTime	[11 to 31]	Delay time in $\mu$ s

Table 27: Trigger delay advanced CSR

The advanced register allows the start of the integration to be delayed by max.  $2^{21}$   $\mu$ s, which is max. 2.1 s after a trigger edge was detected.

**Note**



- Switching trigger delay to ON also switches external Trigger\_Mode\_0 to ON.
- This feature works with external Trigger\_Mode\_0 only.

## Outputs

### Note



For a general description of the outputs and warnings see the *1394 Installation Manual*, Chapter Guppy PRO output description.

Output features are configured by software. Any signal can be placed on any output. The main features of output signals are described below.

Signal	Description
IntEna (Integration Enable) signal	This signal displays the time in which exposure was made. By using a register this output can be delayed by up to 1.05 seconds.
Fval (Frame valid) signal	This feature signals readout from the sensor. This signal follows IntEna.
Busy signal	This signal appears when: <ul style="list-style-type: none"> <li>the exposure is being made or</li> <li>the sensor is being read out or</li> <li>data transmission is active.</li> </ul> The camera is busy.
PulseWidthMod signal (pulse-width modulation)	Each output has pulse-width modulation (PWM) capabilities, which can be used for motorized speed control or autofocus control. See <a href="#">Pulse-width modulation</a> on page 91.
WaitingForTrigger signal	This signal is available and useful for the outputs in Trigger Edge Mode. (In level mode it is available but useless, because exposure time is unknown. (Signal always =0)) In edge mode it is useful to know if the camera can accept a new trigger (without over-triggering). See <a href="#">table 30:</a> and <a href="#">figure 30:</a> .

Table 28: Output signals

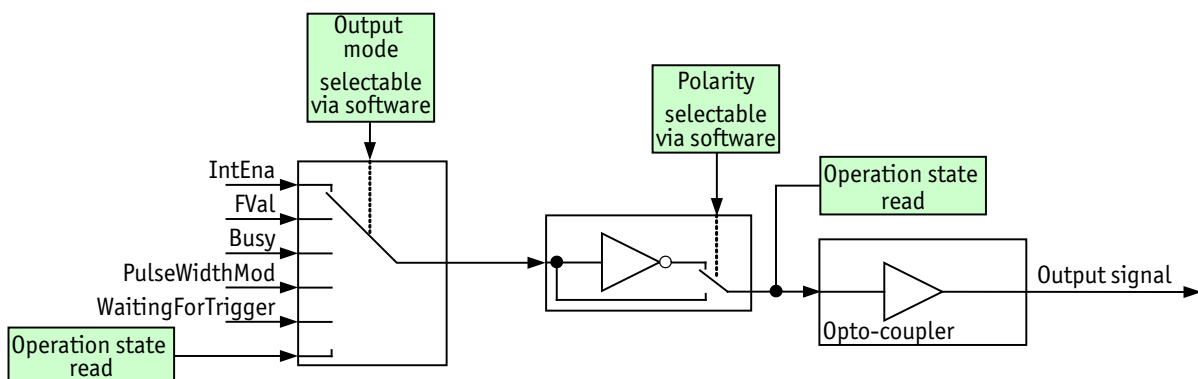

Figure 29: Output block diagram



### IO\_OUTP\_CTRL 1-3

The outputs (Output mode, Polarity) are controlled via 3 advanced feature registers (see [table 29](#)).

The Polarity field determines whether the output is inverted or not. The output mode can be viewed in the table below. The current status of the output can be queried and set via the PinState.

It is possible to read back the status of an output pin regardless of the output mode. This allows for example the host computer to determine if the camera is busy by simply polling the BUSY output.

#### Note

Outputs in Direct Mode:



For correct functionality the Polarity should always be set to 0 (SmartView: Trig/IO tab, Invert=No).

Register	Name	Field	Bit	Description
0xF1000320	IO_OUTP_CTRL1	Presence_Inq	[0]	Indicates presence of this feature (read only)
		PWMCapable	[1]	All Guppy PRO cameras: Indicates if an output pin supports the PWM feature. See <a href="#">table 31</a> .
		---	[2 to 6]	Reserved
		Polarity	[7]	0: Signal not inverted 1: Signal inverted
		---	[8 to 10]	Reserved
		Output mode	[11 to 15]	Mode see <a href="#">table 30</a> .
		---	[16 to 30]	Reserved
		PinState	[31]	RD: Current state of pin WR: New state of pin
0xF1000324	IO_OUTP_CTRL2	Same as IO_OUTP_CTRL1		
0xF1000328	IO_OUTP_CTRL3	Same as IO_OUTP_CTRL1		

Table 29: Advanced register: Output control

**Output modes**

ID	Mode	Default / description
0x00	Off	
0x01	Output state follows PinState bit	Using this mode, the Polarity bit has to be set to 0 (not inverted). This is necessary for an error free display of the output status.
0x02	Integration enable	Output 1
0x03	Reserved	
0x04	Reserved	
0x05	Reserved	
0x06	FrameValid	
0x07	Busy	Output 2
0x08	Follow corresponding input (Inp1 → Out1, Inp2 → Out2)	
0x09	PWM (=pulse-width modulation)	Guppy PRO housing models
0x0A	WaitingForTrigger	Only in Trigger Edge Mode. All other Mode = 0 WaitingForTrigger is useful to know if a new trigger will be accepted.
0x0B..0x1F	Reserved	

Table 30: Output routing

PinState 0 switches off the output transistor and produces a low level over the resistor connected from the output to ground. The following diagram illustrates the dependencies of the various output signals.

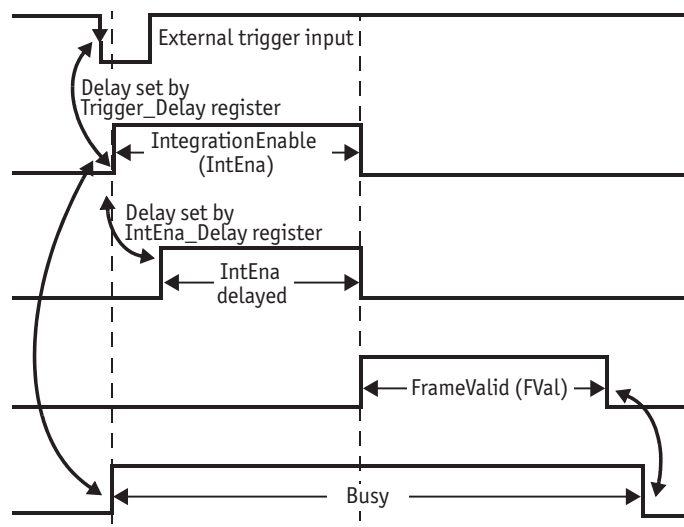

Figure 30: Output impulse diagram

**Note** The signals can be inverted.



**Caution** Firing a new trigger while IntEna is still active can result in missing image.



**Note**



- Note that trigger delay in fact delays the image capture whereas the IntEna\_Delay only delays the leading edge of the IntEna output signal but does not delay the image capture.
- As mentioned before, it is possible to set the outputs by software. Doing so, the achievable maximum frequency is strongly dependent on individual software capabilities. As a rule of thumb, the camera itself will limit the toggle frequency to not more than 700 Hz.

## Pulse-width modulation

The 1 input and 3 outputs are independent. Each output has pulse-width modulation (PWM) capabilities, which can be used (with additional external electronics) for motorized speed control or autofocus control.

Period (in  $\mu\text{s}$ ) and pulse width (in  $\mu\text{s}$ ) are adjustable via the following registers (see also examples in [PWM: Examples in practice](#) on page 93).

Register	Name	Field	Bit	Description
0xF1000800	IO_OUTP_PWM1	Presence_Inq	[0]	Indicates presence of this feature (read only)
		---	[1]	Reserved
		---	[2 to 3]	Reserved
		MinPeriod	[4 to 19]	Minimum PWM period in $\mu\text{s}$ (read only)
		---	[20 to 27]	Reserved
		---	[28 to 31]	Reserved
0xF1000804		PulseWidth	[0 to 15]	PWM pulse width in $\mu\text{s}$
		Period	[16 to 31]	PWM period in $\mu\text{s}$

Table 31: PWM configuration registers

Register	Name	Field	Bit	Description
0xF1000808	IO_OUTP_PWM2	Same as IO_OUTP_PWM1		
0xF100080C				
0xF1000810	IO_OUTP_PWM3	Same as IO_OUTP_PWM1		
0xF1000814				
0xF1000818	IO_OUTP_PWM4	Same as IO_OUTP_PWM1		
0xF100081C				

Table 31: PWM configuration registers (continued)

To enable the PWM feature select output mode 0x09. Control the signal state via the PulseWidth and Period fields (all times in microseconds ( $\mu\text{s}$ )).

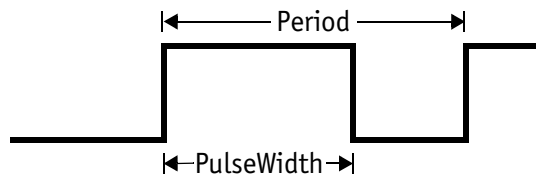

Figure 31: PulseWidth and Period definition

**Note** Note the following conditions:



- PulseWidth < Period
- Period  $\geq$  MinPeriod

### PWM: minimum and maximum periods and frequencies

In the following formulas you find the minimum and maximum periods and frequencies for the pulse-width modulation (PWM).

$$\text{period}_{\min} = 3 \mu\text{s}$$

$$\Rightarrow \text{frequency}_{\max} = \frac{1}{\text{period}_{\min}} = \frac{1}{3 \mu\text{s}} = 333.33 \text{ kHz}$$

$$\text{frequency}_{\min} = \frac{1}{2^{16} \times 10^{-6} \text{ s}} = 15.26 \text{ Hz}$$

$$\Rightarrow \text{period}_{\max} = \frac{1}{\text{frequency}_{\min}} = 2^{16} \mu\text{s}$$

Formula 1: Minimum and maximum period and frequency

### PWM: Examples in practice

In this chapter we give you two examples, how to write values in the PWM registers. All values have to be written in microseconds ( $\mu\text{s}$ ) in the PWM registers; therefore, remember always the factor  $10^{-6}\text{s}$ .

Example 1:

Set PWM with 1kHz at 30% pulse width.

$$\text{RegPeriod} = \frac{1}{\text{frequency} \times 10^{-6} \text{ s}} = \frac{1}{1\text{kHz} \times 10^{-6} \text{ s}} = 1000$$

$$\text{RegPulseWidth} = \text{RegPeriod} \times 30\% = 1000 \times 30\% = 300$$

*Formula 2: PWM example 1*

Example 2:

Set PWM with 250 Hz at 12% pulse width.

$$\text{RegPeriod} = \frac{1}{\text{frequency} \times 10^{-6} \text{ s}} = \frac{1}{250\text{Hz} \times 10^{-6} \text{ s}} = 4000$$

$$\text{RegPulseWidth} = \text{RegPeriod} \times 12\% = 4000 \times 12\% = 480$$

*Formula 3: PWM example 2*

## Pixel data

Pixel data are transmitted as isochronous data packets in accordance with the 1394 interface described in IIDC V1.31. The first packet of a frame is identified by the 1 in the sync bit (sy) of the packet header.

0 to 7	8 to 15	16 to 23	24 to 31
data_length		tg	channel
		tCode	sy
header_CRC			
Video data payload			
data_CRC			

**sync bit**  
↓

*Table 32: Isochronous data block packet format. Source: IIDC V1.31*

Field	Description
data_length	Number of bytes in the data field
tg	Tag field shall be set to zero
channel	Isochronous channel number, as programmed in the iso_channel field of the cam_sta_ctrl register
tCode	Transaction code shall be set to the isochronous data block packet tCode
sy	Synchronization value (sync bit)  This is one single bit. It indicates the start of a new frame. It shall be set to 0001h on the first isochronous data block of a frame, and shall be set to zero on all other isochronous blocks
Video data payload	Shall contain the digital video information

Table 33: Description of data block packet format

- The video data for each pixel are output in either 8-bit or 14-bit format (Packed 12-Bit Mode: 12-bit format).
- Each pixel has a range of 256 or 16384 (Packed 12-Bit Mode: 4096) shades of gray.
- The digital value 0 is black and 255 or 16383 (Packed 12-Bit Mode: 4095) is white. In 16-bit mode the data output is MSB aligned.

## Description of video data formats

The following tables provide a description of the video data format for the different modes. (Source: IIDC V1.31; packed 12-bit mode: Allied Vision)

<YUV8 (4:2:2) format>

Each component has 8-bit data.

<YUV8 (4:2:2) format>			
$U_{(K+0)}$	$Y_{(K+0)}$	$V_{(K+0)}$	$Y_{(K+1)}$
$U_{(K+2)}$	$Y_{(K+2)}$	$V_{(K+2)}$	$Y_{(K+3)}$
$U_{(K+4)}$	$Y_{(K+4)}$	$V_{(K+4)}$	$Y_{(K+5)}$
$U_{(K+Pn-6)}$	$Y_{(K+Pn-6)}$	$V_{(K+Pn-6)}$	$Y_{(K+Pn-5)}$
$U_{(K+Pn-4)}$	$Y_{(K+Pn-4)}$	$V_{(K+Pn-4)}$	$Y_{(K+Pn-3)}$
$U_{(K+Pn-2)}$	$Y_{(K+Pn-2)}$	$V_{(K+Pn-2)}$	$Y_{(K+Pn-1)}$

Table 34: YUV8 (4:2:2) format: Source: IIDC V1.31

<YUV8 (4:1:1 format)>

Each component has 8-bit data.

<b>&lt;YUV8 (4:1:1) format&gt;</b>			
$U_{(K+0)}$	$Y_{(K+0)}$	$Y_{(K+1)}$	$V_{(K+0)}$
$Y_{(K+2)}$	$Y_{(K+3)}$	$U_{(K+4)}$	$Y_{(K+4)}$
$Y_{(K+5)}$	$V_{(K+4)}$	$Y_{(K+6)}$	$Y_{(K+7)}$
$U_{(K+Pn-8)}$	$Y_{(K+Pn-8)}$	$Y_{(K+Pn-7)}$	$V_{(K+Pn-8)}$
$Y_{(K+Pn-6)}$	$Y_{(K+Pn-5)}$	$U_{(K+Pn-4)}$	$Y_{(K+Pn-4)}$
$Y_{(K+Pn-3)}$	$V_{(K+Pn-4)}$	$Y_{(K+Pn-2)}$	$Y_{(K+Pn-1)}$

Table 35: YUV8 (4:1:1) format: Source: IIDC V1.31

<Y (Mono8/Raw8) format>

Y component has 8-bit data.

<b>&lt;Y (Mono8/Raw8) format&gt;</b>			
$Y_{(K+0)}$	$Y_{(K+1)}$	$Y_{(K+2)}$	$Y_{(K+3)}$
$Y_{(K+4)}$	$Y_{(K+5)}$	$Y_{(K+6)}$	$Y_{(K+7)}$
$Y_{(K+Pn-8)}$	$Y_{(K+Pn-7)}$	$Y_{(K+Pn-6)}$	$Y_{(K+Pn-5)}$
$Y_{(K+Pn-4)}$	$Y_{(K+Pn-3)}$	$Y_{(K+Pn-2)}$	$Y_{(K+Pn-1)}$

Table 36: Y (Mono8) format: Source: IIDC V1.31 / Y (Raw8) format: Allied Vision

<Y (Mono16/Raw16) format>

Y component has 16-bit data.

<b>&lt;Y (Mono16) format&gt;</b>	
High byte	Low byte
$Y_{(K+0)}$	$Y_{(K+1)}$
$Y_{(K+2)}$	$Y_{(K+3)}$
$Y_{(K+Pn-4)}$	$Y_{(K+Pn-3)}$
$Y_{(K+Pn-2)}$	$Y_{(K+Pn-1)}$

Table 37: Y (Mono16) format: Source: IIDC V1.31

<Y (Mono12/Raw12) format>

<b>&lt;Y (Mono12) format&gt;</b>			
$Y_{(K+0)}$ [11..4]	$Y_{(K+1)}$ [3..0] $Y_{(K+0)}$ [3..0]	$Y_{(K+1)}$ [11..4]	$Y_{(K+2)}$ [11..4]
$Y_{(K+3)}$ [3..0] $Y_{(K+2)}$ [3..0]	$Y_{(K+3)}$ [11..4]	$Y_{(K+4)}$ [11..4]	$Y_{(K+5)}$ [3..0] $Y_{(K+4)}$ [3..0]
$Y_{(K+5)}$ [11..4]	$Y_{(K+6)}$ [11..4]	$Y_{(K+7)}$ [3..0] $Y_{(K+6)}$ [3..0]	$Y_{(K+7)}$ [11..4]

Table 38: Packed 12-Bit Mode (mono and raw) Y12 format (Allied Vision)

<Y(Mono8/Raw8), RGB8>

Each component (Y, R, G, B) has 8-bit data. The data type is *Unsigned Char*.

<b>Y, R, G, B</b>	<b>Signal level (decimal)</b>	<b>Data (hexadecimal)</b>
Highest	255	0xFF
	254	0xFE
	.	.
	.	.
	1	0x01
Lowest	0	0x00

Table 39: Data structure of Mono8, RGB8; Source: IIDC V1.31 / Y(Mono8/Raw8) format: Allied Vision



<YUV8>

Each component (Y, U, V) has 8-bit data. The Y component is the same as in the above table.

U, V	Signal level (decimal)	Data (hexadecimal)
Highest (+)	127	0xFF
	126	0xFE
	.	.
Lowest	1	0x81
	0	0x80
	-1	0x7F
Highest (-)	-127	0x01
	-128	0x00

Table 40: Data structure of YUV8; Source: IIDC V1.31

<Y(Mono16)>

Y component has 16-bit data. The data type is *Unsigned Short (big endian)*.

Y	Signal level (decimal)	Data (hexadecimal)
Highest	65535	0xFFFF
	65534	0xFFFE
	.	.
Lowest	1	0x0001
	0	0x0000

Table 41: Data structure of Y(Mono16); Source: IIDC V1.31

<Y(Mono12)>

Y component has 12-bit data. The data type is *unsigned*.

Y	Signal level (decimal)	Data (hexadecimal)
Highest	4095	0x0FFF
	4094	0x0FFE
	.	.
Lowest	1	0x0001
	0	0x0000

Table 42: Data structure of Packed 12-Bit Mode (mono and raw) (Allied Vision)

# Description of the data path

## Block diagrams of Guppy PRO models

The following diagrams illustrate the data flow and the bit resolution of image data after being read from the CCD sensor chip in the camera. The individual blocks are described in more detail in the following paragraphs. For sensor data see [Specifications](#) on page 52.

### Monochrome models

CMOS: the following functions are integrated in sensor:  
Binning, sub-sampling, horizontal masking

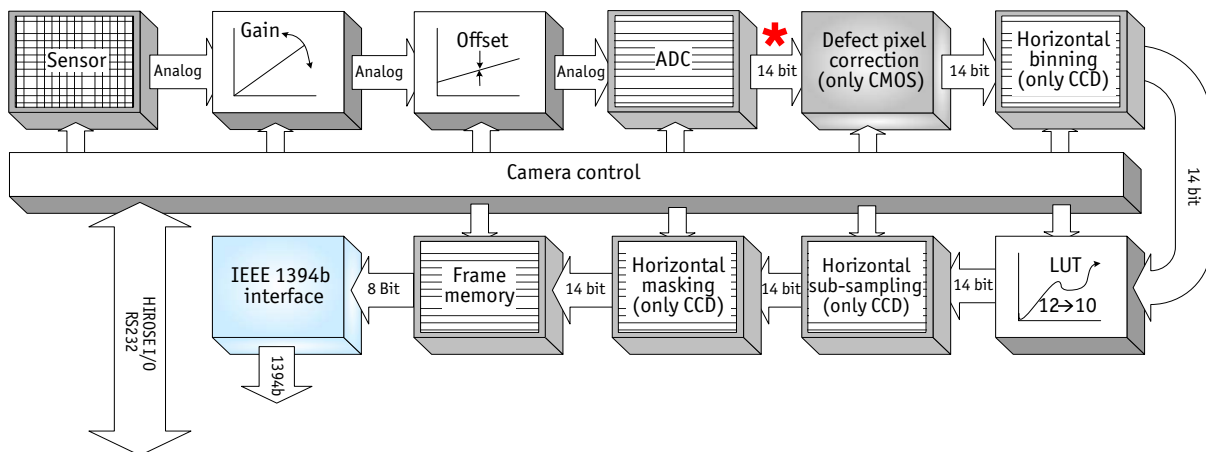

\* Some Guppy PRO models deliver 12-bit only.

Figure 32: Block diagram monochrome camera

Setting LUT = OFF effectively makes full use of the 14-bit by bypassing the LUT circuitry; setting LUT = ON means that the most significant 12-bit of the 14-bit are used and further down converted to 10-bit. For models with 12-bit ADC: the most significant 10-bit of the 12-bit are used.

## Color models

CMOS: the following functions are integrated in sensor:  
Sub-sampling, horizontal masking

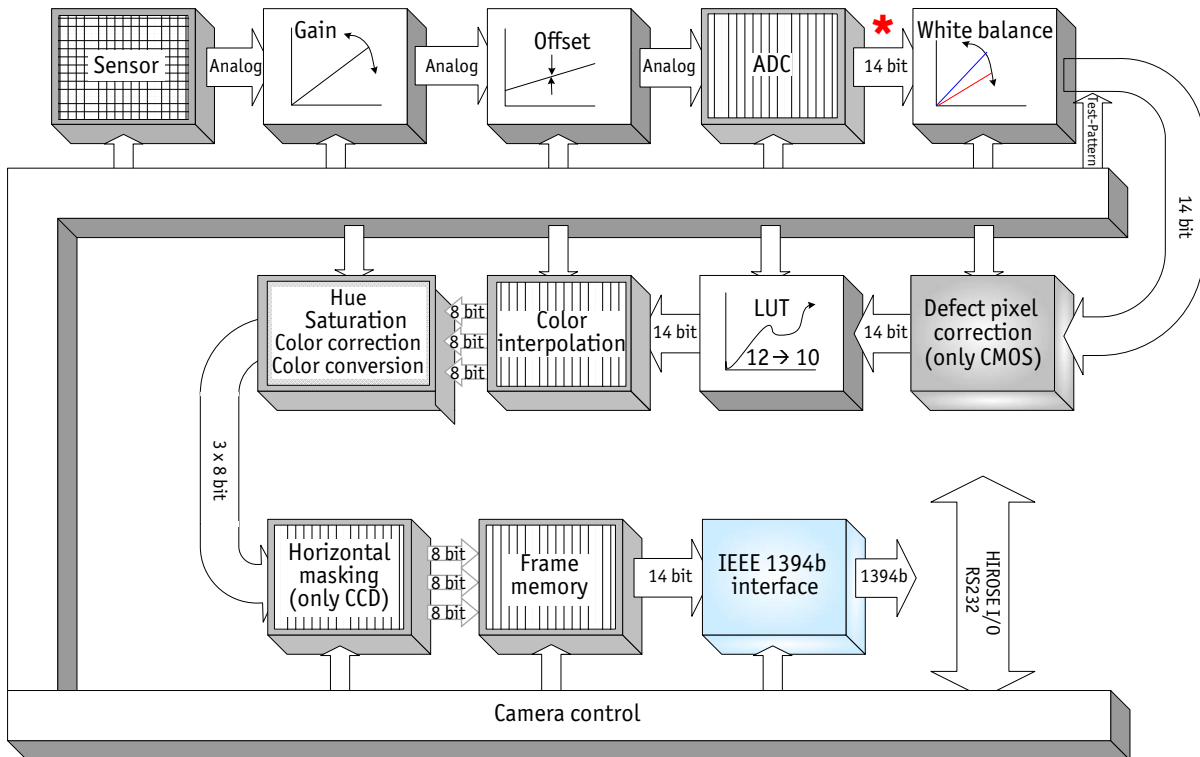

\* Some Guppy PRO models deliver 12-bit only.

Figure 33: Block diagram color camera

Setting LUT = OFF effectively makes full use of the 14-bit by bypassing the LUT circuitry; setting LUT = ON means that the most significant 12-bit of the 14-bit are used and further down converted to 10-bit. For models with 12-bit ADC: the most significant 10-bit of the 12-bit are used.

## White balance

There are two types of white balance:

- **one-push white balance:** white balance is done only once (not continuously)
- **auto white balance (AWB):** continuously optimizes the color characteristics of the image

Guppy PRO color models have both **one-push white balance** and **auto white balance**.

White balance is applied so that non-colored image parts are displayed non-colored.

From the user's point, the white balance settings are made in register 80Ch of IIDC V1.31. This register is described in more detail below.

Register	Name	Field	Bit	Description
0xF0F0080C	WHITE_BALANCE	Presence_Inq	[0]	Presence of this feature: 0: N/A 1: Available
		Abs_Control	[1]	Absolute value control 0: Control with value in the <b>Value</b> field 1: Control with value in the <b>Absolute</b> value CSR If this bit=1, the value in the <b>Value</b> field will be ignored.
		---	[2 to 4]	Reserved
		One_Push	[5]	Write 1: begin to work (self-cleared after operation) Read: 1: in operation 0: not in operation If A_M_Mode = 1, this bit will be ignored.
		ON_OFF	[6]	Write: ON or OFF this feature Read: read a status 0: OFF 1: ON
		A_M_MODE	[7]	Write: set mode Read: read current mode 0: MANUAL 1: AUTO
		U/B_Value	[8 to 19]	U/B value This field is ignored when writing the value in Auto or OFF mode. If readout capability is not available, reading this field has no meaning.
		V/R_Value	[20 to 31]	V/R value This field is ignored when writing the value in Auto or OFF mode. If readout capability is not available, reading this field has no meaning.

Table 43: White balance register

The values in the U/B\_Value field produce changes from green to blue; the V/R\_Value field from green to red as illustrated below.

**Note** While lowering both U/B and V/R registers from 284 towards 0, the lower one of the two effectively controls the green gain.

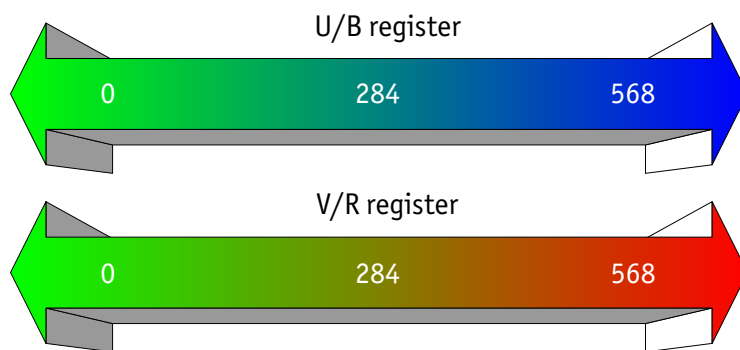

Figure 34: U/V slider range

Type	Range	Range in dB
Guppy PRO color models	0 to 568	± 10 dB

Table 44: U/V slider range for Guppy PRO models

The increment length is ~0.0353 dB/step.

## One-push white balance

**Note** Configuration



To configure this feature in control and status register (CSR): See [table 43 on page 100](#).

The camera automatically generates frames, based on the current settings of all registers (GAIN, OFFSET, SHUTTER, etc.).

For white balance, in total 9 frames are processed. For the white balance algorithm the whole image or a subset of it is used. The R-G-B component values of the samples are added and are used as actual values for the **one-push white balance**.

This feature uses the assumption that the R-G-B component sums of the samples shall be equal; i.e., it assumes that the average of the sampled grid pixels is to be monochrome.

**Note** The following ancillary conditions should be observed for successful white balance:



- There are no stringent or special requirements on the image content, it requires only the presence of monochrome pixels in the image.

If the image capture is active (e.g. **IsoEnable** set in register 614h), the frames used by the camera for white balance are also output on the 1394 bus. Any previously active image capture is restarted after the completion of white balance.

The following flow diagram illustrates the **one-push white balance** sequence.

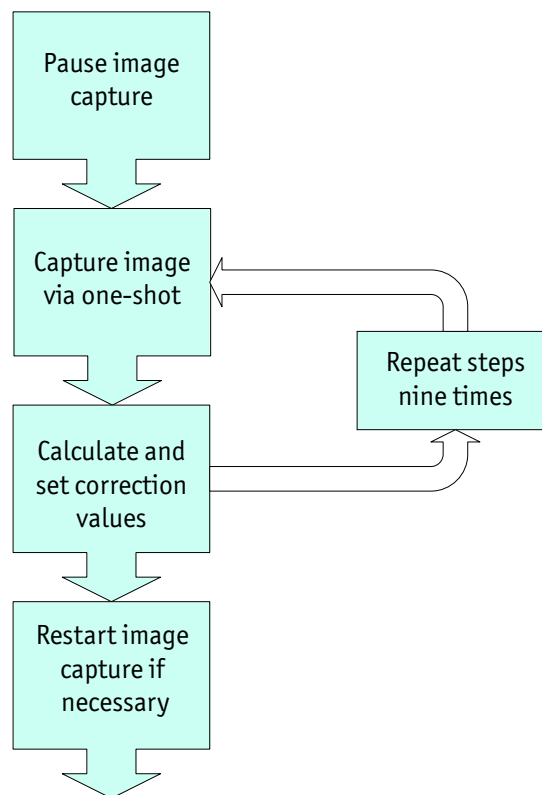

*Figure 35: One-push white balance sequence*

Finally, the calculated correction values can be read from the WHITE\_BALANCE register 80Ch.

### Auto white balance (AWB)

The **auto white balance** feature continuously optimizes the color characteristics of the image. For the white balance algorithm the whole image or a subset of it is used.

Auto white balance can also be enabled by using an external trigger. However, if there is a pause of >10 seconds between capturing individual frames this process is aborted.

**Note** The following ancillary conditions should be observed for successful white balance:



- There are no stringent or special requirements on the image content, it requires only the presence of equally weighted RGB pixels in the image.
- **Auto white balance** can be started both during active image capture and when the camera is in idle state.

**Note** Configuration



To set position and size of the control area (Auto\_Function\_AOI) in an advanced register, see [table 136: on page 242](#).

AUTOFNC\_AOI affects the auto shutter, auto gain and auto white balance features and is independent of the Format\_7 AOI settings. If this feature is switched off the work area position and size will follow the current active image size.

Within this area, the R-G-B component values of the samples are added and used as actual values for the feedback. The following drawing illustrates the AUTOFNC\_AOI settings in greater detail.

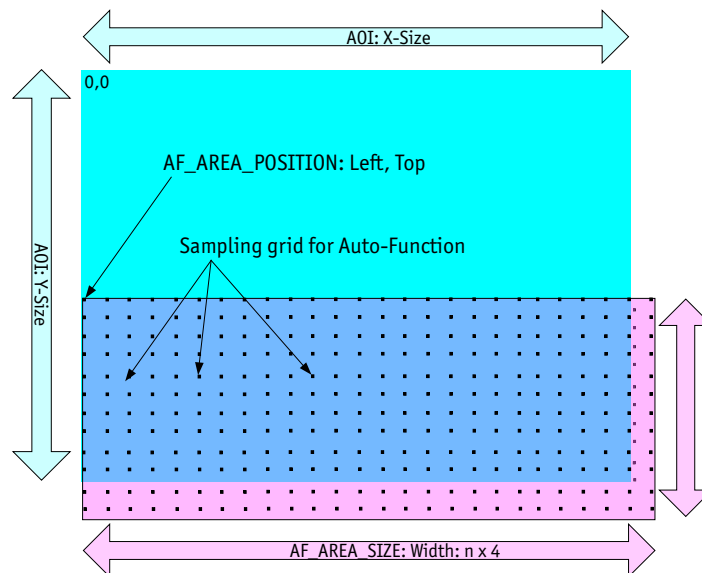

Figure 36: AUTOFNC\_AOI positioning

The algorithm is based on the assumption that the R-G-B component sums of the samples are equal, i.e., it assumes that the mean of the sampled grid pixels is to be monochrome.

## Auto shutter

In combination with auto white balance, Guppy PRO models are equipped with **auto shutter** feature. When enabled, the auto shutter adjusts the shutter within the default shutter limits or within those set in advanced register F1000360h in order to reach the reference brightness set in auto exposure register.

**Note** Target gray level parameter in **SmartView** corresponds to **Auto\_exposure** register 0xF0F00804 (IIDC).



Increasing the auto exposure value increases the average brightness in the image and vice versa.

The applied algorithm uses a proportional plus integral controller (PI controller) to achieve minimum delay with minimum overshoot.

To configure this feature in control and status register (CSR):

Register	Name	Field	Bit	Description
0xF0F0081C	SHUTTER	Presence_Inq	[0]	Presence of this feature: 0: N/A 1: Available
		Abs_Control	[1]	Absolute value control 0: Control with value in the <b>Value</b> field 1: Control with value in the <b>Absolute</b> value CSR If this bit=1, the value in the <b>Value</b> field will be ignored.
		---	[2 to 4]	Reserved
		One_Push	[5]	Write 1: begin to work (self-cleared after operation) Read: 1: in operation 0: not in operation If A_M_Mode = 1, this bit will be ignored.
		ON_OFF	[6]	Write: ON or OFF this feature Read: read a status 0: OFF 1: ON

Table 45: CSR: Shutter



Register	Name	Field	Bit	Description
0xF0F0081C	SHUTTER	A_M_MODE	[7]	Write: set mode Read: read current mode 0: MANUAL 1: AUTO
		---	[8 to 19]	Reserved
		Value	[20 to 31]	Read/Write Value  This field is ignored when writing the value in Auto or OFF mode. If readout capability is not available, reading this field has no meaning.

Table 45: CSR: Shutter (continued)

**Note** Configuration



To configure this feature in an advanced register: See [table 134: on page 240](#).

## Auto gain

All Guppy PRO models are equipped with **auto gain** feature.

**Note** Configuration



To configure this feature in an advanced register, see [table 135: on page 242](#).

When enabled auto gain adjusts the gain within the default gain limits or within the limits set in advanced register F1000370h in order to reach the brightness set in auto exposure register as reference.

Increasing the auto exposure value (aka **target gray value**) increases the average brightness in the image and vice versa.

The applied algorithm uses a proportional plus integral controller (PI controller) to achieve minimum delay with zero overshoot.

The following tables show the gain and auto exposure CSR.

Register	Name	Field	Bit	Description
0xF0F00820	GAIN	Presence_Inq	[0]	Presence of this feature: 0: N/A 1: Available
		Abs_Control	[1]	Absolute value control 0: Control with value in the value field 1: Control with value in the absolute value CSR If this bit=1 the value in the value field has to be ignored.
		---	[2 to 4]	Reserved
		One_Push	[5]	Write: Set bit high to start Read: Status of the feature: Bit high: WIP Bit low: Ready
		ON_OFF	[6]	Write: ON or OFF this feature Read: read a status 0: OFF 1: ON
		A_M_MODE	[7]	Write: set mode Read: read current mode 0: MANUAL 1: AUTO
		---	[8 to 19]	Reserved
		Value	[20 to 31]	Read/Write Value  This field is ignored when writing the value in Auto or OFF mode.  If readout capability is not available, reading this field has no meaning.

Table 46: CSR: Gain

Register	Name	Field	Bit	Description
0xF0F00804	AUTO_EXPOSURE	Presence_Inq	[0]	Presence of this feature: 0: N/A 1: Available
		Abs_Control	[1]	Absolute value control 0: Control with value in the value field 1: Control with value in the absolute value CSR If this bit=1 the value in the value field has to be ignored.
		---	[2 to 4]	Reserved
		One_Push	[5]	Write: Set bit high to star Read: Status of the feature:  Bit high: WIP Bit low: Ready
		ON_OFF	[6]	Write: ON or OFF this feature  Read: read a status  0: OFF 1: ON
		A_M_MODE	[7]	Write: set mode Read: read current mode  0: MANUAL 1: AUTO
		---	[8 to 19]	Reserved
		Value	[20 to 31]	Read/Write Value  This field is ignored when writing the value in Auto or OFF mode.  If readout capability is not available, reading this field has no meaning.

Table 47: CSR: Auto Exposure

**Note**

**Configuration**

To configure this feature in an advanced register, see [table 135: on page 242](#).

**Note**

- Values can only be changed within the limits of gain CSR.
- Changes in auto exposure register only have an effect when auto gain is active.
- Auto exposure limits are 50 to 205. (SmartView→Ctrl1 tab: Target gray level)

## Manual gain

Guppy PRO models are equipped with a gain setting, allowing the gain to be manually adjusted on the fly by means of a simple command register write.

The following ranges can be used when manually setting the gain for the analog video signal:

Type	Range	Range in dB	Increment length
Guppy PRO CCD models	0 to 680	0 to 24.4 dB	~0.0359 dB/step
Guppy PRO F-503 (CMOS camera)	8 to 32	0 to 12.04 dB	~0.125/step (1.02- 0.28 dB/step)
	33 to 48	12.57 to 18.06 dB	~0.5/step (0.53- 0.28 dB/step)

Table 48: Manual gain range for Guppy PRO models

**Note**

- Setting the gain does not change the offset (black value)
- A higher gain produces greater image noise. This reduces image quality. For this reason, try first to increase the brightness, using the aperture of the camera optics and/or longer shutter settings.

## Brightness (black level or offset)

It is possible to set the black level in the camera within the following ranges:

0 to +16 gray values (@ 8 bit)

Increments are in 1/64 LSB (@ 8 bit)

**Note**

Setting the gain does not change the offset (black value).



The IIDC register brightness at offset 800h is used for this purpose.

The following table shows the BRIGHTNESS register.

Register	Name	Field	Bit	Description
0xF0F00800	BRIGHTNESS	Presence_Inq	[0]	Presence of this feature: 0: N/A 1: Available
		Abs_Control	[1]	Absolute value control 0: Control with value in the value field 1: Control with value in the absolute value CSR If this bit= 1 the value in the value field has to be ignored
		---	[2 to 4]	Reserved
		One_Push	[5]	Write: Set bit high to start Read: Status of the feature:  Bit high: WIP Bit low: Ready
		ON_OFF	[6]	Write: ON or OFF this feature  Read: read a status  0: OFF 1: ON
		A_M_MODE	[7]	Write: set mode Read: read current mode  0: MANUAL 1: AUTO
		---	[8 to 19]	Reserved
		Value	[20 to 31]	Read/Write Value; this field is ignored when writing the value in Auto or OFF mode; if readout capability is not available reading this field has no meaning.

Table 49: CSR: Brightness

## Mirror function (Guppy PRO F-503B, F-503C)

Guppy PRO F-503 models are equipped with a mirror function, which is built directly into the sensor. The mirror is centered to the current FOV center and can be combined with all image manipulation functions, like **binning**.

This function is especially useful when the camera is looking at objects with the help of a mirror or in certain microscopy applications.

- With Guppy PRO F-503B, horizontal and vertical mirror is possible.
- With Guppy PRO F-503C, only horizontal mirror is possible.

**Note** Configuration



To configure this feature in an advanced register, see [table 139: on page 245](#).

**Note**



The use of the mirror function with color models and image output in RAW format has implications on the Bayer-ordering of the colors.

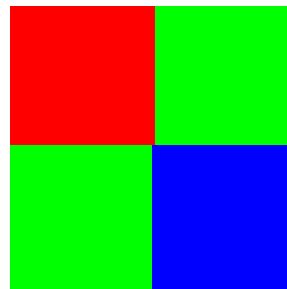
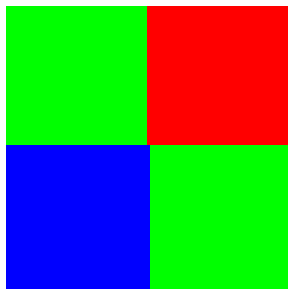

Mirror OFF: G-R-B-G (Guppy PRO F-503C)    Horizontal mirror ON: R-G-G-B (Guppy PRO F- 503C)

*Figure 37: Mirror and Bayer order*

**Note**

During switchover one image may be temporarily corrupted.



## Look-up table (LUT) and gamma function

The Guppy PRO camera provides **one** user-defined look-up table (LUT). The use of this LUT allows any function (in the form  $\text{Output} = F(\text{Input})$ ) to be stored in the camera's RAM and to be applied on the individual pixels of an image at runtime.

The address lines of the RAM are connected to the incoming digital data, these in turn point to the values of functions which are calculated offline, e.g. with a spreadsheet program.

This function needs to be loaded into the camera's RAM before use.

One example of using an LUT is the gamma LUT:

There is one gamma LUT (gamma= 0.45)

$$\text{Output} = (\text{Input})^{0.45}$$

or with normalized values:

$$\text{Output}/1023 = (\text{Input}/4095)^{0.45}$$

This gamma LUT is used with all Guppy PRO models.

Gamma is known as compensation for the nonlinear brightness response of many displays e.g. CRT monitors. The look-up table converts the incoming **12 bit** from the digitizer to outgoing **10 bit**.

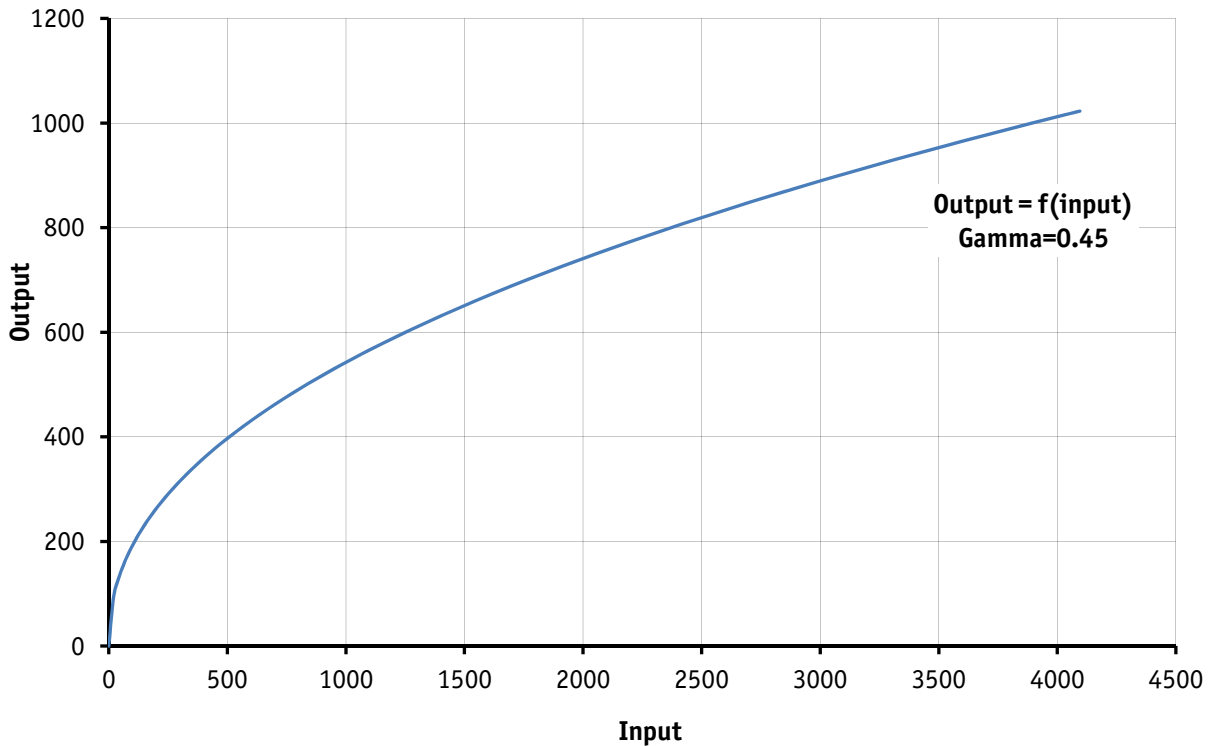

Figure 38: LUT with gamma= 0.45

**Note**



- The input value is the most significant 12-bit value from the digitizer.
- Gamma 1 (gamma= 0.45) switches on the LUT. After overriding the LUT with a user defined content, gamma functionality is no longer available until the next full initialization of the camera.
- LUT content is volatile if you do not use the user profiles to save the LUT.

**Loading an LUT into the camera**

Loading the LUT is carried out through the data exchange buffer called GPDATA\_BUFFER. As this buffer can hold a maximum of 2 KB, and a complete LUT at 4096 × 10-bit is 5 KB, programming cannot take place in a one block

write step because the size of an LUT is larger than Gpdata\_BUFFER. Therefore, input must be handled in several steps. The flow diagram below shows the sequence required to load data into the camera.

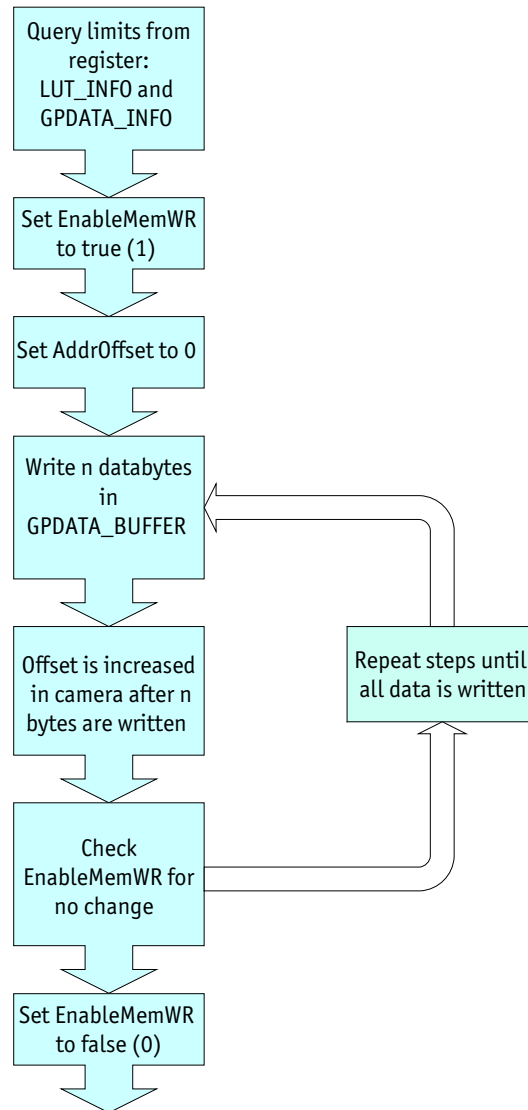

Figure 39: Loading an LUT

#### Note



#### Configuration

- To configure this feature in an advanced register, see [table 131: on page 236](#).
- For information on Gpdata\_BUFFER, see [Gpdata\\_BUFFER](#) on page 254.



## Defect pixel correction (Guppy PRO F-503B, F-503C)

The mechanisms of defect pixel correction are explained in the following drawings. All examples are done in Format\_7 Mode\_0 (full resolution).

The first two examples are explained for monochrome models, the third and fourth example are explained for color models.

The X marks a defect pixel.

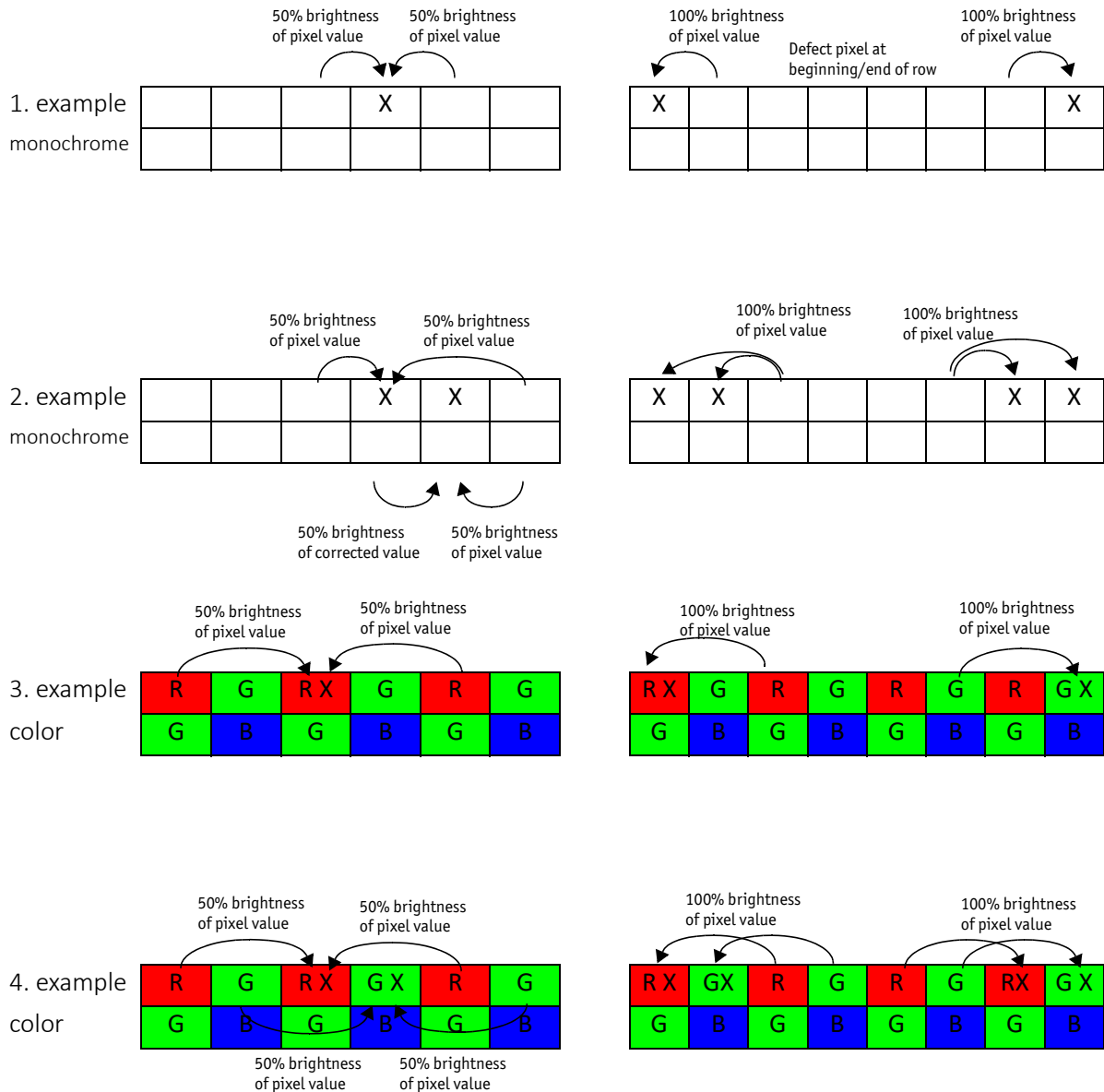

Figure 40: Mechanisms of defect pixel correction

**Note**

While building defect pixel correction data or uploading them from host, the defect pixel correction data are stored **volatile** in FPGA.

Optionally you can store the data in a **non-volatile** memory (Set MemSave to 1).

**Note**

**Configuration**

To configure this feature in an advanced register, see [table 132: on page 238](#).

### Building defect pixel data

**Note**

- Defect pixel correction is only possible in Mono8 modes for monochrome models and Raw8 modes for color models.
- In all other modes you get an error message in advanced register 0xF1000298 bit [1] see [table 132: on page 238](#).
- Using Format\_7 Mode\_x: Defect pixel correction is done in **Format\_7 Mode\_x**.
- Using a fixed format (Format\_0, Format\_1 or Format\_2): Defect pixel correction is done in **Format\_7 Mode\_0**.
- When using defect pixel correction with **binning** and **sub-sampling**: first switch to binning/sub-sampling mode and then apply defect pixel correction.

The following flow diagram illustrates the defect pixel correction.

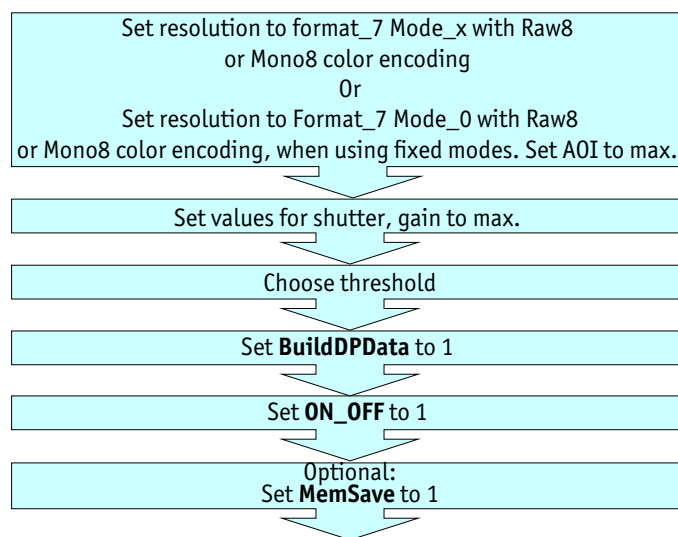

Figure 41: Defect pixel correction: build and store

To build defect pixel data perform the following steps:

#### Grab an image with defect pixel data

1. Take the camera, remove lens and put on lens cap.
2. Set image resolution to Format\_7 Mode\_x or Format\_7 Mode\_0 (when using fixed modes) with Raw8 or Mono8 color encoding, and set AOI to maximum.
3. Set values for shutter and gain to maximum.
4. Grab a single image (one-shot).

#### Calculate defect pixel coordinates

1. Accept default threshold from system or choose own threshold.

#### Note

A mean value is calculated over the entire image that was grabbed previously.



**Definition:** A defect pixel is every pixel value of this previously grabbed image that is:

- greater than (mean value + threshold), or
- less than (mean value - threshold)

2. Set the **BuildDPData** flag to 1.

In microcontroller the defect pixel calculation is started. The detected defect pixel coordinates are stored.

Defect pixel coordinates are:

- 16-bit y-coordinate and
- 16-bit x-coordinate

DPC data are organized like this:

3116 150

y-coordinate	x-coordinate
--------------	--------------

The calculated mean value is written in advanced register **Mean** field (0xF1000298 bit [18..24]).

The number of defect pixels is written in advanced register **DPDataSize** (0xF100029C bit [4..17]). Due to 16-bit format: to get the number of defect pixels read out this value and divide through 4. For more information see [table 132: on page 238](#).

#### Reset values (resolution, shutter, gain, brightness)

1. Take the camera, remove lens cap and thread the lens onto the camera.
2. Reset values for image resolution, shutter, gain and brightness (offset) to their previous values.
3. Grab a single image (one-shot).

### Activate/deactivate defect pixel correction

Activate:

Set ON\_OFF flag to 1.

Deactivate:

Set ON\_OFF flag to 0.

### Store defect pixel data non-volatile

Set the MemSave flag to 1.

### Load non-volatile stored defect pixel data

Set the MemLoad flag to 1.

All non-volatile stored defect pixel coordinates are loaded.

#### Note



- Switch off camera and switch on again:  
⇒ defect pixel data will get lost
- Initialize camera (start-up or soft reset):  
⇒ non-volatile stored defect pixel data are loaded automatically

### Send defect pixel data to the host

1. Set EnaMemRD flag to 1.

Defect pixel data is transferred from dual port RAM to host.

2. Read DPDataSize.

This is the current defect pixel count from the camera.

### Receive defect pixel data from the host

Set EnaMemWR flag to 1.

## Binning (monochrome CCD models and Guppy PRO F-503B, F-503C)

### 2 × binning (Guppy PRO F-503 also 4 ×)

**Definition** Binning is the process of combining neighboring pixels while being read out from the sensor.

#### Note

- Binning does not change offset, brightness or blacklevel.



Binning is used primarily for 3 reasons:

- A reduction in the number of pixels; thus, the amount of data while retaining the original image area angle
- An increase in the frame rate (vertical binning only)

- A brighter image, resulting in an improvement in the signal-to-noise ratio of the image (depending on the acquisition conditions)

**Signal-to-noise ratio (SNR)** and **signal-to-noise separation** specify the quality of a signal with regard to its reproduction of intensities. The value signifies how high the ratio of noise is in regard to the maximum achievable signal intensity.

The higher this value, the better the signal quality. The unit of measurement used is generally known as the decibel (dB), a logarithmic power level. 6 dB is the signal level at approximately a factor of 2.

However, the advantages of increasing signal quality are accompanied by a reduction in resolution.

**Only Format\_7** Binning is possible only in video Format\_7. The type of binning used depends on the video mode.

**Types** In general, we distinguish between the following types of binning (H = horizontal, V = vertical):

- 2 × H-binning
- 2 × V-binning
- 4 × H-binning (Guppy PRO F-503B, F-503C)
- 4 × V-binning (Guppy PRO F-503B, F-503C)

and the full binning modes:

- 2 × full binning (a combination of 2 × H-binning and 2 × V-binning)
- 4 × full binning (a combination of 4 × H-binning and 4 × V-binning) (Guppy PRO F-503B, F-503C)

For Guppy F-503 there are also mixed modes via mode mapping available:

For example:

- 4 × H-binning 2 × V-binning
- 2 × H-binning 4 × V-binning

to and many other mixed modes. For more information see the mapping table of possible Format\_7 modes on page [129](#).

## Vertical binning

**Light sensitivity** Vertical binning increases the light sensitivity of the camera by a factor of two (monochrome CCD models). Guppy PRO F-503B and F-503C have only averaged binning (low-noise binning) without any increase in light sensitivity.

In the **CCD** sensors, this is done directly in the horizontal shift register of the monochrome sensor.

With the **CMOS** sensor of Guppy PRO F-503B and F-503C, monochrome and color binning is possible. The monochrome CMOS sensor of Guppy PRO F-503B uses the same binning patterns as the color version.

**Format\_7 Mode\_2** By default and without further remapping use **Format\_7 Mode\_2** for 2 × vertical binning.

This reduces vertical resolution, depending on the model.

Binning mode	Monochrome CCD models	Guppy PRO F-503B, F-503C
2 × vertical binning	2 pixel signals from 2 vertical neighboring pixels are combined and their signals are added.	2 pixel signals from 2 vertical adjacent same-color pixels are combined and their signals are always averaged (low-noise binning)
4 × vertical binning	not applicable	4 pixel signals from 4 vertical adjacent same-color pixels are combined and their signals are always averaged (low-noise binning)
Averaged? or Added?	Added	Averaged (low-noise binning)
When the signals are averaged, the image will <b>not be brighter</b> than without binning. When the signals are added, the image will be <b>brighter</b> than without binning.		

Table 50: Definition of 2 × and 4 × vertical binning

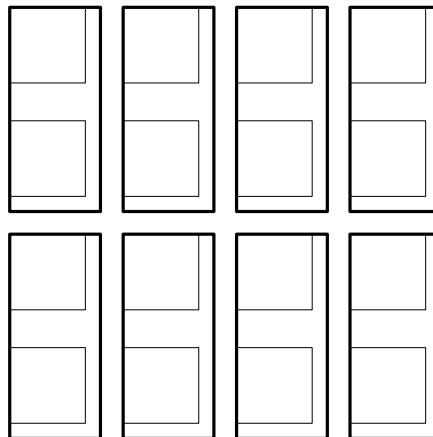

Figure 42: 2 × vertical binning (CCD models)

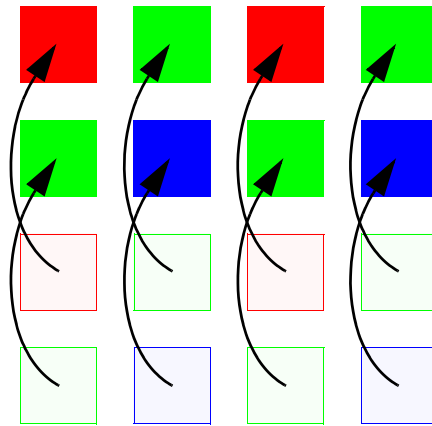

Figure 43: 2 × vertical binning (Guppy PRO F-503B, F-503C)

**Note** Vertical resolution is reduced, but signal-to noise ratio (SNR) is increased by about 3 or 6 dB (2 × or 4 × binning).



**Note** The image appears **vertically** compressed in this mode and no longer exhibits a true aspect ratio.



If **vertical binning** is activated the image may appear to be overexposed and may require correction.

## Horizontal binning

**Definition** (CCD models only) In **horizontal binning** adjacent pixels of a row are combined digitally in the FPGA of the camera without accumulating the black level. CMOS models: horizontal binning is done in the CMOS sensor.

With the CMOS sensor of Guppy PRO F-503C, color binning is possible. The monochrome CMOS sensor of Guppy PRO F-503B uses the same binning patterns as the color version. Using Guppy PRO F-503B, F-503C you can choose between averaging and additive binning.

**Light sensitivity** This means that in horizontal binning the **light sensitivity** of the camera is also increased by a factor of two (6 dB) or 4 (12 dB). This is only true for added binning but not for averaged binning (low-noise binning). Signal-to-noise separation improves by approx. 3 or 6 dB.

**Horizontal resolution** Horizontal resolution is lowered, depending on the model.

**Format\_7 Mode\_1** By default and without further remapping use **Format\_7 Mode\_1** for 2 × horizontal binning.

**Low-noise binning** For Guppy PRO F-503, low-noise binning (averaged pixel signals) is available. To activate this mode see [Low-noise binning mode \(2 × and 4 × binning\) \(Guppy PRO F-503 only\)](#) on page 249.

Binning mode	Monochrome CCD models	Guppy PRO F-503B, F-503C
2 × horizontal binning	2 pixel signals from 2 horizontal neighboring pixels are combined and their signals are added.	2 pixel signals from 2 horizontal adjacent same-color pixels are combined and their signals are added or averaged (low-noise binning). Default: Added
4 × horizontal binning	not applicable	4 pixel signals from 4 horizontal adjacent same-color pixels are combined and their signals are added or averaged (low-noise binning). Default: Added.
Averaged? or Added?	Only added	Added or averaged. Default: added
When the signals are averaged, the image will <b>not be brighter</b> than without binning. When the signals are added, the image will be <b>brighter</b> than without binning.		

Table 51: Definition of 2 × and 4 × horizontal binning

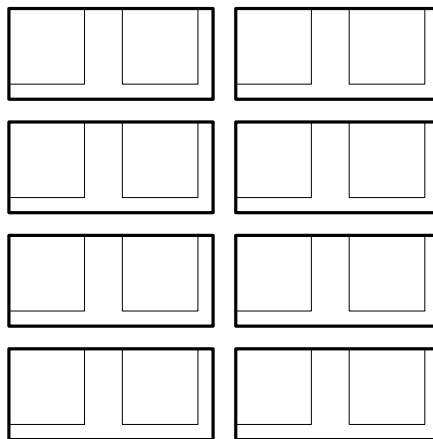

Figure 44: 2 × horizontal binning (CCD models)



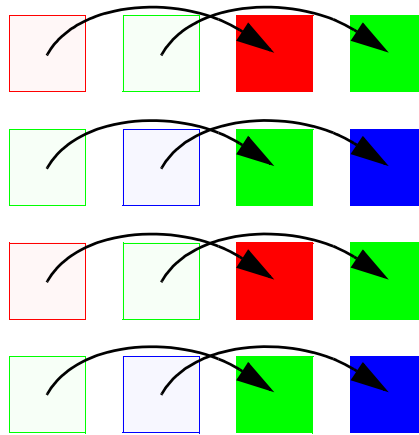

Figure 45: 2 × horizontal binning (Guppy PRO F-503B, F-503C)

**Note**

The image appears **horizontally** compressed in this mode and does no longer show true aspect ratio.



If **horizontal binning** is activated the image may appear to be overexposed and must be corrected, if necessary.

**2 × full binning (Guppy PRO F-503 also 4 × full binning)**

If horizontal and vertical binning are combined, every 4 (16) pixels are consolidated into a single pixel. At first two (4) vertical pixels are put together and then combined horizontally. With the CMOS sensor of Guppy PRO F-503C, color binning is possible. The monochrome CMOS sensor of Guppy PRO F-503B uses the same binning patterns as the color version.

**Light sensitivity** This increases light sensitivity by a total of a factor of 4 (16) and at the same time signal-to-noise separation is improved by about 6 (12) dB (not low-noise binning).

**Resolution** Resolution is reduced, depending on the model.

**Format\_7 Mode\_3** By default and without further remapping use **Format\_7 Mode\_3** for 2 × full binning.

**Low-noise binning** For Guppy PRO F-503, low-noise binning (averaged pixel signals) is available. To activate this mode see [Low-noise binning mode \(2 × and 4 × binning\) \(Guppy PRO F-503 only\)](#) on page 249.

Binning mode	Monochrome CCD models	Guppy PRO F-503B, F-503C
2 × full binning	4 pixel signals from 2 neighboring rows and columns are combined and their signals are added.	4 pixel signals from 2 adjacent rows and columns (same-color pixels) are combined and their signals are horizontally added/averaged and vertically averaged.
4 × full binning	not applicable	16 pixel signals from 4 adjacent rows and columns (same-color pixels) are combined and their signals are horizontally added/averaged and vertically averaged.
Averaged? or Added?	Added	Horizontal: added or averaged Vertical: averaged
When the signal is averaged, the image will not be brighter than without binning. When the signal is added, the image will be brighter than without binning.		

Table 52: Definition of 2 × and 4 × full binning

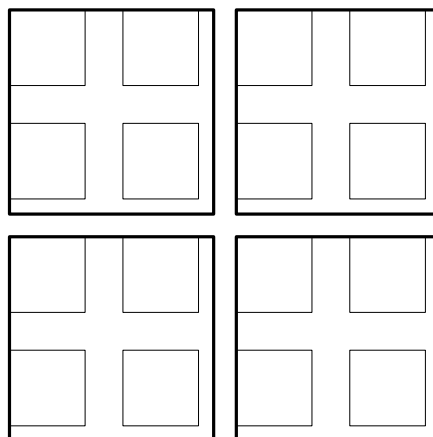

Figure 46: Full binning (CCD models)

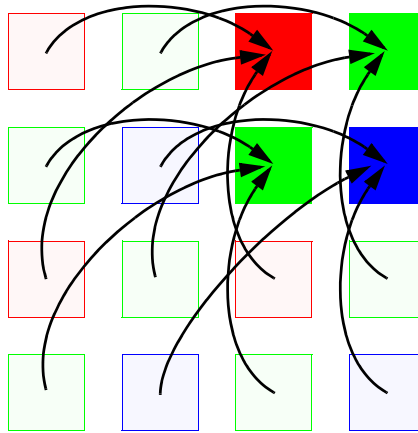

Figure 47: 2 × full binning (Guppy PRO F-503)

**Note**

If **full binning** is activated the image may appear to be overexposed and must be corrected, if necessary.



## Sub-sampling (Guppy PRO F-503B, F-503C and monochrome CCD models)

### What is sub-sampling?

**Definition** Sub-sampling is the process of skipping neighboring pixels (with the same color) while being read out from the CCD chip.

### Which Guppy PRO models have sub-sampling?

- CMOS Guppy PRO models (Guppy PRO F-503B, F-503C) have sub-sampling.
- CCD Guppy PRO models: only monochrome models have sub-sampling (only 2x horizontal/vertical/H+V)

### Description of sub-sampling

Sub-sampling is used primarily for the following reason:

- A reduction in the number of pixels and thus the amount of data while retaining the original image area angle and image brightness

Similar to binning mode the cameras support horizontal, vertical and H+V sub-sampling mode.

**Format\_7 Mode\_4** By default and without further remapping use **Format\_7 Mode\_4** for

- Guppy PRO F-503B: 2 out of 4 horizontal sub-sampling
- Guppy PRO F-503C: 2 out of 4 horizontal sub-sampling

The different sub-sampling patterns are shown below.

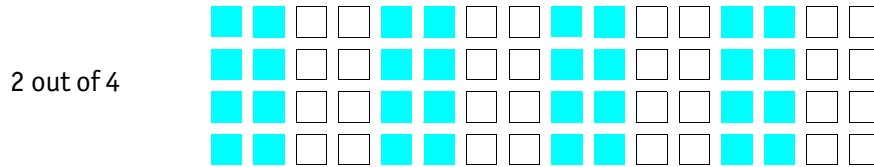

Figure 48: Horizontal sub-sampling 2 out of 4 (monochrome)

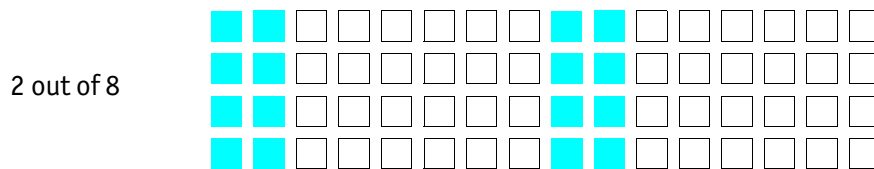

Figure 49: Horizontal sub-sampling 2 out of 8 (monochrome)

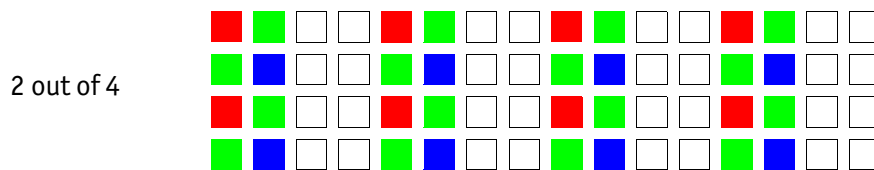

Figure 50: Horizontal sub-sampling 2 out of 4 (color)

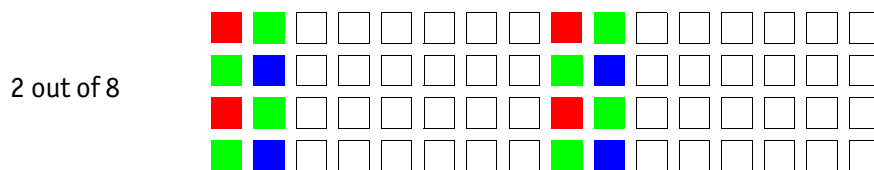

Figure 51: Horizontal sub-sampling 2 out of 8 (color)

**Note**

The image appears **horizontally compressed** in this mode and no longer exhibits a true aspect ratio.



**Format\_7 Mode\_5** By default and without further remapping use **Format\_7 Mode\_5** for

- Guppy PRO F-503B: 2 out of 4 vertical sub-sampling
- Guppy PRO F-503C: 2 out of 4 vertical sub-sampling

The different sub-sampling patterns are shown below.

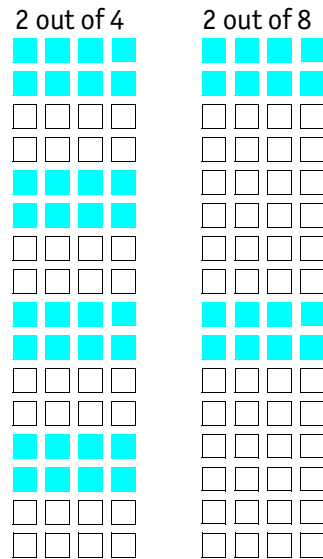

Figure 52: Vertical sub-sampling (monochrome)

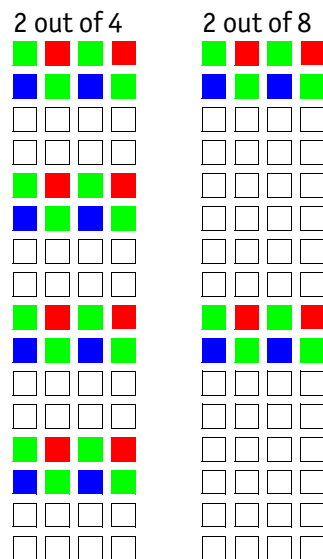

Figure 53: Vertical sub-sampling (color)

**Note**

The image appears vertically compressed in this mode and no longer exhibits a true aspect ratio.



**Format\_7 Mode\_6** By default and without further remapping use **Format\_7 Mode\_6** for 2 out of 4 H + V sub-sampling

The different sub-sampling patterns are shown below.

2 out of 4 H + V sub-sampling

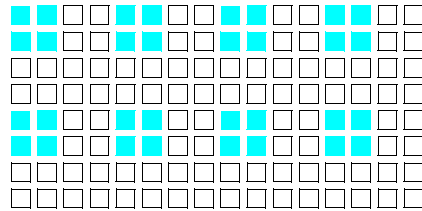

Figure 54: 2 out of 4 H + V sub-sampling (monochrome)

2 out of 8 H+V sub-sampling

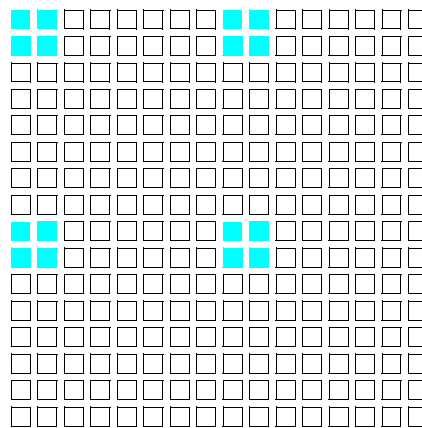

Figure 55: 2 out of 8 H+V sub-sampling (monochrome)

2 out of 4 H+V sub-sampling

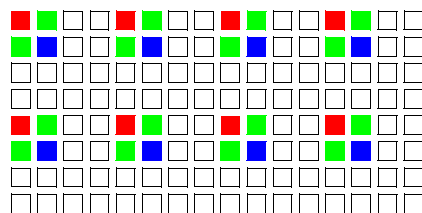

Figure 56: 2 out of 4 H+V sub-sampling (color)

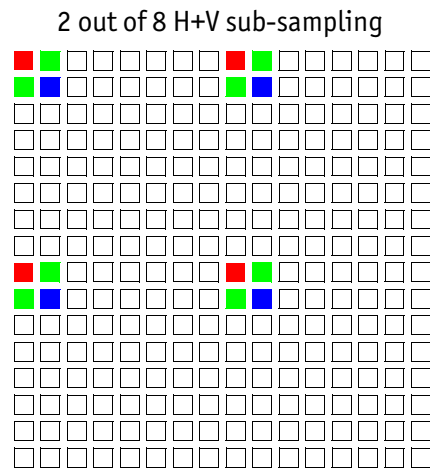

Figure 57: 2 out of 8 H+V sub-sampling (color)

## Binning and sub-sampling access (Guppy PRO F-503B, F-503C, and monochrome CCD models)

The binning and sub-sampling modes described in the last two chapters are only available as pure binning or pure sub-sampling modes. A combination of both is not possible.

As you can see there is a vast amount of possible combinations. But the number of available Format\_7 modes is limited and lower than the possible combinations.

Thus access to the binning and sub-sampling modes is implemented in the following way:

- **Format\_7 Mode\_0** is fixed and cannot be changed
- A maximum of 7 individual Allied Vision modes can be mapped to **Format\_7 Mode\_1 to Mode\_7** (see [figure 58: on page 129](#))
- Mappings can be stored via register (see [Format\\_7 mode mapping \(only Guppy PRO F-503\)](#) on page 248) and are uploaded automatically into the camera on camera reset.
- The **default settings** (per factory) in the Format\_7 modes are listed in the following table

Format_7	Monochrome CCD models	Guppy PRO color
Mode_0	full resolution, no binning, no sub-sampling	full resolution, no sub-sampling, no binning
Mode_1	2 × horizontal binning	2 × horizontal binning
Mode_2	2 × vertical binning	2 × vertical binning

Table 53: Default Format\_7 binning and sub-sampling modes (factory setting)

Format_7	Monochrome CCD models	Guppy PRO color
Mode_3	2 × full binning	2 × full binning
Mode_4	2 out of 4 <b>horizontal</b> sub-sampling	2 out of 4 <b>horizontal</b> sub-sampling
Mode_5	2 out of 4 <b>vertical</b> sub-sampling	2 out of 4 <b>vertical</b> sub-sampling
Mode_6	2 out of 4 <b>full</b> sub-sampling	2 out of 4 <b>full</b> sub-sampling

Table 53: Default Format\_7 binning and sub-sampling modes (factory setting) (continued)

**Note**



- A combination of binning and sub-sampling modes is **not possible**. Use either pure binning or pure sub-sampling modes.
- The Format\_ID numbers 0 to 27 in the binning / sub-sampling list on page 129 do **not** correspond to any of the Format\_7 modes.



F7 modes according to IIDC 1394	Format_ID (see p248) Allied Vision modes			
F7M0 (no change)	0	0 × horizontal	0 × vertical	Binning (F-503 only) monochrome and color models
F7M1	1	2 × horizontal	2 × vertical	
F7M2	2	4 × horizontal		
F7M3	3	---		
F7M4	4	0 × horizontal	4 × vertical	
F7M5	5	2 × horizontal		
F7M6	6	4 × horizontal		
F7M7	7	---		
	8	0 × horizontal	2 out of 2 vertical	Sub-sampling (F-503 only) monochrome and color models
	9	2 × horizontal		
	10	4 × horizontal		
	11	---	2 out of 4 vertical	
	12	---		
	13	---		
	14	---	2 out of 8 vertical	
	15	---		
	16	---		
	17	2 out of 4 horizontal	2 out of 8 vertical	
	18	2 out of 8 horizontal		
	19	---		
	20	2 out of 2 horizontal	2 out of 8 vertical	
	21	2 out of 4 horizontal		
	22	2 out of 8 horizontal		
	23	---		
	24	2 out of 2 horizontal	2 out of 8 vertical	
	25	2 out of 4 horizontal		
	26	2 out of 8 horizontal		
	27	---		

mapping of each of 27 modes to F7M1..F7M7 possible

Figure 58: Mapping of possible Format\_7 modes to F7M1toF7M7 (Guppy PRO F-503 only)  
 For default mappings per factory see page 174

**Note** Configuration

To configure this feature in an advanced register, see [table 143: on page 248](#).

## Packed 12-Bit Mode

All Guppy PRO models have the so-called **Packed 12-Bit Mode**. This means two 12-bit pixel values are packed into 3 bytes instead of 4 bytes.

Monochrome models	Color models
Packed 12-Bit MONO camera mode SmartView: MONO12	Packed 12-Bit RAW camera mode SmartView: RAW12
Mono and raw mode have the same implementation.	

Table 54: Packed 12-Bit Mode

**Note** For data block packet format see [table 38: on page 96](#).



For data structure see [table 42: on page 97](#).

The color codings are implemented via Vendor Unique Color\_Coding according to IIDC V1.31: COLOR\_CODING\_INQ @ 024hto033h, IDs=128-255)

See [table 120: on page 223](#).

Mode	Color_Coding	ID
Packed 12-Bit MONO	ECCID_MONO12	ID=132
Packed 12-Bit RAW	ECCID_RAW12	ID=136

Table 55: Packed 12-Bit Mode: color coding

## Color interpolation (Bayer demosaicing)

The color sensors capture the color information via so-called primary color (R-G-B) filters placed over the individual pixels in a **Bayer mosaic** layout. An effective Bayer → RGB color interpolation already takes place in all Guppy PRO color models.

In color interpolation a red, green or blue value is determined for each pixel. An Allied Vision proprietary Bayer demosaicing algorithm is used for this interpolation (2x2), optimized for both sharpness of contours as well as reduction of false edge coloring.

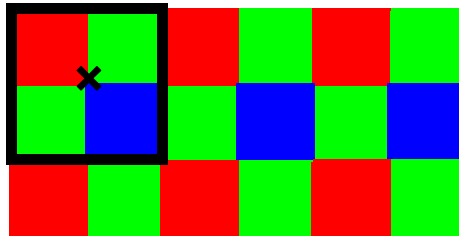

Figure 59: Bayer demosaicing (example of 2x2 matrix)

Color processing can be bypassed by using so-called RAW image transfer.

RAW mode is primarily used to

- save bandwidths on the IEEE1394 bus
- achieve higher frame rates
- use different Bayer demosaicing algorithms on the PC (for all Guppy PRO models the first pixel of the sensor is RED).

**Note**



If the PC does not perform Bayer to RGB post-processing, the monochrome image will be superimposed with a checkerboard pattern.

In color interpolation a red, green or blue value is determined for each pixel. Only two lines are needed for this interpolation:

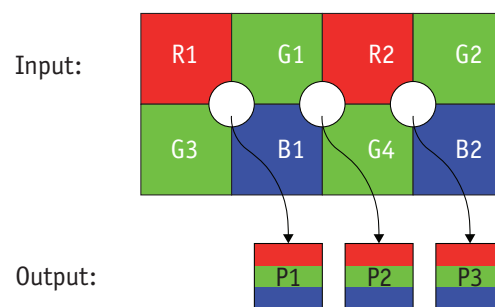

Figure 60: Bayer demosaicing (interpolation)

$$\begin{array}{lll}
 P1_{\text{red}} = R1 & P2_{\text{red}} = R2 & P3_{\text{red}} = R2 \\
 P1_{\text{green}} = \frac{G1 + G3}{2} & P2_{\text{green}} = \frac{G1 + G4}{2} & P3_{\text{green}} = \frac{G2 + G4}{2} \\
 P1_{\text{blue}} = B1 & P2_{\text{blue}} = B1 & P3_{\text{blue}} = B2
 \end{array}$$

*Formula 4: Bayer demosaicing*

## Hue and saturation

Guppy PRO CCD and Guppy PRO F-503 color models are equipped with **hue** and **saturation** registers.

The **hue register** at offset 810h allows the color of objects to be changed without altering the white balance, by +/- 40 steps (+/- 10°) from the nominal perception. Use this setting to manipulate the color appearance after having carried out the white balance.

The **saturation register** at offset 814h allows the intensity of the colors to be changed between 0 and 200% in steps of 1/256.

This means a setting of zero changes the image to black and white and a setting of 511 doubles the color intensity compared to the nominal one at 256.

**Note** Configuration



To configure this feature in feature control register: See offset [810h](#) on page 221 and [814h](#) on page 221.

**Note** Configuration



**Hue and saturation** do not show any effect on Guppy PRO color models in the Raw8 and Raw16 format, because color processing is switched off in all Raw formats.

## Color correction

### Why color correction?

The spectral response of a CCD is different from those of an output device or the human eye. This is the reason for the fact that perfect color reproduction is not possible. In each Guppy PRO camera there is a factory setting for the color correction coefficients, see [GretagMacbeth ColorChecker](#) on page 133.

Color correction is needed to eliminate the overlap in the color channels. This overlap is caused by the fact that:

- Blue light: is seen by the red and green pixels on the CCD
- Red light: is seen by the blue and green pixels on the CCD

- Green light: is seen by the red and blue pixels on the CCD

The color correction matrix subtracts out this overlap.

#### Color correction in Allied Vision cameras

In Allied Vision cameras the color correction is realized as an additional step in the process from the sensor data to color output.

Color correction is used to harmonize colors for the human eye.

Guppy PRO models have the so-called color correction matrix. This means: you are able to manipulate the color-correction coefficients yourself.

#### Color correction: formula

Before converting to the YUV format, color correction on all color models is carried out after Bayer demosaicing via a matrix as follows:

$$\begin{aligned}\text{red}^* &= C_{rr} \times \text{red} + C_{gr} \times \text{green} + C_{br} \times \text{blue} \\ \text{green}^* &= C_{rg} \times \text{red} + C_{gg} \times \text{green} + C_{bg} \times \text{blue} \\ \text{blue}^* &= C_{rb} \times \text{red} + C_{gb} \times \text{green} + C_{bb} \times \text{blue}\end{aligned}$$

*Formula 5: Color correction*

#### GretagMacbeth ColorChecker

Sensor-specific coefficients  $C_{xy}$  are scientifically generated to ensure that GretagMacbeth™ ColorChecker® colors are displayed with highest color fidelity and color balance.

These coefficients are stored in user set 0 and cannot be overwritten (factory setting).

#### Changing color correction coefficients

You can change the color-correction coefficients according to your own needs. Changes are stored in the user settings.

**Note**

- A number of 1000 equals a color correction coefficient of 1.
- To obtain an identity matrix set values of 1000 for the diagonal elements and 0 for all others. As a result you get colors like in the RAW modes.
- The sums of all rows should be equal to each other. If not, you get tinted images.
- Color correction values range -1000 to +2000 and are signed 32 bit.
- In order for white balance to work properly ensure that the row sum equals 1000.
- Each row should sum up to 1000. If not, images are less or more colorful.
- The maximum row sum is limited to 2000.

**Note****Configuration**

To configure the color-correction coefficients in an advanced register, see [table 137: on page 243](#).

To change the color-correction coefficients in **SmartView**, go to **Adv3** tab.

**Switch color correction on/off**

Color correction can also be switched off in YUV mode:

**Note****Configuration**

To configure this feature in an advanced register, see [table 137: on page 243](#).

**Note**

Color correction is deactivated in RAW mode.



## Color conversion (RGB to YUV)

The conversion from RGB to YUV is made using the following formula:

$$Y = 0.3 \times R + 0.59 \times G + 0.11 \times B$$

$$U = -0.169 \times R - 0.33 \times G + 0.498 \times B + 128 \text{ (@ 8 bit)}$$

$$V = 0.498 \times R - 0.420 \times G - 0.082 \times B + 128 \text{ (@ 8 bit)}$$

*Formula 6: RGB to YUV conversion*

### Note



- As mentioned above: Color processing can be bypassed by using so-called RAW image transfer.
- RGB → YUV conversion can be bypassed by using RGB8 format and mode. This is advantageous for edge color definition but needs more bandwidth (300% instead of 200% relative to monochrome or RAW consumption) for the transmission, so that the maximum frame frequency will drop.

## Bulk trigger

See [Trigger modes](#) on page 138 and the following pages.

## Level trigger

See Trigger Mode 1 in [Trigger modes](#) on page 138.

# Controlling image capture

## Global shutter (CCD cameras only)

- Shutter modes** The cameras support the SHUTTER\_MODES specified in IIDC V1.31. For all models (except Guppy PRO F-503) this shutter is a global shutter; meaning that all pixels are exposed to the light at the same moment and for the same time span.
- Pipelined** Pipelined means that the shutter for a new image can already happen, while the preceding image is transmitted.
- Continuous mode** In continuous modes the shutter is opened shortly before the vertical reset happens, thus acting in a frame-synchronous way.
- External trigger** Combined with an external trigger, it becomes asynchronous in the sense that it occurs whenever the external trigger occurs. Individual images are recorded when an external trigger impulse is present. This ensures that even fast moving objects can be grabbed with no image lag and with minimal image blur.
- Software trigger** Guppy PRO cameras know also a trigger initiated by software (status and control register 62Ch on page 218 or in SmartView by Trig/IO tab, Stop trigger button).
- Camera I/O** The external trigger is fed as a TTL signal through Pin 4 of the camera I/O connector.



## Electronic rolling shutter (ERS) and global reset release shutter (GRR) (Guppy PRO F-503 only)

The CMOS Guppy PRO F-503 (ON Semiconductor Aptina CMOS sensor MT9P031) has an electronic rolling shutter (ERS) and a global reset release shutter (GRR) but no global shutter.



Shutter mode Guppy PRO F-503	Description
<p>Electronic rolling shutter (ERS)</p> 	<p>Advantage: designed for maximum frame rates</p> <p>How it works:</p> <ul style="list-style-type: none"> <li>exposure time is the same for all rows</li> <li>start of exposure is different for each row</li> </ul> <p>⇒ This can cause a shear in moving objects, see photo below.</p> <p>Customer action: Use this mode only in situations with non-moving objects.</p> 
<p>Global reset release shutter (GRR)</p>  <p>exposure time different for each row</p>	<p>Advantage: designed for situations with moving objects; use this mode to avoid the problems with ERS described above</p> <p>How it works: Image acquisition is done by starting all rows exposures at the same time.</p> <p>⇒ So there is no shear in moving objects.</p> <ul style="list-style-type: none"> <li>exposure time is different for each row</li> <li>start of exposure is the same for each row</li> </ul> <p>Customer action: Different exposure time for each row will result in images which get brighter with each row (see photo below left). In order to get an image with uniform illumination, use special lighting (flash) or mechanical/LCD extra shutter (see photo below right) which will stop the exposure of all rows simultaneously.</p> 

Table 56: Guppy PRO F-503 shutter modes

## Trigger modes

Guppy PRO cameras support I2C conforming Trigger\_Mode\_0 and Trigger\_Mode\_1 and special Trigger\_Mode\_15 (bulk trigger).

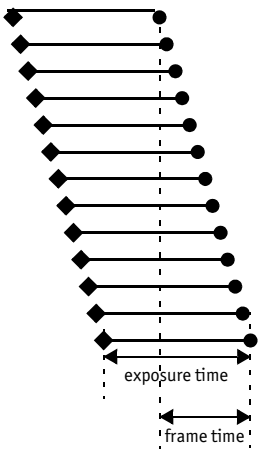
**Note** CMOS cameras Guppy PRO F-503 support only Trigger\_Mode\_0.

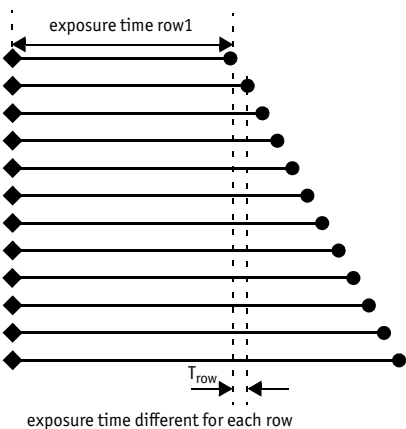
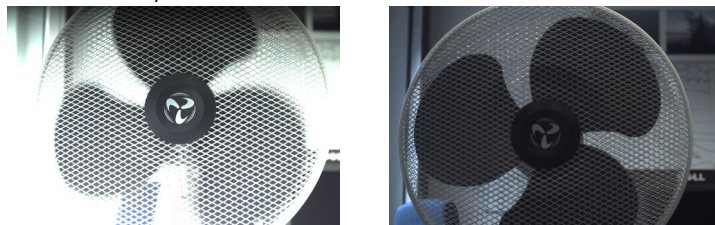

Trigger mode	also known as	Description
Trigger_Mode_0	Edge mode	Sets the shutter time according to the value set in the shutter (or extended shutter) register
Trigger_Mode_1	Level mode	Sets the shutter time according to the active low time of the pulse applied (or active high time in the case of an inverting input)
Trigger_Mode_15	Programmable mode	Is a bulk trigger, combining one external trigger event with continuous or one-shot or multi-shot internal trigger

Table 57: Trigger modes

## Trigger\_Mode\_0 (edge mode) and Trigger\_Mode\_1 (level mode)

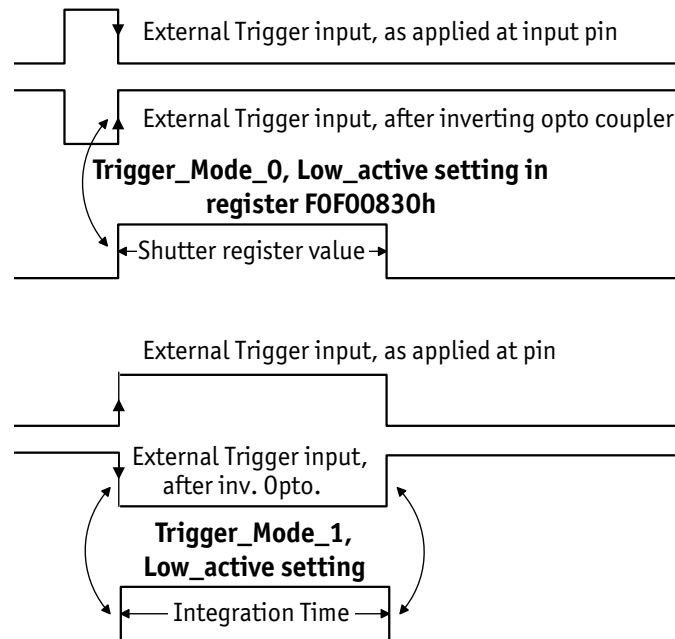

Figure 61: Trigger\_Mode\_0 and 1

The Guppy PRO F-503 has two shutter modes:

- electronic rolling shutter (ERS) and
- global reset release shutter (GRR)

**Note** With this two shutter modes only Trigger\_Mode\_0 is possible. Details are explained in the following diagrams.



### Guppy PRO F-503, Trigger\_Mode\_0, electronic rolling shutter

- IntEna is high, when all pixels are integrated simultaneously.
- IntEna starts with start of exposure of last row.
- IntEna ends with end of exposure of first row.

⇒ No IntEna if exposure of first row ends before the last row starts.

Long exposure time:

To get an IntEna signal the following condition must be true:

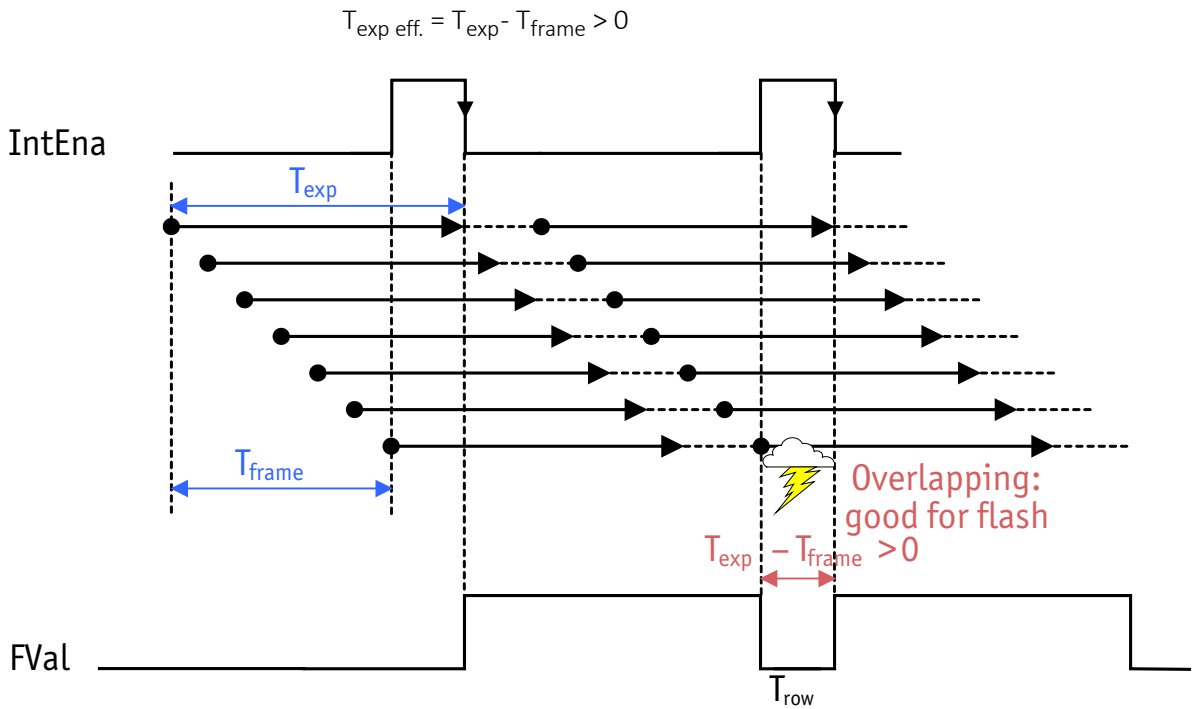

Figure 62: Trigger\_Mode\_0: Guppy PRO F-503 electronic rolling shutter (long exposure time)

Short exposure time:

If the following condition is true:

$$T_{\text{exp eff.}} = T_{\text{exp}} - T_{\text{frame}} < 0$$

you do not get an IntEna signal and triggering is not possible.

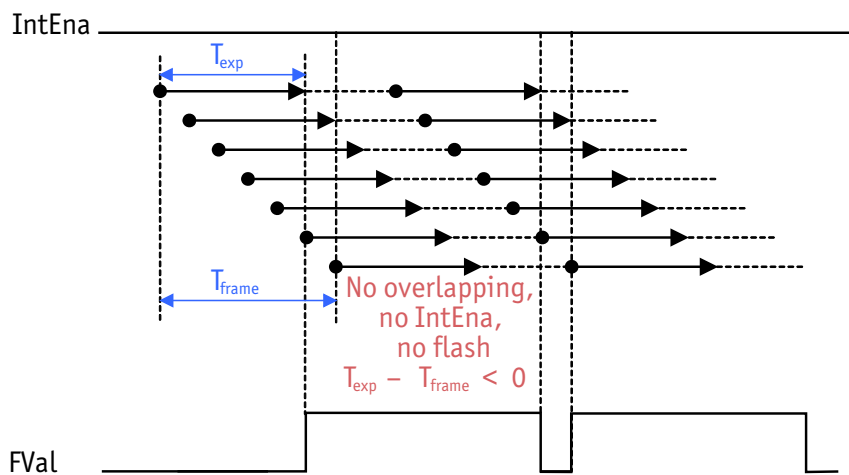

Figure 63: Trigger\_Mode\_0: Guppy PRO F-503 electronic rolling shutter (short exposure time)

**Guppy PRO F-503, Trigger\_Mode\_0, global reset release shutter**

**Note** For activating global reset release shutter in an advanced register, see [table 149](#).



- IntEna is high, when all pixels are integrated simultaneously.
- Readout starts with end of exposure of first row.
- Readout ends with (end of exposure of last row) + (1x  $T_{row}$ ).

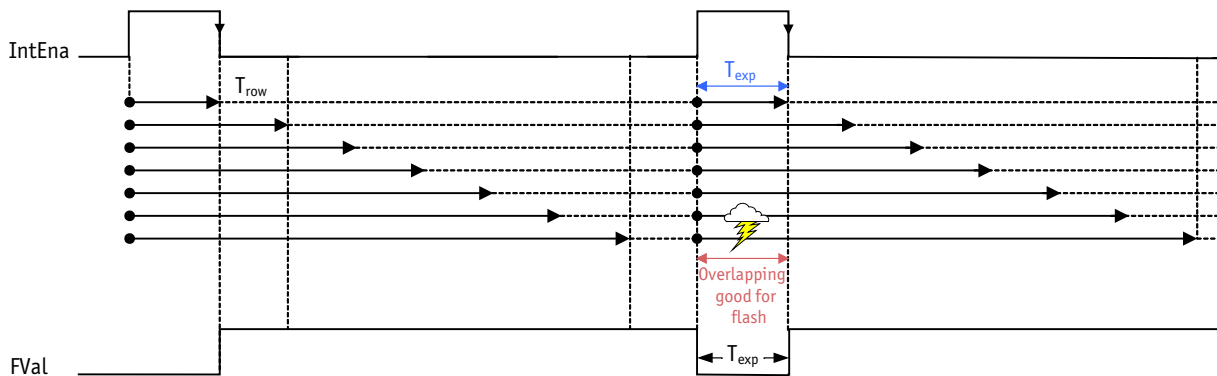

Figure 64: Trigger\_Mode\_0: Guppy PRO F-503: global reset release shutter

Exposure time of first row is:  $T_{exp}$

Exposure time of second row is:  $T_{exp} + T_{row}$

Exposure time of n-th row is:  $T_{exp} + (n-1) \times T_{row}$

Thus the image gets brighter with every row. To prevent this the customer should use:

- flash (when all rows are overlapping, see drawing above)
- or a mechanical/LCD shutter

**Bulk trigger (Trigger\_Mode\_15)**

**Note** Trigger\_Mode\_15 is only available for Guppy PRO CCD cameras.



Trigger\_Mode\_15 is a bulk trigger, combining one external trigger event with continuous or one-shot or multi-shot internal trigger.

It is an extension to the IIDC trigger modes. One external trigger event can be used to trigger a multitude of internal image intakes.

This is especially useful for:

- Grabbing exactly one image based on the first external trigger.
- Filling the camera's internal image buffer with one external trigger without overwriting images.
- Grabbing an unlimited amount of images after one external trigger (surveillance)

The figure below illustrates this mode.

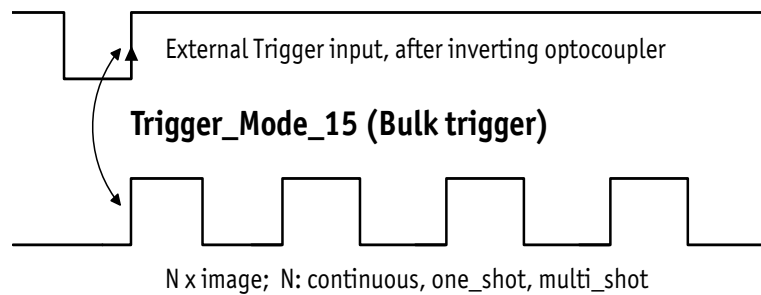

*Figure 65: Trigger\_Mode\_15 (bulk trigger)*

The functionality is controlled via bit [6] and bitgroup [12 to 15] of the following register.

Register	Name	Field	Bit	Description
0xF0F00830	TRIGGER_MODE	Presence_Inq	[0]	Presence of this feature: 0: N/A 1: Available
		Abs_Control	[1]	Absolute value control 0: Control with value in the Value field 1: Control with value in the Absolute value CSR If this bit = 1 the value in the Value field has to be ignored.
		---	[2 to 5]	Reserved
		ON_OFF	[6]	Write: ON or OFF this feature Read: read a status 0: OFF 1: ON If this bit = 0, other fields will be read only.
		Trigger_Polarity	[7]	Select trigger polarity If Polarity_Inq is 1: Write to change polarity of the trigger input. Read to get polarity of the trigger input. If Polarity_Inq is 0: Read only. 0: Low active input 1: High active input
		Trigger_Source	[8 to 10]	Select trigger source Set trigger source ID from trigger source ID_Inq.
		Trigger_Value	[11]	Trigger input raw signal value read only 0: Low 1: High
		Trigger_Mode	[12 to 15]	Trigger_Mode (Trigger_Mode_0 to 15)
		---	[16 to 19]	Reserved
		Parameter	[20 to 31]	Parameter for trigger function, if required (optional)

Table 58: Trigger\_Mode\_15 (Bulk trigger)

The screenshots below illustrate the use of Trigger\_Mode\_15 on a register level:

- Line #1 switches continuous mode off, leaving viewer in listen mode.
- Line #2 prepares 830h register for external trigger and Mode\_15.

Left = continuous	Middle = one-shot	Right = multi-shot
Line #3 switches camera back to continuous mode. Only one image is grabbed precisely with the first external trigger. To repeat rewrite line three.	Line #3 toggles one-shot bit [0] of the one-shot register 61C so that only one image is grabbed, based on the first external trigger. To repeat rewrite line three.	Line #3 toggles multi-shot bit [1] of the one-shot register 61C so that Ah images are grabbed, starting with the first external trigger. To repeat rewrite line three.

Table 59: Description: using Trigger\_Mode\_15: continuous, one-shot, multi-shot

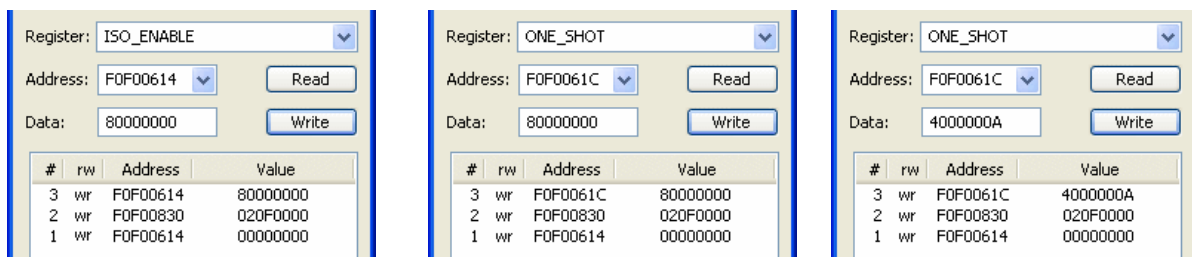

The figure shows three screenshots of a register configuration tool. Each screenshot displays a register name, its address, and the data value being written. Below each register configuration is a table showing the sequence of register writes.

#	rw	Address	Value
3	wr	F0F00614	80000000
2	wr	F0F00830	020F0000
1	wr	F0F00614	00000000

#	rw	Address	Value
3	wr	F0F0061C	80000000
2	wr	F0F00830	020F0000
1	wr	F0F00614	00000000

#	rw	Address	Value
3	wr	F0F0061C	4000000A
2	wr	F0F00830	020F0000
1	wr	F0F00614	00000000

Figure 66: Using Trigger\_Mode\_15: continuous, one-shot, multi-shot

**Note** Shutter for the images is controlled by shutter register.



## Trigger delay

Guppy PRO cameras feature various ways to delay image capture based on external trigger.

With IIDC V1.31 there is a standard CSR at register F0F00534/834h to control a delay up to FFFh × time base value.

The following table explains the Inquiry register and the meaning of the various bits.



Register	Name	Field	Bit	Description
0xF0F00534	TRIGGER_DLY_INQUIRY	Presence_Inq	[0]	Indicates presence of this feature (read only)
		Abs_Control_Inq	[1]	Capability of control with absolute value
		---	[2]	Reserved
		One_Push_Inq	[3]	One-push auto mode (controlled automatically by the camera once)
		ReadOut_Inq	[4]	Capability of reading out the value of this feature
		On_Off_Inq	[5]	Capability of switching this feature ON and OFF
		Auto_Inq	[6]	Auto mode (controlled automatically by the camera)
		Manual_Inq	[7]	Manual mode (controlled by user)
		Min_Value	[8 to 19]	Minimum value for this feature
		Max_Value	[20 to 31]	Maximum value for this feature

Table 60: Trigger delay inquiry register

Register	Name	Field	Bit	Description
0xF0F00834	TRIGGER_DELAY	Presence_Inq	[0]	Presence of this feature: 0: N/A 1: Available
		Abs_Control	[1]	Absolute value control 0: Control with value in the Value field 1: Control with value in the Absolute value CSR If this bit = 1, the value in the Value field has to be ignored
		---	[2 to 5]	Reserved
		ON_OFF	[6]	Write: ON or OFF this feature Read: read a status 0: OFF 1: ON If this bit = 0, other fields will be read only.
		---	[7 to 19]	Reserved
		Value	[20 to 31]	Value  If you write the value in OFF mode, this field will be ignored.  If ReadOut capability is not available, then the read value will have no meaning.

Table 61: CSR: trigger delay

#### Trigger delay advanced register

In addition, the cameras have an advanced register which allows even more precise image capture delay after receiving a hardware trigger.

Register	Name	Field	Bit	Description
0xF1000400	TRIGGER_DELAY	Presence_Inq	[0]	Indicates presence of this feature (read only)
		---	[1 to 5]	Reserved
		ON_OFF	[6]	Trigger delay on/off
		---	[7 to 10]	Reserved
		DelayTime	[11 to 31]	Delay time in $\mu$ s

Table 62: Advanced CSR: trigger delay

The advanced register allows start of the integration to be delayed by max.  $2^{21}$   $\mu$ s, which is max. 2.1 s after a trigger edge was detected.

**Note**

- Switching trigger delay to ON also switches external Trigger\_Mode\_0 to ON.
- This feature works with external Trigger\_Mode\_0 only.

## Software trigger

A software trigger is an external signal that is controlled via a status and control register: 62Ch on page 218: to activate software trigger set bit [0] to 1.

The behavior is different dependent on the trigger mode used:

- Edge mode, programmable mode: trigger is automatically reset (self-cleared).
- Level mode: trigger is active until software trigger register is reset manually.
  - ⇒ in advanced register 62Ch on page 218: set bit [0] to 0
  - ⇒ in SmartView: Trig/IO tab, stop trigger button

## Debounce

Only for input ports:

There is an adjustable debounce time for trigger: separate for each input pin. The debounce time is a waiting period where no new trigger is allowed. This helps you to set exactly one trigger.

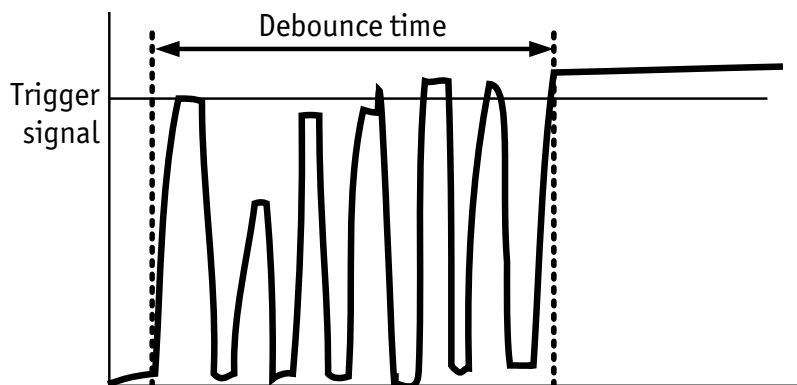

Figure 67: Example of debounce time for trigger

To set this feature in an advanced register: see [Debounce time](#) on page 148.

To set this feature in SmartView: Trig/IO tab, Input pins table, Debounce column.

## Debounce time

This register controls the debounce feature of the cameras input pins. The debounce time can be set for each available input separately.

Increment is 500 ns

Debounce time is set in  $\text{Time} \times 500 \text{ ns}$

Minimum debounce time is  $1.5 \mu\text{s} \Rightarrow 3 \times 500 \text{ ns}$

Maximum debounce time is  $\sim 16 \text{ ms} \Rightarrow (2^{15}-1) \times 500 \text{ ns}$

Offset	Name	Field	Bit	Description
0xF1000840	IO_INP_DEBOUNCE_1	Presence_Inq	[0]	Indicates presence of this feature (read only)
		---	[2 to 7]	Reserved
		Time	[8 to 31]	Debounce time in steps of 500 ns (24 bit) see examples above
0xF1000844		MinValue	[0 to 31]	Minimum debounce time
0xF1000848		MaxValue	[0 to 31]	Maximum debounce time
0xF100084C		---	[0 to 31]	Reserved
0xF1000850	IO_INP_DEBOUNCE_2			same as IO_INP_DEBOUNCE_1
0xF1000860	IO_INP_DEBOUNCE_3			same as IO_INP_DEBOUNCE_1
0xF1000870	IO_INP_DEBOUNCE_4			same as IO_INP_DEBOUNCE_1
0xF1000880				Reserved
0xF1000890				Reserved
0xF10008A0				Reserved
0xF10008B0				Reserved

Table 63: Advanced register: Debounce time for input ports

### Note



- The camera corrects invalid values automatically.
- This feature is not stored in the user settings.

## Exposure time (shutter) and offset

The exposure (shutter) time for continuous mode and Trigger\_Mode\_0 is based on the following formula:

Shutter register value × time base + offset

The register value is the value set in the corresponding IIDC 1.31 register (SHUTTER [81Ch]). This number is in the range between 1 and 4095.

The shutter register value is multiplied by the time base register value (see [table 128](#):). The default value here is set to 20 μs.

### Exposure time of Guppy PRO F-503

The exposure time of Guppy PRO F-503 can be set in row time increments.

The formula for the row time is:

$$t_{\text{row}} = (10.42 \text{ ns} \times \text{width}) + 9.375 \text{ } \mu\text{s}$$

*Formula 7: Row time for Guppy PRO F-503 (CMOS)*

The minimum row time and the row time by maximum resolution are:

$$\begin{aligned} t_{\text{row min}} &= 10.042 \text{ } \mu\text{s} \\ t_{\text{row max res}} &= 36.375 \text{ } \mu\text{s} \end{aligned}$$

*Formula 8: Min. row time and row time at max. resolution for Guppy PRO F-503 (CMOS)*

The shutter time of Guppy PRO F-503 can be extended via the advanced register: EXTENDED\_SHUTTER

For more information see [Extended shutter](#) on page 233 and [table 129](#):

### Exposure time offset

A camera-specific offset is also added to this value. It is different for the camera models:

Model	Exposure time offset
Guppy PRO F-031	71 $\mu$ s
Guppy PRO F-032	27 $\mu$ s
Guppy PRO F-033	27 $\mu$ s
Guppy PRO F-046	27 $\mu$ s
Guppy PRO F-125	35 $\mu$ s
Guppy PRO F-146	31 $\mu$ s
Guppy PRO F-201	45 $\mu$ s
Guppy PRO F-503	see <a href="#">Exposure time of Guppy PRO F-503</a> on page 149

Table 64: Model-specific exposure time offset

## Minimum exposure time

Model	Minimum exposure time	Effective min. exp. time = Min. exp. time + offset
Guppy PRO F-031	4 $\mu$ s	4 $\mu$ s + 71 $\mu$ s = 75 $\mu$ s
Guppy PRO F-032	10 $\mu$ s	10 $\mu$ s + 27 $\mu$ s = 37 $\mu$ s
Guppy PRO F-033	4 $\mu$ s	4 $\mu$ s + 27 $\mu$ s = 31 $\mu$ s
Guppy PRO F-046	4 $\mu$ s	4 $\mu$ s + 27 $\mu$ s = 31 $\mu$ s
Guppy PRO F-125	4 $\mu$ s	4 $\mu$ s + 35 $\mu$ s = 39 $\mu$ s
Guppy PRO F-146	10 $\mu$ s	10 $\mu$ s + 31 $\mu$ s = 41 $\mu$ s
Guppy PRO F-201	10 $\mu$ s	10 $\mu$ s + 45 $\mu$ s = 55 $\mu$ s
Guppy PRO F-503	see <a href="#">Exposure time of Guppy PRO F-503</a> on page 149	

Table 65: Model-specific minimum exposure time

### Example: Guppy PRO F-031

Camera	Register value	Time base (default)
Guppy PRO F-031	100	20 $\mu$ s

Table 66: Register value and time base for Guppy PRO F-031

register value  $\times$  time base + exposure time offset = exposure time

$100 \times 20 \mu\text{s} + 71 \mu\text{s} = 2075 \mu\text{s}$  exposure time

The minimum adjustable exposure time set by register is 4  $\mu$ s.  $\rightarrow$  The real minimum exposure time of Guppy PRO F-031 is then:

$4 \mu\text{s} + 71 \mu\text{s} = 75 \mu\text{s}$

## Extended shutter

The exposure time for long-term integration of

- up to 67 seconds for the CCD models
- up to 22 seconds for the Guppy PRO F-503 (CMOS model)

can be extended via the advanced register: EXTENDED\_SHUTTER

Register	Name	Field	Bit	Description
0xF100020C	EXTD_SHUTTER	Presence_Inq	[0]	Indicates presence of this feature (read only)
		---	[1 to 5]	Reserved
		ExpTime	[6 to 31]	Exposure time in $\mu$ s

Table 67: Advanced register: Extended shutter

The longest exposure time, 3FFFFFFh, corresponds to 67.11 sec.

The lowest possible value of ExpTime is camera-specific (see [table 64](#)).

### Note



- Exposure times entered via the 81Ch register are mirrored in the extended register, but not vice versa.
- Longer integration times not only increase sensitivity, but may also increase some unwanted effects such as noise and pixel-to-pixel non-uniformity. Depending on the application, these effects may limit the longest usable integration time.
- Changes in this register have immediate effect, even when the camera is transmitting.
- Extended shutter becomes inactive after writing to a format/mode/frame rate register.

## One-shot

Guppy PRO cameras can record an image by setting the one-shot bit in the 61Ch register. This bit is automatically cleared after the image is captured. If the camera is placed in ISO\_Enable mode (see [ISO\\_Enable / free-run](#) on page 155), this flag is ignored.

If one-shot mode is combined with the external trigger, the one-shot command is used to arm it. The following screenshot shows the sequence of commands needed to put the camera into this mode. It enables the camera to grab exactly one image with an external trigger edge.

If there is no trigger impulse after the camera has been armed, one-shot can be canceled by clearing the bit.

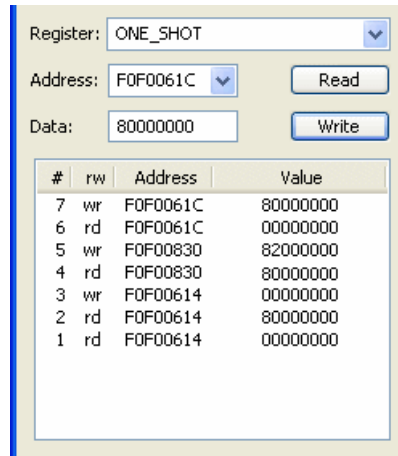

Figure 68: One-shot control (SmartView)

#	Read = rd Write = wr	Address	Value	Description
7	wr	F0F0061C	80000000	Do one-shot.
6	rd	F0F0061C	00000000	Read out one-shot register.
5	wr	F0F00830	82000000	Switch on external trigger mode 0.
4	rd	F0F00830	80000000	Check trigger status.
3	wr	F0F00614	00000000	Stop free-run.
2	rd	F0F00614	80000000	Check Iso_Enable mode (⇒ free-run).
1	rd	F0F00614	00000000	This line is produced by SmartView.

Table 68: One-shot control: Descriptions

### One-shot command on the bus to start of exposure

The following sections describe the time response of the camera using a single frame (one-shot) command. As set out in the IIDC specification, this is a software command that causes the camera to record and transmit a single frame.

The following values apply only when the camera is idle and ready for use. Full resolution must also be set.



Feature	Value
One-shot → microcontroller sync	≤ 150 μs (processing time in the microcontroller)
μC-Sync/ExSync → integration start	8 μs

*Table 69: Values for one-shot*

Microcontroller sync is an internal signal. It is generated by the microcontroller to initiate a trigger. This can either be a direct trigger or a release for ExSync if the camera is externally triggered.

### End of exposure to first packet on the bus

After the exposure, the CCD sensor is read out; some data is written into the FRAME\_BUFFER before being transmitted to the bus.

The time from the end of exposure to the start of transport on the bus is:

710 μs ± 62.5 μs

This time *jitters* with the cycle time of the bus (125  $\mu$ s).

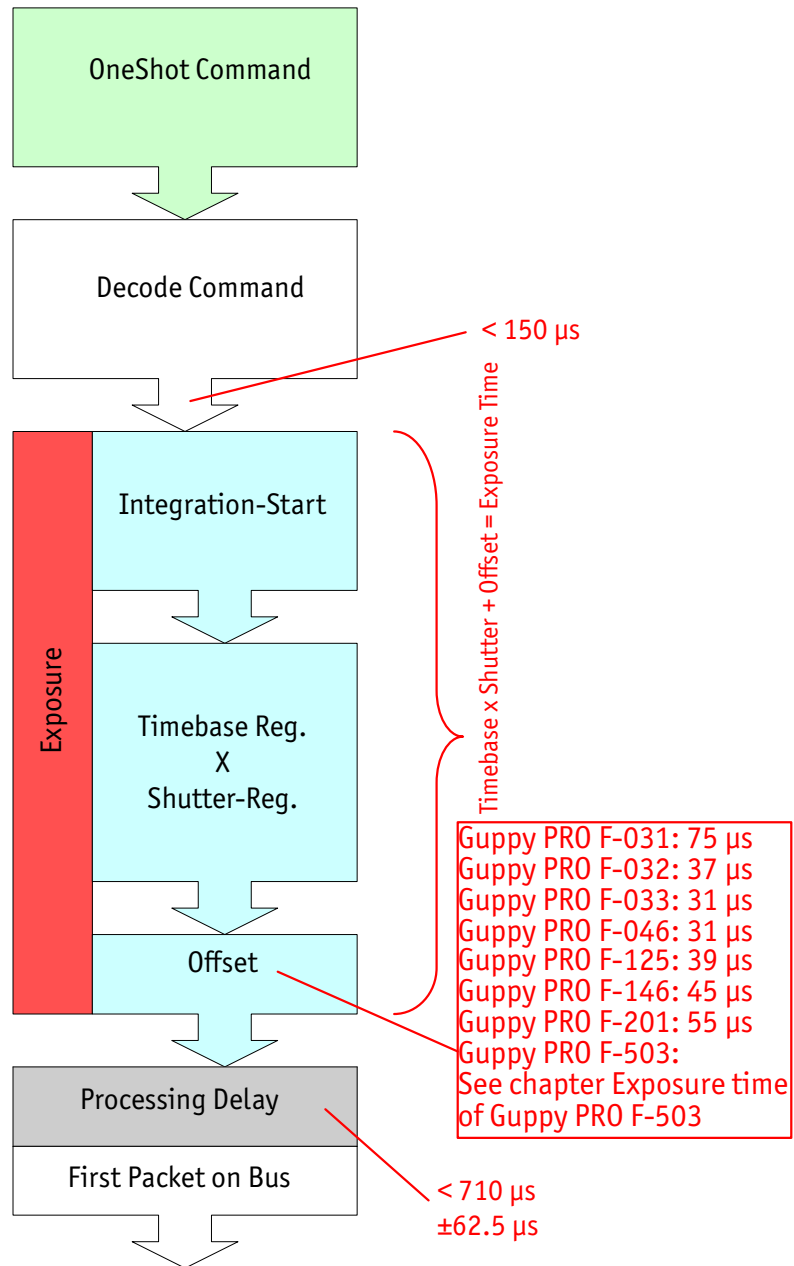

Figure 69: Data flow and timing after end of exposure

## Multi-shot

Setting multi-shot and entering a quantity of images in Count\_Number in the 61Ch register enables the camera to record a specified number of images.

The number is indicated in bits 16 to 31. If the camera is put into ISO\_Enable mode (see [ISO\\_Enable / free-run](#) on page 155), this flag is ignored and deleted automatically once all the images have been recorded.

If multi-shot mode is activated and the images have not yet all been captured, it can be cancelled by resetting the flag. The same result can be achieved by setting the number of images to 0.

Multi-shot can also be combined with the external trigger in order to grab a certain number of images based on an external trigger.

## ISO\_Enable / free-run

Setting the MSB (bit 0) in the 614h register (ISO\_ENA) puts the camera into ISO\_Enable mode or Continuous\_Shot (free-run). The camera captures an infinite series of images. This operation can be quit by deleting the 0 bit.

## Asynchronous broadcast

The camera accepts asynchronous broadcasts. This involves asynchronous write requests that use node number 63 as the target node with no acknowledge.

This makes it possible for all cameras on a bus to be triggered by software simultaneously - e.g. by broadcasting a one-shot. All cameras receive the one-shot command in the same IEEE1394 bus cycle. This creates uncertainty for all cameras in the range of 125  $\mu$ s.

Inter-camera latency is described in [Jitter at start of exposure](#) on page 156.

The following screenshot shows an example of broadcast commands sent with the Firedemo example of FirePackage:



Figure 70: Broadcast one-shot

- Line 1 shows the broadcast command, which stops all cameras connected to the same IEEE1394 bus. It is generated by holding the Shift key down while clicking on Write.
- Line 2 generates a broadcast one\_shot in the same way, which forces all connected cameras to simultaneously grab one image.

## Jitter at start of exposure

The following chapter discusses the latency time which exists for all Guppy PRO CCD models when a hardware trigger is generated, until the actual image exposure starts.

Owing to the well-known fact that an Interline Transfer CCD sensor has both a light sensitive area and a separate storage area, it is common to interleave image exposure of a new frame and output that of the previous one. It makes continuous image flow possible, even with an external trigger. The uncertain time delay before the start of exposure depends on the state of the sensor. A distinction is made as follows:

FVal is active → the sensor is reading out, the camera is busy

In this case the camera must not change horizontal timing so that the trigger event is synchronized with the current horizontal clock. This introduces a maximum uncertainty which is equivalent to the row time. The row time depends on the sensor used and, therefore, can vary from model to model.

FVal is inactive → the sensor is ready, the camera is idle

In this case the camera can resynchronize the horizontal clock to the new trigger event, leaving only a very short uncertainty time of the master clock period.

Model	Exposure start jitter (while FVal)	Exposure start jitter (while camera idle)
Guppy PRO F-031	± 14.2 μs	± 2.9 μs
Guppy PRO F-032	± 24.3 μs	± 3.0 μs
Guppy PRO F-033	± 23.4 μs	± 2.6 μs
Guppy PRO F-046	± 27.4 μs	± 2.6 μs
Guppy PRO F-125	± 33.2 μs	± 5.0 μs
Guppy PRO F-146	± 56.0 μs	± 13.7 μs
Guppy PRO F-201	± 29.5 μs	± 10.3 μs
Guppy PRO F-503	not applicable	not applicable

Table 70: Jitter at exposure start (no binning, no sub-sampling)

**Note**

Jitter at the beginning of an exposure has no effect on the length of exposure, i.e. it is always constant.



## Video formats, modes and bandwidth

The different Guppy PRO models support different video formats, modes and frame rates.

These formats and modes are standardized in the IIDC (formerly DCAM) specification.

Resolutions smaller than the generic sensor resolution are generated from the center of the sensor and without binning.

### Note



- The maximum frame rates can only be achieved with shutter settings lower than  $1/(\text{frame rate})$ . This means that with default shutter time of 40 ms, a camera will not achieve frame rates higher than 25 frames/s. In order to achieve higher frame rates, please reduce the shutter time proportionally.
- The following tables assume that bus speed is 800 Mbit/s. With lower bus speeds (e.g. 400, 200 or 100 Mbit/s) not all frame rates may be achieved.
- For information on bit/pixel and byte/pixel for each color mode see [Table 99](#).

### Note



The following Format\_7 tables show default Format\_7 modes without Format\_7 mode mapping.

For information on Format\_7 mode mapping to

- to see [figure 58](#):
- to see [Format\\_7 mode mapping \(only Guppy PRO F-503\)](#) on page 248

### Note



H-binning means horizontal binning.

V-binning means vertical binning.

Full binning (H+V) means horizontal + vertical binning

2 × binning means: 2 neighboring pixels are combined.

4 × binning means: 4 neighboring pixels are combined.

- Binning increases signal-to-noise ratio (SNR), but decreases resolution.

## Guppy PRO F-031B, F-031C

Format	Mode	Resolution	Color mode	120 fps	60 fps	30 fps	15 fps	7.5 fps	3.75 fps	1.875 fps
0	0	160 × 120	YUV444							
	1	320 × 240	YUV422		×	×	×	×	×	×
	2	640 × 480	YUV411		×	×	×	×	×	×
	3	640 × 480	YUV422		×	×	×	×	×	×
	4	640 × 480	RGB8		×	×	×	×	×	×
	5	640 × 480	Mono8	× ×*	× ×*	× ×*	× ×*	× ×*	× ×*	× ×*
	6	640 × 480	Mono16		×	×	×	×	×	×

Table 71: Video fixed formats Guppy PRO F-031B, F-031C

\*: Color camera outputs Mono8 interpolated image.

 Only achievable with IEEE1394b (S800).

### Note



The following table shows default Format\_7 modes without Format\_7 mode mapping.

For information on Format\_7 mode mapping to

- see [figure 58](#):
- see [Format\\_7 mode mapping \(only Guppy PRO F-503\)](#) on page 248

Format	Mode	Resolution	Color mode	Maximum S800 frame rates for Format_7 modes
7	0	656 × 492	Mono8	123 fps
			Mono12	123 fps
			Mono16	120 fps
		656 × 492	YUV411	123 fps
			YUV422,Raw16	101 fps
			Mono8,Raw8	123 fps
			RGB8	67 fps
	Raw12	123 fps		
1	328 × 492	Mono8	123 fps2x H-binning	
		Mono12	123 fps2x H-binning	
		Mono16	123 fps2x H-binning	
	2	656 × 246	Mono8	205 fps2x V-binning
			Mono12	205 fps2x V-binning
			Mono16	199 fps2x V-binning
	3	328 × 246	Mono8	205 fps2x H+V binning
Mono12			205 fps2x H+V binning	
Mono16			205 fps2x H+V binning	
4	328 × 492	Mono8	123 fps2 out of 4 H-sub-sampling	
		Mono12	123 fps2 out of 4 H-sub-sampling	
		Mono16	123 fps2 out of 4 H-sub-sampling	
5	656 × 246	Mono8	154 fps2 out of 4 V-sub-sampling	
		Mono12	154 fps2 out of 4 V-sub-sampling	
		Mono16	154 fps2 out of 4 V-sub-sampling	
6	328 × 246	Mono8	154 fps2 out of 4 H+V sub-sampling	
		Mono12	154 fps2 out of 4 H+V sub-sampling	
		Mono16	154 fps2 out of 4 H+V sub-sampling	

Table 72: Video Format\_7 default modes Guppy PRO F-031B, F-031C



## Guppy PRO F-032B, F-032C

Format	Mode	Resolution	Color mode	60 fps	30 fps	15 fps	7.5 fps	3.75 fps	1.875 fps
0	0	160 × 120	YUV444						
	1	320 × 240	YUV422	×	×	×	×	×	×
	2	640 × 480	YUV411	×	×	×	×	×	×
	3	640 × 480	YUV422	×	×	×	×	×	×
	4	640 × 480	RGB8	×	×	×	×	×	×
	5	640 × 480	Mono8	× ×*	× ×*	× ×*	× ×*	× ×*	× ×*
	6	640 × 480	Mono16	×	×	×	×	×	×

Table 73: Video fixed formats Guppy PRO F-032B, F-032C

\*: Color camera outputs Mono8 interpolated image.

 Only achievable with IEEE1394b (S800).

### Note



The following table shows default Format\_7 modes without Format\_7 mode mapping.

For information on Format\_7 mode mapping to

- see [figure 58](#):
- see [Format\\_7 mode mapping \(only Guppy PRO F-503\)](#) on page 248

Format	Mode	Resolution	Color mode	Maximum S800 frame rates for Format_7 modes
7	0	656 × 492	Mono8	82 fps
			Mono12	82 fps
			Mono16	82 fps
		656 × 492	YUV411	82 fps
			YUV422,Raw16	82 fps
			Mono8,Raw8	82 fps
			RGB8	66 fps
	Raw12	82 fps		
1	328 × 492	Mono8	79 fps2x H-binning	
		Mono12	79 fps2x H-binning	
		Mono16	79 fps2x H-binning	
2	656 × 246	Mono8	136 fps2x V-binning	
		Mono12	136 fps2x V-binning	
		Mono16	136 fps2x V-binning	
3	328 × 246	Mono8	136 fps2x H+V binning	
		Mono12	136 fps2x H+V binning	
		Mono16	136 fps2x H+V binning	
4	328 × 492	Mono8	79 fps2 out of 4 H-sub-sampling	
		Mono12	79 fps2 out of 4 H-sub-sampling	
		Mono16	79 fps2 out of 4 H-sub-sampling	
5	656 × 246	Mono8	100 fps2 out of 4 V-sub-sampling	
		Mono12	100 fps2 out of 4 V-sub-sampling	
		Mono16	100 fps2 out of 4 V-sub-sampling	
6	328 × 246	Mono8	100 fps2 out of 4 H+V sub-sampling	
		Mono12	100 fps2 out of 4 H+V sub-sampling	
		Mono16	100 fps2 out of 4 H+V sub-sampling	

Table 74: Video Format\_7 default modes Guppy PRO F-032B, F-032C

## Guppy PRO F-033B, F-033C

Format	Mode	Resolution	Color mode	60 fps	30 fps	15 fps	7.5 fps	3.75 fps	1.875 fps
0	0	160 × 120	YUV444						
	1	320 × 240	YUV422	×	×	×	×	×	×
	2	640 × 480	YUV411	×	×	×	×	×	×
	3	640 × 480	YUV422	×	×	×	×	×	×
	4	640 × 480	RGB8	×	×	×	×	×	×
	5	640 × 480	Mono8	× ×*	× ×*	× ×*	× ×*	× ×*	× ×*
	6	640 × 480	Mono16	×	×	×	×	×	×

Table 75: Video fixed formats Guppy PRO F-033B, F-033C

\*: Color camera outputs Mono8 interpolated image.

 Only achievable with IEEE1394b (S800).

### Note



The following table shows default Format\_7 modes without Format\_7 mode mapping.

For information on Format\_7 mode mapping to

- see [figure 58](#):
- see [Format\\_7 mode mapping \(only Guppy PRO F-503\)](#) on page 248

Format	Mode	Resolution	Color mode	Maximum S800 frame rates for Format_7 modes
7	0	656 × 492	Mono8	85 fps
			Mono12	85 fps
			Mono16	85 fps
		656 × 492	YUV411	85 fps
			YUV422,Raw16	85 fps
			Mono8,Raw8	85 fps
			RGB8	67 fps
	Raw12	85 fps		
1	328 × 492	Mono8	84 fps2x H-binning	
		Mono12	84 fps2x H-binning	
		Mono16	84 fps2x H-binning	
2	656 × 246	Mono8	149 fps2x V-binning	
		Mono12	149 fps2x V-binning	
		Mono16	149 fps2x V-binning	
3	328 × 246	Mono8	149 fps2x H+V binning	
		Mono12	149 fps2x H+V binning	
		Mono16	149 fps2x H+V binning	
4	328 × 492	Mono8	84 fps2 out of 4 H-sub-sampling	
		Mono12	84 fps2 out of 4 H-sub-sampling	
		Mono16	84 fps2 out of 4 H-sub-sampling	
5	656 × 246	Mono8	108 fps2 out of 4 V-sub-sampling	
		Mono12	108 fps2 out of 4 V-sub-sampling	
		Mono16	108 fps2 out of 4 V-sub-sampling	
6	328 × 246	Mono8	108 fps2 out of 4 H+V sub-sampling	
		Mono12	108 fps2 out of 4 H+V sub-sampling	
		Mono16	108 fps2 out of 4 H+V sub-sampling	

Table 76: Video Format\_7 default modes Guppy PRO F-033B, F-033C

## Guppy PRO F-046B, F-046C

Format	Mode	Resolution	Color mode	60 fps	30 fps	15 fps	7.5 fps	3.75 fps	1.875 fps
0	0	160 × 120	YUV444						
	1	320 × 240	YUV422	×	×	×	×	×	×
	2	640 × 480	YUV411	×	×	×	×	×	×
	3	640 × 480	YUV422	×	×	×	×	×	×
	4	640 × 480	RGB8	×	×	×	×	×	×
	5	640 × 480	Mono8	× ×*	× ×*	× ×*	× ×*	× ×*	× ×*
	6	640 × 480	Mono16	×	×	×	×	×	×

Table 77: Video fixed formats Guppy PRO F-046B, F-046C

\*: Color camera outputs Mono8 interpolated image.

 Only achievable with IEEE1394b (S800).

### Note



The following table shows default Format\_7 modes without Format\_7 mode mapping.

For information on Format\_7 mode mapping to

- see [figure 58](#):
- see [Format\\_7 mode mapping \(only Guppy PRO F-503\)](#) on page 248

Format	Mode	Resolution	Color mode	Maximum S800 frame rates for Format_7 modes
7	0	780 × 580	Mono8	62 fps
			Mono12	41 fps
			Mono16	30 fps
		780 × 580	YUV411	62 fps
			YUV422,Raw16	62 fps
			Mono8,Raw8	62 fps
		RGB8	48 fps	
		Raw12	62 fps	
1	388 × 580	Mono8	61 fps2x H-binning	
		Mono12	61 fps2x H-binning	
		Mono16	61 fps2x H-binning	
	2	780 × 290	Mono8	111 fps2x V-binning
			Mono12	111 fps2x V-binning
			Mono16	111 fps2x V-binning
	3	388 × 290	Mono8	111 fps2x H+V binning
Mono12			111 fps2x H+V binning	
Mono16			111 fps2x H+V binning	
4	388 × 580	Mono8	61 fps2 out of 4 H-sub-sampling	
		Mono12	61 fps2 out of 4 H-sub-sampling	
		Mono16	61 fps2 out of 4 H-sub-sampling	
5	780 × 290	Mono8	78 fps2 out of 4 V-sub-sampling	
		Mono12	78 fps2 out of 4 V-sub-sampling	
		Mono16	79 fps2 out of 4 V-sub-sampling	
6	388 × 290	Mono8	79 fps2 out of 4 H+V sub-sampling	
		Mono12	79 fps2 out of 4 H+V sub-sampling	
		Mono16	79 fps2 out of 4 H+V sub-sampling	

Table 78: Video Format\_7 default modes Guppy PRO F-046B, F-046C

## Guppy PRO F-125B, F-125C

Format	Mode	Resolution	Color mode	60 fps	30 fps	15 fps	7.5 fps	3.75 fps	1.875 fps
0	0	160 × 120	YUV444						
	1	320 × 240	YUV422	×	×	×	×	×	×
	2	640 × 480	YUV411		×	×	×	×	×
	3	640 × 480	YUV422		×	×	×	×	×
	4	640 × 480	RGB8		×	×	×	×	×
	5	640 × 480	Mono8		× ×*	× ×*	× ×*	× ×*	× ×*
	6	640 × 480	Mono16		×	×	×	×	×
1	0	800 × 600	YUV422		×	×	×	×	
	1	800 × 600	RGB8		×	×	×		
	2	800 × 600	Mono8		× ×*	× ×*	× ×*		
	3	1024 × 768	YUV422		×	×	×	×	×
	4	1024 × 768	RGB8			×	×	×	×
	5	1024 × 768	Mono8		× ×*	× ×*	× ×*	× ×*	× ×*
	6	800 × 600	Mono16		×	×	×	×	
2	0	1280 × 960	YUV422			×	×	×	×
	1	1280 × 960	RGB8			×	×	×	×
	2	1280 × 960	Mono8		× ×*	× ×*	× ×*	× ×*	× ×*
	3	1600 × 1200	YUV422						
	4	1600 × 1200	RGB8						
	5	1600 × 1200	Mono8						
	6	1280 × 960	Mono16			×	×	×	×
	7	1600 × 1200	Mono16						

Table 79: Video fixed formats Guppy PRO F-125B, F-125C

\*: Color camera outputs Mono8 interpolated image.

 Frame rates with shading are only achievable with IEEE1394b (S800).

### Note



The following table shows default Format\_7 modes without Format\_7 mode mapping.

- see [figure 58](#):
- see [Format\\_7 mode mapping \(only Guppy PRO F-503\)](#) on page 248

Format	Mode	Resolution	Color mode	Maximum S800 frame rates for Format_7 modes
7	0	1292 × 964	Mono8 Mono12 Mono16	31 fps 31 fps 26 fps
		1292 × 964	YUV411 YUV422,Raw16 Mono8,Raw8 RGB8 Raw12	31 fps 26 fps 31 fps 17 fps 31 fps
	1	644 × 964	Mono8 Mono12 Mono16	31 fps2x H-binning 31 fps2x H-binning 31 fps2x H-binning
	2	1292 × 482	Mono8 Mono12 Mono16	53 fps2x V-binning 53 fps2x V-binning 52 fps2x V-binning
	3	644 × 482	Mono8 Mono12 Mono16	53 fps2x H+V binning 53 fps2x H+V binning 53 fps2x H+V binning
	4	644 × 964	Mono8 Mono12 Mono16	31 fps2 out of 4 H-sub-sampling 31 fps2 out of 4 H-sub-sampling 31 fps2 out of 4 H-sub-sampling
	5 <sup>#</sup>	1292 × 482	Mono8 Mono12 Mono16	39 fps2 out of 4 V-sub-sampling 39 fps2 out of 4 V-sub-sampling 39 fps2 out of 4 V-sub-sampling
	6 <sup>#</sup>	644 × 482	Mono8 Mono12 Mono16	39 fps2 out of 4 H+V-sub-sampling 39 fps2 out of 4 H+V-sub-sampling 39 fps2 out of 4 H+V-sub-sampling

Table 80: Video Format\_7 default modes Guppy PRO F-125B, F-125C

#:Vertical sub-sampling is done via digitally concealing certain rows, so the frame rate is not  
 frame rate = f (AOI height)  
 but  
 frame rate = f (2 × AOI height)



## Guppy PRO F-146B, F-146C

Format	Mode	Resolution	Color mode	30 fps	15 fps	7.5 fps	3.75 fps	1.875 fps
0	0	160 × 120	YUV444					
	1	320 × 240	YUV422	×	×	×	×	×
	2	640 × 480	YUV411		×	×	×	×
	3	640 × 480	YUV422		×	×	×	×
	4	640 × 480	RGB8		×	×	×	×
	5	640 × 480	Mono8		× ×*	× ×*	× ×*	× ×*
	6	640 × 480	Mono16		×	×	×	×
1	0	800 × 600	YUV422		×	×	×	
	1	800 × 600	RGB8		×	×		
	2	800 × 600	Mono8		× ×*	× ×*		
	3	1024 × 768	YUV422		×	×	×	×
	4	1024 × 768	RGB8		×	×	×	×
	5	1024 × 768	Mono8		× ×*	× ×*	× ×*	× ×*
	6	800 × 600	Mono16		×	×	×	
	7	1024 × 768	Mono16		×	×	×	×
2	0	1280 × 960	YUV422		×	×	×	×
	1	1280 × 960	RGB8		×	×	×	×
	2	1280 × 960	Mono8		× ×*	× ×*	× ×*	× ×*
	3	1600 × 1200	YUV422					
	4	1600 × 1200	RGB8					
	5	1600 × 1200	Mono8					
	6	1280 × 960	Mono16		×	×	×	×
	7	1600 × 1200	Mono16					

Table 81: Video fixed formats Guppy PRO F-146B, F-146C

\*: Color camera outputs Mono8 interpolated image.

 Only achievable with IEEE1394b (S800).

### Note



The following table shows default Format\_7 modes without Format\_7 mode mapping.

- see [figure 58](#):
- see [Format\\_7 mode mapping \(only Guppy PRO F-503\)](#) on page 248

Format	Mode	Resolution	Color mode	Maximum S800 frame rates for Format_7 modes
7	0	1388 × 1038	Mono8	17 fps
			Mono12	17 fps
			Mono16	17 fps
		1388 × 1038	YUV411	17 fps
			YUV422,Raw16	17 fps
			Mono8,Raw8	17 fps
			RGB8	15 fps
	Raw12	17 fps		
1	692 × 1038	Mono8	17 fps2x H-binning	
		Mono12	17 fps2x H-binning	
Mono16		17 fps2x H-binning		
2	1388 × 518	Mono8	28 fps2x V-binning	
		Mono12	28 fps2x V-binning	
Mono16		28 fps2x V-binning		
3	692 × 518	Mono8	28 fps2x H+V binning	
		Mono12	28 fps2x H+V binning	
Mono16		28 fps2x H+V binning		
4	692 × 1038	Mono8	17 fps2 out of 4 H-sub-sampling	
		Mono12	17 fps2 out of 4 H-sub-sampling	
Mono16		17 fps2 out of 4 H-sub-sampling		
5 <sup>#</sup>	1388 × 518	Mono8	21 fps2 out of 4 V-sub-sampling	
		Mono12	21 fps2 out of 4 V-sub-sampling	
Mono16		21 fps2 out of 4 V-sub-sampling		
6 <sup>#</sup>	692 × 518	Mono8	21 fps2 out of 4 H+V-sub-sampling	
		Mono12	21 fps2 out of 4 H+V-sub-sampling	
Mono16		21 fps2 out of 4 H+V-sub-sampling		

Table 82: Video Format\_7 default modes Guppy PRO F-146B, F-146C

#:Vertical sub-sampling is done via digitally concealing certain rows, so the frame rate is not  
 frame rate = f (AOI height)  
 but  
 frame rate = f (2 × AOI height)

## Guppy PRO F-201B, F-201C

Format	Mode	Resolution	Color mode	30 fps	15 fps	7.5 fps	3.75 fps	1.875 fps
0	0	160 × 120	YUV444					
	1	320 × 240	YUV422	×	×	×	×	×
	2	640 × 480	YUV411	×	×	×	×	×
	3	640 × 480	YUV422	×	×	×	×	×
	4	640 × 480	RGB8	×	×	×	×	×
	5	640 × 480	Mono8	× ×*	× ×*	× ×*	× ×*	× ×*
	6	640 × 480	Mono16	×	×	×	×	×
1	0	800 × 600	YUV422		×	×	×	
	1	800 × 600	RGB8		×	×		
	2	800 × 600	Mono8		× ×*	× ×*		
	3	1024 × 768	YUV422		×	×	×	×
	4	1024 × 768	RGB8		×	×	×	×
	5	1024 × 768	Mono8		× ×*	× ×*	× ×*	× ×*
	6	800 × 600	Mono16		×	×	×	
	7	1024 × 768	Mono16		×	×	×	×
2	0	1280 × 960	YUV422		×	×	×	×
	1	1280 × 960	RGB8		×	×	×	×
	2	1280 × 960	Mono8		× ×*	× ×*	× ×*	× ×*
	3	1600 × 1200	YUV422			×	×	×
	4	1600 × 1200	RGB8			×	×	×
	5	1600 × 1200	Mono8			× ×*	× ×*	× ×*
	6	1280 × 960	Mono16		×	×	×	×
	7	1600 × 1200	Mono16			×	×	×

Table 83: Video fixed formats Guppy PRO F-201B, F-201C

\*: Color camera outputs Mono8 interpolated image.

 Only achievable with IEEE1394b (S800).

### Note

The following table shows default Format\_7 modes without Format\_7 mode mapping.



- see [Binning and sub-sampling access \(Guppy PRO F-503B, F-503C, and monochrome CCD models\)](#) on page 127
- see [table 53](#)

Format	Mode	Resolution	Color mode	Maximum S800 frame rates for Format_7 modes
7	0	1624 × 1234	Mono8 Mono12 Mono16	14 fps 14 fps 14 fps
		1624 × 1234	YUV411 YUV422,Raw16 Mono8,Raw8 RGB8 Raw12	14 fps 14 fps 14 fps 12 fps 14 fps
	1	812 × 1234	Mono8 Mono12 Mono16	14 fps2x H-binning 14 fps2x H-binning 14 fps2x H-binning
	2	1624 × 616	Mono8 Mono12 Mono16	24 fps2x V-binning 24 fps2x V-binning 24 fps2x V-binning
	3	812 × 616	Mono8 Mono12 Mono16	24 fps2x H+V binning 24 fps2x H+V binning 24 fps2x H+V binning
7	4	812 × 1234	Mono8 Mono12 Mono16	14 fps2 out of 4 H-sub-sampling 14 fps2 out of 4 H-sub-sampling 14 fps2 out of 4 H-sub-sampling
	5 <sup>#</sup>	1624 × 616	Mono8 Mono12 Mono16	17 fps2 out of 4 V-sub-sampling 17 fps2 out of 4 V-sub-sampling 17 fps2 out of 4 V-sub-sampling
	6 <sup>#</sup>	812 × 616	Mono8 Mono12 Mono16	17 fps2 out of 4 H+V sub-sampling 17 fps2 out of 4 H+V sub-sampling 17 fps2 out of 4 H+V sub-sampling

Table 84: Video Format\_7 default modes Guppy PRO F-201B, F-201C

#: Vertical sub-sampling is done via digitally concealing certain rows, so the frame rate is not

frame rate = f (AOI height)

but

frame rate = f (2 × AOI height)

## Guppy PRO F-503B, F-503C

F0M2 (120 fps), F0M5 (120 fps), F1M5 (60 fps) are only available with electronic rolling shutter (whereas present in both shutter modes). If using global reset release shutter the camera runs these modes with half frame rates only.

Format	Mode	Resolution	Color mode	120 fps	60 fps	30 fps	15 fps	7.5 fps	3.75 fps	1.875 fps
0	0	160 × 120	YUV444							
	1	320 × 240	YUV422	×	×	×	×	×	×	×
	2	640 × 480	YUV411	×	×	×	×	×	×	×
	3	640 × 480	YUV422		×	×	×	×	×	×
	4	640 × 480	RGB8							
	5	640 × 480	Mono8	× ×*	× ×*	× ×*	× ×*	× ×*	× ×*	× ×*
	6	640 × 480	Mono16		×	×	×	×	×	×
1	0	800 × 600	YUV422		×	×	×	×	×	
	1	800 × 600	RGB8							
	2	800 × 600	Mono8		× ×*	× ×*	× ×*	× ×*		
	3	1024 × 768	YUV422			×	×	×	×	×
	4	1024 × 768	RGB8							
	5	1024 × 768	Mono8		× ×*	× ×*	× ×*	× ×*	× ×*	× ×*
	6	800 × 600	Mono16		×	×	×	×	×	
2	0	1280 × 960	YUV422				×	×	×	×
	1	1280 × 960	RGB8							
	2	1280 × 960	Mono8			× ×*	× ×*	× ×*	× ×*	× ×*
	3	1600 × 1200	YUV422				×	×	×	×
	4	1600 × 1200	RGB8							
	5	1600 × 1200	Mono8				× ×*	× ×*	× ×*	× ×*
	6	1280 × 960	Mono16				×	×	×	×
	7	1600 × 1200	Mono16				×	×	×	×

Table 85: Video formats Guppy PRO F-503B, F-503C

\*: Color camera outputs Mono8 interpolated image.

 Only achievable with IEEE1394b (S800).

**Note**

The following table shows default Format\_7 modes without Format\_7 mode mapping.



- see [figure 58](#):
- see [Format\\_7 mode mapping \(only Guppy PRO F-503\)](#) on page 248

Format	Mode	Resolution	Color mode	Maximum S800 frame rates for Format_7 modes
7	0	2588 × 1940	Mono8 Mono12 Mono16	13.04 fps 8.69 fps 6.52 fps
		2588 × 1940	Mono8,Raw8 YUV411,Raw12 YUV422,Raw16	13.04 fps 8.69 fps 6.52 fps
		1292 × 1940	Mono8 Mono12 Mono16	22.76 fps2x H-binning 17.41 fps2x H-binning 13.06 fps2x H-binning
	1	1292 × 1944	Mono8,Raw8 YUV411,Raw12 YUV422,Raw16	22.76 fps2x H-binning 17.41 fps2x H-binning 13.06 fps2x H-binning
		2588 × 968	Mono8 Mono12 Mono16	23.36 fps2x V-binning 17.41 fps2x V-binning 13.06 fps2x V-binning
	2	2588 × 968	Mono8,Raw8 YUV411,Raw12 YUV422,Raw16	23.36 fps2x V-binning 17.41 fps2x V-binning 13.06 fps2x V-binning
		1292 × 968	Mono8 Mono12 Mono16	34.26 fps2x H+V binning 34.26 fps2x H+V binning 26.10 fps2x H+V binning
	3	1292 × 968	Mono8,Raw8 YUV411,Raw12 YUV422,Raw16	34.26 fps2x H+V binning 34.26 fps2x H+V binning 26.10 fps2x H+V binning
		1292 × 1940	Mono8 Mono12 Mono16	22.32 fps2x H-sub-sampling 17.41 fps2x H-sub-sampling 13.06 fps2x H-sub-sampling
	4	1292 × 1940	Mono8,Raw8 YUV411,Raw12 YUV422,Raw16	22.32 fps2x H-sub-sampling 17.41 fps2x H-sub-sampling 13.06 fps2x H-sub-sampling

Table 86: Video Format\_7 default modes Guppy PRO F-503B, F-503C

Format	Mode	Resolution	Color mode	Maximum S800 frame rates for Format_7 modes
7	5	2588 × 968	Mono8	26.10 fps2x V-sub-sampling
			Mono12	17.41 fps2x V-sub-sampling
			Mono16	13.06 fps2x V-sub-sampling
	2588 × 968	Mono8,Raw8	26.10 fps2x V-sub-sampling	
		YUV411,Raw12	17.41 fps2x V-sub-sampling	
		YUV422,Raw16	13.06 fps2x V-sub-sampling	
6	1292 × 968	Mono8	44.32 fps2x H+V sub-sampling	
		Mono12	34.71 fps2x H+V sub-sampling	
		Mono16	26.10 fps2x H+V sub-sampling	
	1292 × 968	Mono8,Raw8	44.32 fps2x H+V sub-sampling	
		YUV411,Raw12	34.71 fps2x H+V sub-sampling	
		YUV422,Raw16	26.10 fps2x H+V sub-sampling	

Table 86: Video Format\_7 default modes Guppy PRO F-503B, F-503C (continued)

## Area of interest (AOI)

The camera's image sensor has a defined resolution. This indicates the maximum number of rows and pixels per row that the recorded image may have.

However, often only a certain section of the entire image is of interest. The amount of data to be transferred can be decreased by limiting the image to a section when reading it out from the camera. At a lower vertical resolution the sensor can be read out faster and thus the frame rate is increased.

**Note** The setting of AOIs is supported only in video Format\_7.



While the size of the image read out for most other video formats and modes is fixed by the IIDC specification, thereby determining the highest possible frame rate, in Format\_7 mode the user can set the upper left corner and width and height of the section (area of interest = AOI) he is interested in to determine the size and thus the highest possible frame rate.

Setting the AOI is done in the IMAGE\_POSITION and IMAGE\_SIZE registers.

**Note** Pay attention to the increments entering in the UNIT\_SIZE\_INQ and UNIT\_POSITION\_INQ registers when configuring IMAGE\_POSITION and IMAGE\_SIZE.



AF\_AREA\_POSITION and AF\_AREA\_SIZE contain in the respective bits values for the column and row of the upper left corner and values for the width and height.

**Note** For more information see [table 120](#):

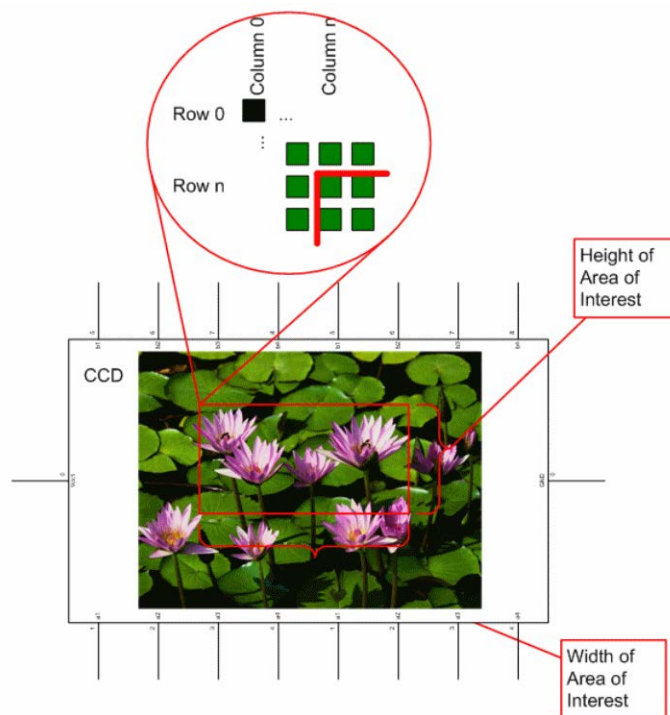

Figure 71: Area of interest (AOI)

**Note**



- The left position + width and the upper position + height may not exceed the maximum resolution of the sensor.
- The coordinates for width and height must be divisible by 4.

In addition to the area of interest (AOI), some other parameters have an effect on the maximum frame rate:

- The time for reading the image from the sensor and transporting it into the FRAME\_BUFFER
- The time for transferring the image over the FireWire™ bus
- The length of the exposure time.



## Autofunction AOI

Use this feature to select the image area (work area) on which the following autofunctions work:

- Auto shutter
- Auto gain
- Auto white balance

In the following screenshot you can see an example of the autofunction AOI.

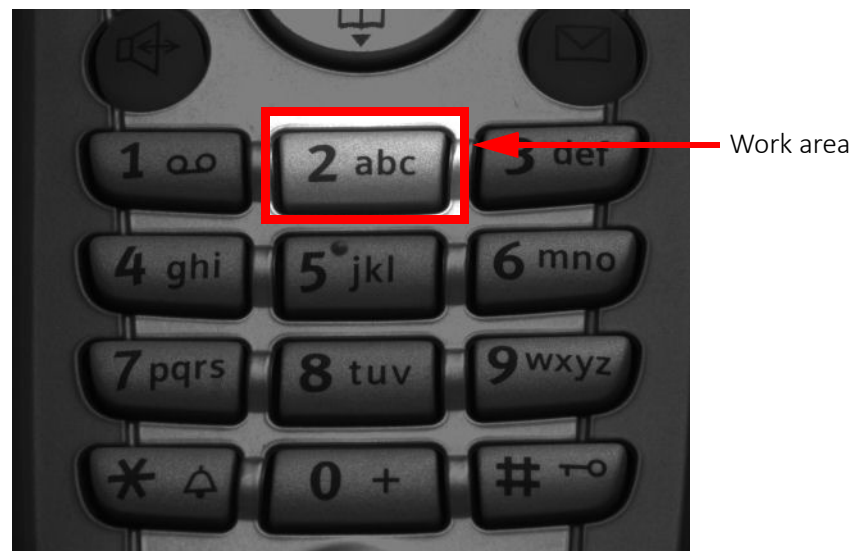

Figure 72: Example of autofunction AOI (Show work area is on)

### Note



Autofunction AOI is independent from Format\_7 AOI settings.

If you switch off autofunction AOI, work area position and work area size follow the current active image size.

To switch off autofunctions, carry out following actions in the order shown:

1. Uncheck **Show AOI** check box (SmartView Ctrl2 tab).
2. Uncheck **Enable** check box (SmartView Ctrl2 tab).  
Switch off Auto modes (e.g. Shutter and/or Gain) (SmartView Ctrl2 tab).

As a reference it uses a grid of up to 65534 sample points equally spread over the AOI.

### Note



Configuration

To configure this feature in an advanced register see [Autofunction AOI](#) on page 242.

## Frame rates

An IEEE1394 camera requires bandwidth to transport images.

The IEEE1394b bus has very large bandwidth of at least 62.5 MByte/s for transferring (isochronously) image data. Per cycle up to 8192 bytes (or around 2000 quadlets = 4 bytes@ 800 Mbit/s) can thus be transmitted.

**Note** All bandwidth data is calculated with:



1 MByte = 1024 kByte

Depending on the video format settings and the configured frame rate, the camera requires a certain percentage of maximum available bandwidth. Clearly the bigger the image and the higher the frame rate, the more data is to be transmitted.

The following tables indicate the volume of data in various formats and modes to be sent within one cycle (125  $\mu$ s) at 800 Mbit/s of bandwidth.

The tables are divided into three formats:

Format	Resolution	Max. video format
Format_0	up to VGA	640 × 480
Format_1	up to XGA	1024 × 768
Format_2	up to UXGA	1600 × 1200

*Table 87: Overview fixed formats*

They enable you to calculate the required bandwidth and to ascertain the number of cameras that can be operated independently on a bus and in which mode.

Format	Mode	Resolution	240 fps	120 fps	60 fps	30 fps	15 fps	7.5 fps	3.75 fps
0	0	160 × 120 YUV (4:4:4) 24 bit/pixel	4H 640p 480q	2H 320p 240q	1H 160p 120q	1/2H 80p 60q	1/4H 40p 30q	1/8H 20p 15q	
	1	320 × 240 YUV (4:2:2) 16 bit/pixel	8H 2560p 1280q	4H 1280p 640q	2H 640p 320q	1H 320p 160q	1/2H 160p 80q	1/4H 80p 40q	1/8H 40p 20q
	2	640 × 480 YUV (4:1:1) 12-bit/pixel		8H 5120p 1920q	4H 2560p 960q	2H 1280p 480q	1H 640p 240q	1/2H 320p 120q	1/4H 160p 60q
	3	640 × 480 YUV (4:2:2) 16 bit/pixel			4H 2560p 1280q	2H 1280p 640q	1H 640p 320q	1/2H 320p 160q	1/4H 160p 80q
	4	640 × 480 RGB 24 bit/pixel			4H 2560p 1280q	2H 1280p 960q	1H 640p 480q	1/2H 320p 240q	1/4H 160p 120q
	5	640 × 480 (Mono8) 8 bit/pixel		8H 5120p 1280q	4H 2560p 640q	2H 1280p 320q	1H 640p 160q	1/2H 320p 80q	1/4H 160p p40q
	6	640 × 480 Y (Mono16) 16 bit/pixel			4H 2560p 1280q	2H 1280p 640q	1H 640p 320q	1/2H 320p 160q	1/4H 160p 80q
	7	Reserved							

Table 88: Format\_0

As an example, VGA Mono8 @ 60 fps requires four rows ( $640 \times 4 = 2560$  pixels/byte) to transmit every  $125 \mu\text{s}$ : this is a consequence of the sensor's row time of about  $30 \mu\text{s}$ , so that no data needs to be stored temporarily.

It takes 120 cycles ( $120 \times 125 \mu\text{s} = 15 \text{ms}$ ) to transmit one frame, which arrives every 16.6 ms from the camera. Again, no data need to be stored temporarily.

Thus around 64% of the available bandwidth (at S400) is used. Thus one camera can be connected to the bus at S400.

The same camera, run at S800 would require only 32% of the available bandwidth, due to the doubled speed. Thus up to three cameras can be connected to the bus at S800.

Format	Mode	Resolution	240 fps	120 fps	60 fps	30 fps	15 fps	7.5 fps	3.75 fps	1.875 fps
1	0	800 × 600 YUV (4:2:2) 16 bit/pixel			5H 4000p 2000q	5/2H 2000p 1000q	5/4H 1000p 500q	5/8H 500p 250q	6/16H 250p 125q	
	1	800 × 600 RGB 24 bit/pixel				5/2H 2000p 1500q	5/4H 1000p 750q	5/8H 500p 375q		
	2	800 × 600 Y (Mono8) 8 bit/pixel		10H 8000p 2000q	5H 4000p 1000q	5/2H 2000p 500q	5/4H 1000p 250q	5/8H 500p 125q		
	3	1024 × 768 YUV (4:2:2) 16 bit/pixel				3H 3072p 1536q	3/2H 1536p 768q	3/4H 768p 384q	3/8H 384p 192q	3/16H 192p 96q
	4	1024 × 768 RGB 24 bit/pixel					3/2H 1536p 384q	3/4H 768p 576q	3/8H 384p 288q	3/16H 192p 144q
	5	1024 × 768 Y (Mono) 8 bit/pixel			6H 6144p 1536q	3H 3072p 768q	3/2H 1536p 384q	3/4H 768p 192q	3/8H 384p 96q	3/16H 192p 48q
	6	800 × 600 (Mono16) 16 bit/pixel			5H 4000p 2000q	5/2H 2000p 1000q	5/4H 1000p 500q	5/8H 500p 250q	5/16H 250p 125q	
	7	1024 × 768 Y (Mono16) 16 bit/pixel				3H 3072p 1536q	3/2H 1536p 768q	3/4H 768p 384q	3/8H 384p 192q	3/16H 192p 96q

Table 89: Format\_1

Format	Mode	Resolution	60 fps	30 fps	15 fps	7.5 fps	3.75 fps	1.875 fps
2	0	1280 × 960 YUV (4:2:2) 16 bit/pixel			2H 2560p 1280q	1H 1280p 640q	1/2H 640p 320q	1/4H 320p 160q
	1	1280 × 960 RGB 24 bit/pixel			2H 2560p 1920q	1H 1280p 960q	1/2H 640p 480q	1/4H 320p 240q
	2	1280 × 960 Y (Mono8) 8 bit/pixel		4H 5120p 1280q	2H 2560p 640q	1H 1280p 320q	1/2H 640p 160q	1/4H 320p 80q
	3	1600 × 1200 YUV(4:2:2) 16 bit/pixel			5/2H 4000p 2000q	5/4H 2000p 1000q	5/8H 1000p 500q	5/16H 500p 250q
	4	1600 × 1200 RGB 24 bit/pixel				5/4H 2000p 1500q	5/8H 1000p 750q	5/16 500p 375q
	5	1600 × 1200 Y (Mono) 8 bit/pixel		5H 8000p 2000q	5/2H 4000p 1000q	5/4H 2000p 500q	5/8H 1000p 250q	5/16H 500p 125q
	6	1280 × 960 Y (Mono16) 16 bit/pixel			2H 2560p 1280q	1H 1280p 640q	1/2H 640p 320q	1/4H 320p 160q
	7	1600 × 1200Y(Mono16) 16 bit/pixel			5/2H 4000p 2000q	5/4H 2000p 1000q	5/8H 1000p 500q	5/16H 500p 250q

Table 90: Format\_2

As already mentioned, the recommended limit for transferring isochronous image data is 2000q (quadlets) per cycle or 8192 bytes (with 800 Mbit/s of bandwidth).

**Note**

- If the cameras are operated with an external trigger the maximum trigger frequency may not exceed the highest continuous frame rate, so preventing frames from being dropped or corrupted.
- IEEE1394 adapter cards with PCILynx™ chipsets (predecessor of OHCI) have a limit of 4000 bytes per cycle.

The frame rates in video modes 0 to 2 are specified and set fixed by IIDC V1.31.

## Frame rates Format\_7

In video Format\_7 frame rates are no longer fixed.

### Note



- Different values apply for the different sensors.
- Frame rates may be further limited by longer shutter times and/or bandwidth limitation from the IEEE1394 bus.

Details are described in the next chapters:

- Max. frame rate of CCD (theoretical formula)
- Diagram of frame rates as function of AOI by constant width:  
The curves describe RAW8, RAW12/YUV411, RAW16/YUV422, RGB8 and max. frame rate of CCD
- Table with max. frame rates as function of AOI by constant width

### Guppy PRO F-031: AOI frame rates

$$\text{max. frame rate of CCD} = \frac{1}{148.71\mu\text{s} + \text{AOI height} \times 16.05\mu\text{s} + (508 - \text{AOI height}) \times 2.93\mu\text{s}}$$

Formula 9: Theoretical max. frame rate of CCD

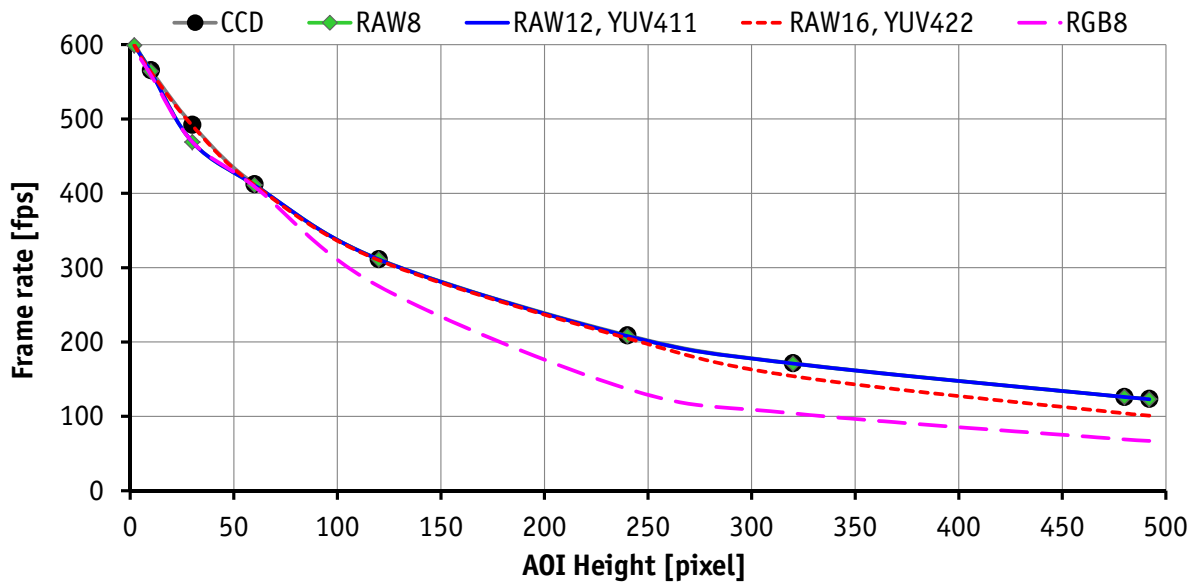

Figure 73: Frame rates as function of AOI height [width=656]

AOI height	CCD*	RAW8	RAW12	RAW16	YUV411	YUV422	RGB8
492	123.58	123	123	101	123	101	67
480	126.03	126	126	104	126	104	69
320	171.36	171	171	154	171	154	104
240	208.94	208	208	205	208	205	137
120	311.38	311	311	310	310	309	275
60	412.48	411	411	411	410	409	409
30	492.43	469	469	491	469	488	469
10	565.50	564	564	563	560	559	559
2	601.18	599	599	599	594	594	594

Table 91: Frame rates as function of AOI height [width=656]

\* CCD = theoretical max. frame rate (in fps) of CCD according to given formula

### Guppy PRO F-032: AOI frame rates

$$\text{max. frame rate of CCD} = \frac{1}{167.06\mu\text{s} + \text{AOI height} \times 24.31\mu\text{s} + (492 - \text{AOI height}) \times 2.97\mu\text{s}}$$

Formula 10: Theoretical max. frame rate of CCD

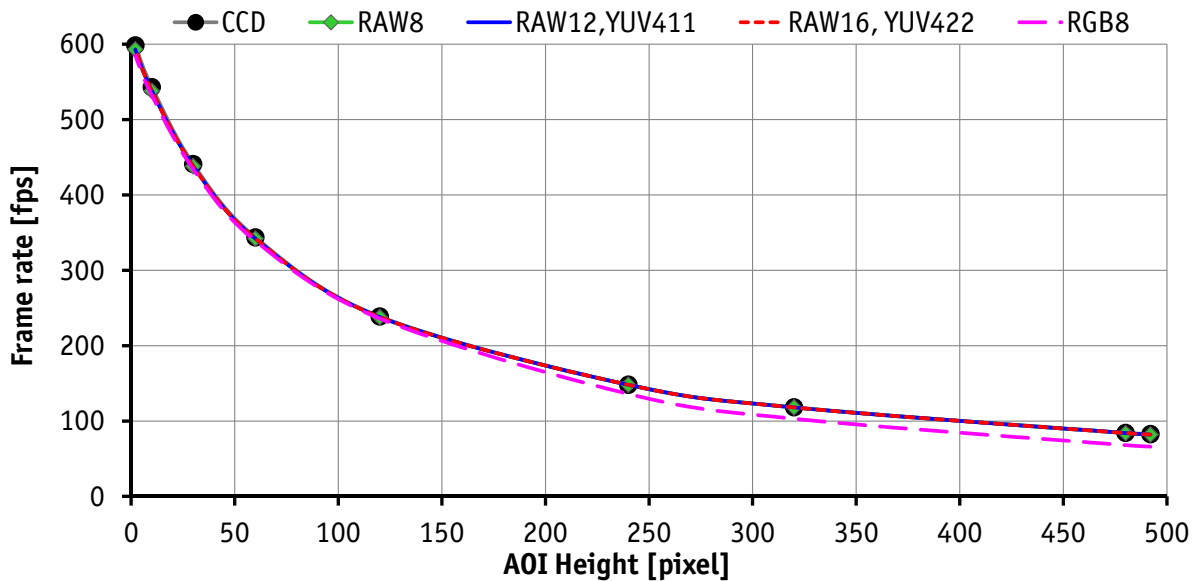

Figure 74: Frame rates as function of AOI height [width=656]

AOI height	CCD*	RAW8	RAW12	RAW16	YUV411	YUV422	RGB8
492	82.46	82	82	82	82	82	66
480	84.24	84	84	84	83	83	68
320	118.24	118	118	118	118	118	103
240	148.15	148	148	148	146	146	136
120	238.71	238	238	238	236	236	236
60	343.80	342	342	342	339	339	339
30	440.82	438	438	438	434	434	434
10	542.98	538	538	538	532	532	532
2	598.45	593	593	593	585	585	585

Table 92: Frame rates of as function of AOI height [width=656]

\* CCD = theoretical max. frame rate (in fps) of CCD according to given formula



### Guppy PRO F-033: AOI frame rates

$$\text{max. frame rate of CCD} = \frac{1}{186.50\mu\text{s} + \text{AOI height} \times 23.41\mu\text{s} + (505 - \text{AOI height}) \times 2.59\mu\text{s}}$$

Formula 11: Theoretical max. frame rate of CCD

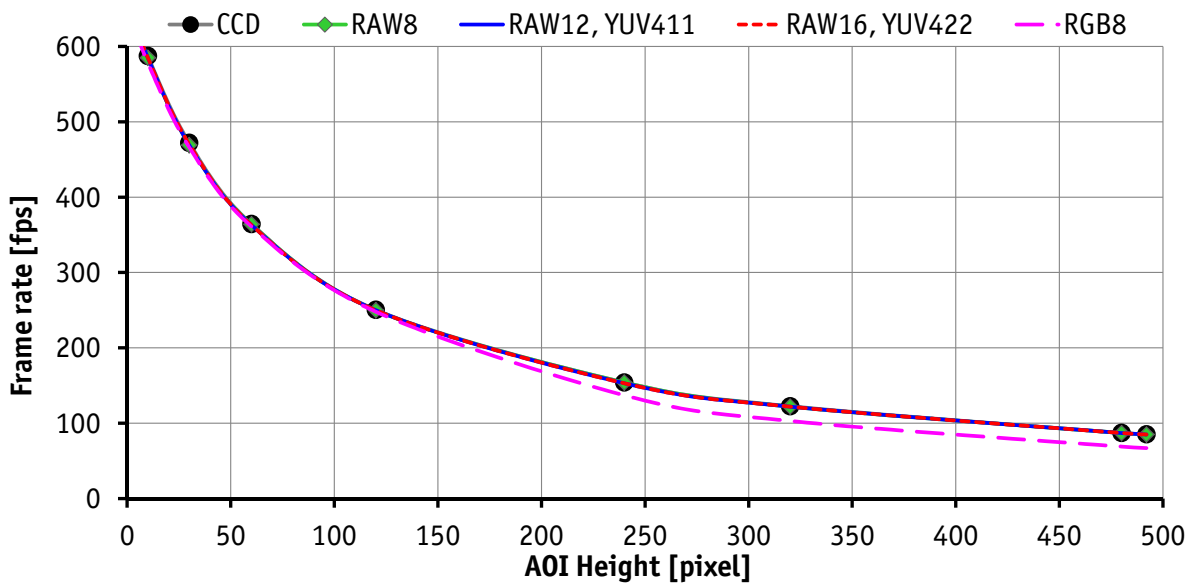

Figure 75: Frame rates as function of AOI height [width=656]

AOI height	CCD*	RAW8	RAW12	RAW16	YUV411	YUV422	RGB8
492	85.19	85	85	85	85	85	67
480	87.04	87	87	87	87	87	69
320	122.59	122	122	122	122	122	103
240	154.05	154	153	153	153	153	137
120	250.44	250	250	250	248	248	248
60	364.47	364	363	363	361	361	361
30	471.91	469	469	470	466	466	466
10	587.32	585	585	585	578	578	578
2	651.00	648	648	648	640	640	640

Table 93: Frame rates as function of AOI height [width=656]

\* CCD = theoretical max. frame rate (in fps) of CCD according to given formula

### Guppy PRO F-046: AOI frame rates

$$\text{max. frame rate of CCD} = \frac{1}{206.20\mu\text{s} + \text{AOI height} \times 27.35\mu\text{s} + (593 - \text{AOI height}) \times 2.59\mu\text{s}}$$

Formula 12: Theoretical max. frame rate of CCD

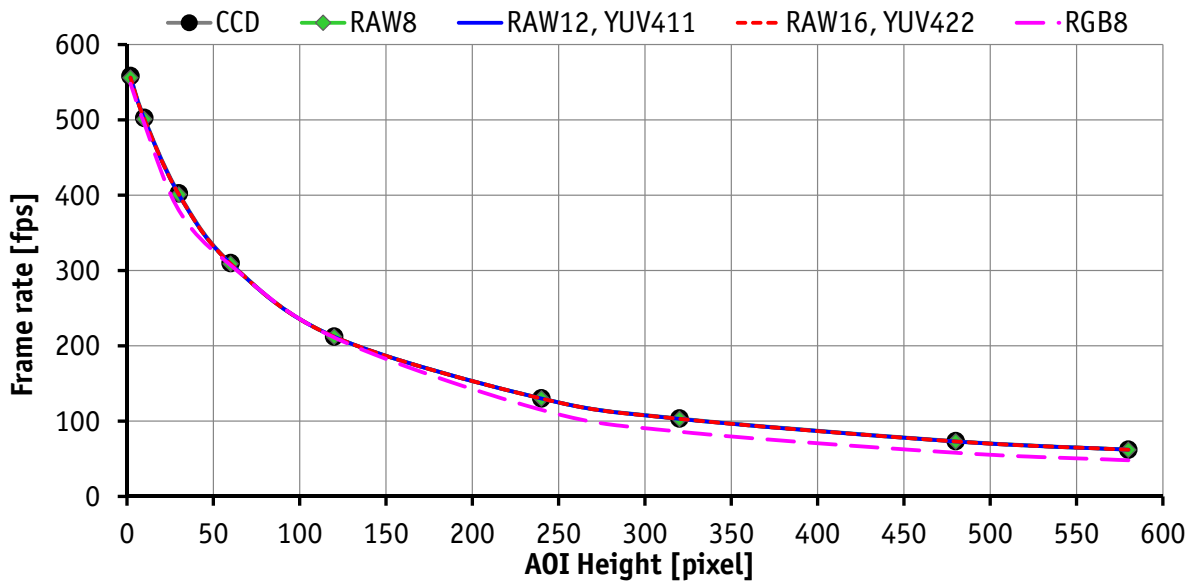

Figure 76: Frame rates as function of AOI height [width=780]

AOI height	CCD*	RAW8	RAW12	RAW16	YUV411	YUV422	RGB8
580	62.10	62	62	62	62	62	48
480	73.38	73	73	73	73	73	58
320	103.46	103	103	103	103	103	86
240	130.13	130	130	130	129	129	115
120	212.17	212	212	212	211	211	211
60	309.82	309	309	309	307	307	307
30	402.44	401	401	401	397	397	380
10	502.60	501	501	501	495	495	495
2	558.16	556	556	556	548	548	548

Table 94: Frame rates as function of AOI height [width=780]

\* CCD = theoretical max. frame rate (in fps) of CCD according to given formula

### Guppy PRO F-125: AOI frame rates

$$\text{max. frame rate of CCD} = \frac{1}{189.28\mu\text{s} + \text{AOI height} \times 33.19\mu\text{s} + (978 - \text{AOI height}) \times 5.03\mu\text{s}}$$

Formula 13: Theoretical max. frame rate of CCD

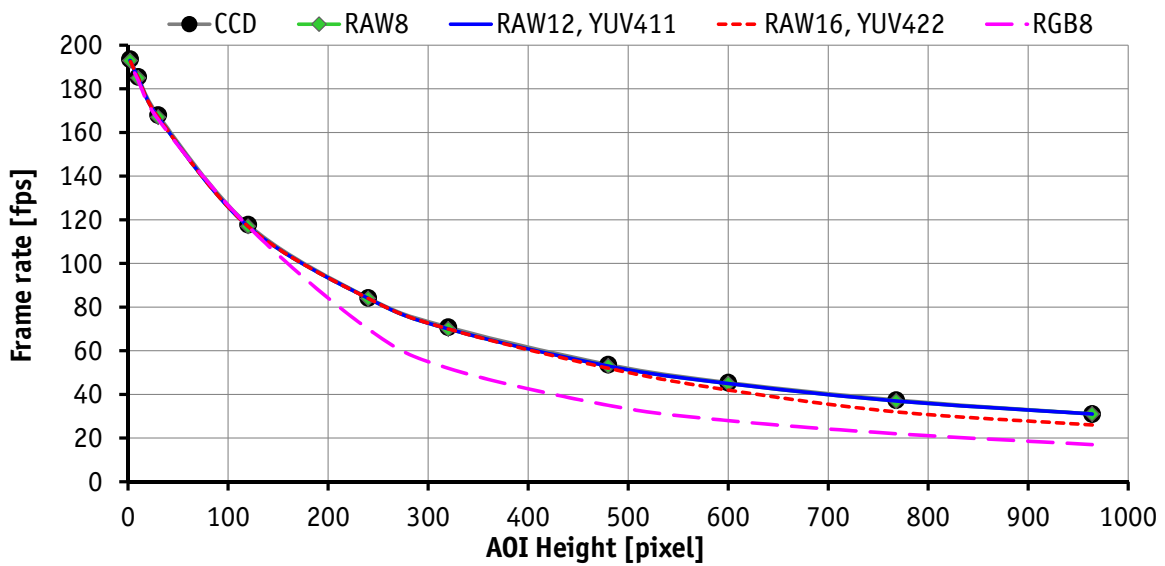

Figure 77: Frame rates as function of AOI height [width=1292]

AOI height	CCD*	RAW8	RAW12	RAW16	YUV411	YUV422	RGB8
964	31.00	31	31	26	31	26	17
768	37.40	37	37	32	37	32	22
600	45.45	45	45	42	45	42	28
480	53.69	53	53	52	53	52	35
320	70.82	70	70	70	70	70	52
240	84.27	84	84	84	84	84	70
120	117.82	117	117	117	117	117	117
30	167.97	167	167	167	166	166	166
10	185.52	185	185	185	184	184	184
2	193.61	193	193	193	192	192	192

Table 95: Frame rates as function of AOI height [width=1292]

\* CCD = theoretical max. frame rate (in fps) of CCD according to given formula (color modes: measured values)

### Guppy PRO F-146: AOI frame rates

$$\text{max. frame rate of CCD} = \frac{1}{73.06\mu\text{s} + \text{AOI height} \times 56.07\mu\text{s} + (1051 - \text{AOI height}) \times 11.55\mu\text{s}}$$

Formula 14: Theoretical max. frame rate of CCD

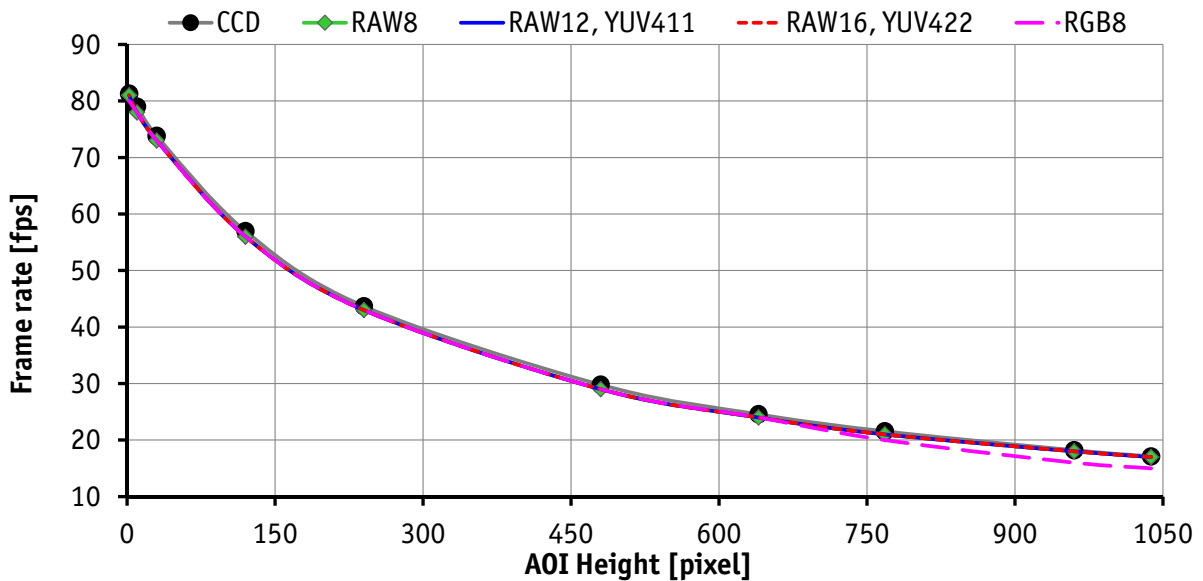

Figure 78: Frame rates as function of AOI height [width=1388]

AOI height	CCD*	RAW8	RAW12	RAW16	YUV411	YUV422	RGB8
1038	17.12	17	17	17	17	17	15
960	18.20	18	18	18	18	18	16
768	21.55	21	21	21	21	21	20
640	24.57	24	24	24	24	24	24
480	29.78	29	29	29	29	29	29
240	43.67	43	43	43	43	43	43
120	56.96	56	56	56	56	56	56
30	73.81	73	73	73	73	73	73
10	79.01	78	78	78	78	78	78
2	81.29	81	81	81	80	80	80

Table 96: Frame rates as function of AOI height [width=1388]

\* CCD = theoretical max. frame rate (in fps) of CCD according to given formula (color modes: measured values)

### Guppy PRO F-201: AOI frame rates

$$\text{max. frame rate of CCD} = \frac{1}{344.90\mu\text{s} + \text{AOI height} \times 57.50\mu\text{s} + (1238 - \text{AOI height}) \times 8.2\mu\text{s}}$$

Formula 15: Theoretical max. frame rate of CCD

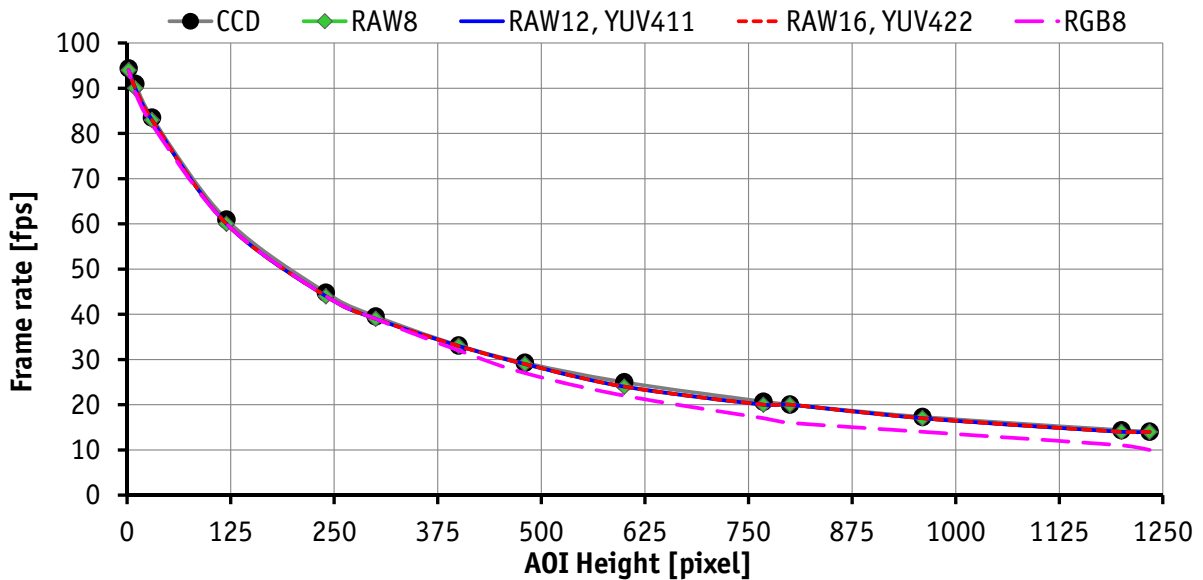

Formula 16: Frame rates as function of AOI height [width=1624]

AOI height	CCD*	RAW8	RAW12	RAW16	YUV411	YUV422	RGB8
1234	14.02	14	14	14	14	14	11
1200	14.36	14	14	14	14	14	11
960	17.29	17	17	17	17	17	14
800	20.03	20	20	20	20	20	16
768	20.68	20	20	20	20	20	17
600	24.95	24	24	24	24	24	22
480	29.27	29	29	29	29	29	27
400	33.09	33	33	33	32	32	32
300	39.55	39	39	39	39	39	39
240	44.79	44	44	44	44	44	44
120	60.93	60	60	60	60	60	60
30	83.50	83	83	83	82	82	82
10	91.00	90	90	90	90	89	89
2	94.38	94	94	94	94	94	92

Table 97: Frame rates of as function of AOI height [width=1624]

\* CCD = theoretical max. frame rate of CCD according to given formula (color modes: measured values)

### Guppy PRO F-503: AOI frame rates

$$\text{max. frame rate of CMOS} = \frac{1}{(\text{AOI height} + 9) \times t_{\text{row}}}$$

Formula 17: Theoretical max. frame rate of CMOS (min. shutter, no binning, no sub-sampling). For calculating  $t_{\text{row}}$ , see [Exposure time of Guppy PRO F-503](#) on page 149

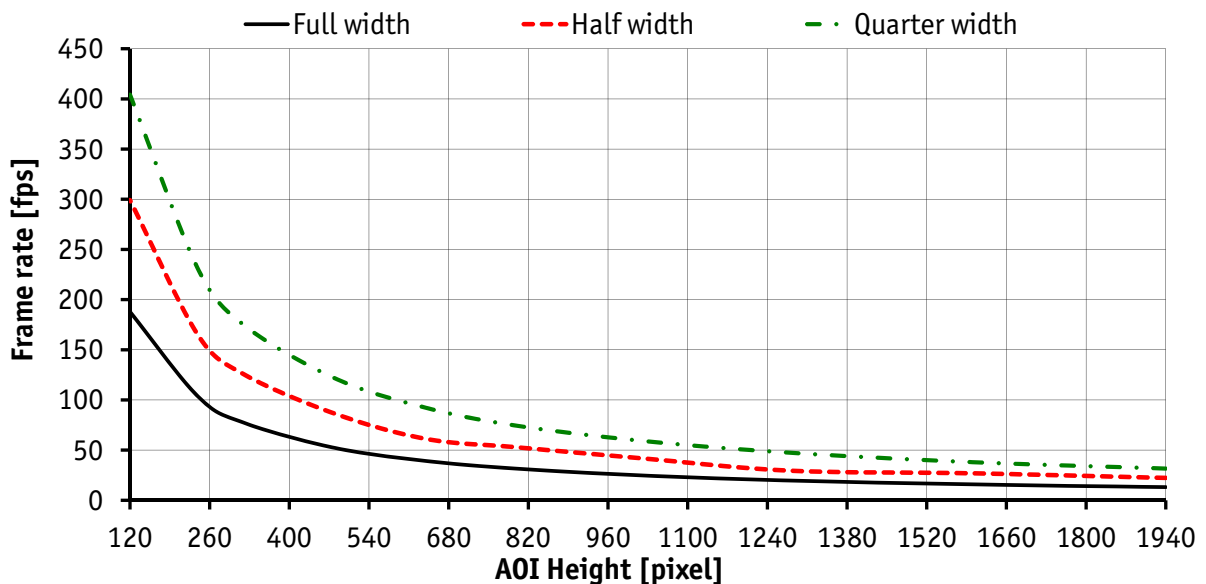

Figure 79: Frame rates as function of AOI height and AOI width (full/half/quarter)

The frame rates in the following table are measured directly at the output of the camera (rolling shutter, Raw format). Compare with [How does bandwidth affect the frame rate?](#) on page 192.

AOI height / pixel	Frame rate / fps full width	Frame rate / fps half width	Frame rate / fps quarter width
1940	13.1	22.3	31.6
1600	15.8	26.9	38.0
1280	19.7	29.5	47.4

Table 98: Frame rates as function of AOI height and AOI width (full/half/quarter)

AOI height / pixel	Frame rate / fps full width	Frame rate / fps half width	Frame rate / fps quarter width
1024	24.6	41.6***	59.0
800	31.5	52.8**	74.3
640	39.2	61.2	92.2
480	52.2	86.3	121.6
320	77.3	125.6	174.7
240	103.2	164.2	230.0
120	187.9*	299.1	404.2

Table 98: Frame rates as function of AOI height and AOI width (full/half/quarter) (continued)

\*Max. packet size 7760

\*\* Max. packet size 6980

\*\*\*Max. packet size 6960

**Note**



The minimum AOI of Guppy F-503 is 64 × 64 (AOI width × AOI height).

The readout time for one row is not constant. It varies with AOI width.

## How does bandwidth affect the frame rate?

In some modes the IEEE1394b bus limits the attainable frame rate. According to the 1394b specification on isochronous transfer, the largest data payload size of 8192 bytes per 125  $\mu$ s cycle is possible with bandwidth of 800 Mbit/s. In addition, there is a limitation, only a maximum number of 65535 ( $2^{16} - 1$ ) packets per frame are allowed.

**Note** Certain cameras may offer higher packet sizes, depending on their settings in combination with the use of FirePackage.



Consult your local dealer's support team, if you require additional information on this feature.

The following formula establishes the relationship between the required Byte\_Per\_Packet size and certain variables for the image. It is valid only for Format\_7.

$$\text{BYTE\_PER\_PACKET} = \text{frame rate} \times \text{AOI\_WIDTH} \times \text{AOI\_HEIGHT} \times \text{ByteDepth} \times 125 \mu\text{s}$$

*Formula 18: Byte\_per\_Packet calculation (only Format\_7)*

If the value for BYTE\_PER\_PACKET is greater than 8192 (the maximum data payload), the sought-after frame rate cannot be attained.

The attainable frame rate can be calculated using this formula:

(Provision: BYTE\_PER\_PACKET is divisible by 4):

$$\text{frame rate} \approx \frac{\text{BYTE\_PER\_PACKET}}{\text{AOI\_WIDTH} \times \text{AOI\_HEIGHT} \times \text{ByteDepth} \times 125 \mu\text{s}}$$

*Formula 19: Maximum frame rate calculation*

ByteDepth is based on the following values:

Mode	bit/pixel	byte per pixel
Mono8, Raw8	8	1
Mono12, Raw12	12	1.5
Mono16, Raw16	14	2
YUV4:2:2	16	2
RGB8	24	3

*Table 99: ByteDepth*



**Example formula for the monochrome camera**

Mono16, 1392 × 1040, 30 fps desired

$$\text{BYTE\_PER\_PACKET} = 30 \times 1392 \times 1040 \times 2 \times 125\mu\text{s} = 10856 > 8192$$

$$\Rightarrow \text{frame rate}_{\text{reachable}} \approx \frac{8192}{1392 \times 1040 \times 2 \times 125\mu\text{s}} = 22.64$$

*Formula 20: Example maximum frame rate calculation*

## Test images

### Loading test images

FirePackage	Fire4Linux
<ol style="list-style-type: none"> <li>1. Start SmartView.</li> <li>2. Click the Edit settings button. </li> <li>3. Click Adv1 tab.</li> <li>4. In combo box Test images choose Image 1 or another test image.</li> </ol>	<ol style="list-style-type: none"> <li>1. Start cc1394 viewer.</li> <li>2. In Adjustments menu click on Picture Control.</li> <li>3. Click Main tab.</li> <li>4. Activate Test image check box on.</li> <li>5. In combo box Test images choose Image 1 or another test image.</li> </ol>

*Table 100: Loading test images in different viewers*

### Test images for monochrome models

Guppy PRO monochrome cameras have two test images that look the same. Both images show a gray bar running diagonally (mirrored at the middle axis).

- Image 1 is static.
- Image 2 moves upwards by 1 pixel/frame.

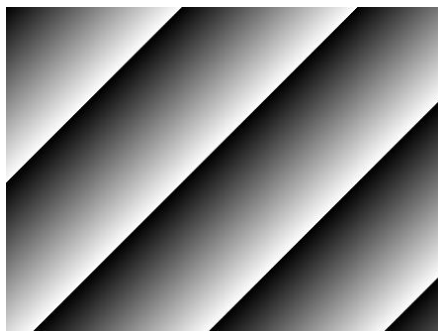
*Figure 80: gray bar test image*

## Test images for color models

The color cameras have 1 test image:

### YUV4:2:2 mode

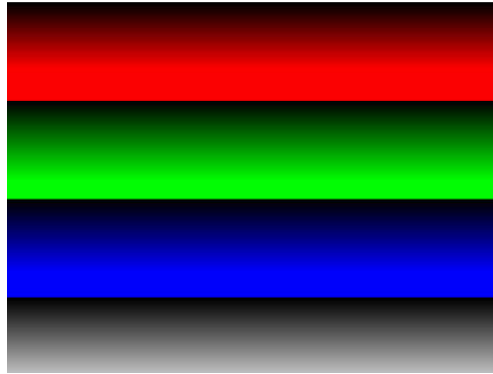

*Figure 81: Color test image*

### Mono8 (raw data)

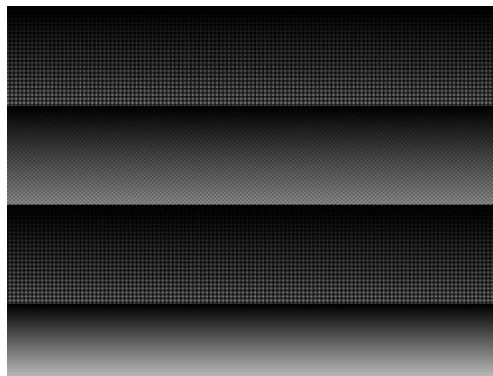

*Figure 82: Bayer-coded test image*

The color camera outputs Bayer-coded raw data in Mono8 instead of (as described in IIDC V1.31) a real Y signal.

**Note** The first pixel of the image is always the red pixel from the sensor. (Mirror must be switched off.)



# Configuration of the camera

All camera settings are made by writing specific values into the corresponding registers.

This applies to:

- values for general operating states such as video formats and modes, exposure times, etc.
- extended features of the camera that are turned on and off and controlled via corresponding registers (so-called advanced registers).

## Camera\_Status\_Register

The interoperability of cameras from different manufacturers is ensured by IIDC, formerly DCAM (Digital Camera Specification), published by the IEEE1394 Trade Association.

IIDC is primarily concerned with setting memory addresses (e.g. CSR: Camera\_Status\_Register) and their meaning.

In principle all addresses in IEEE1394 networks are 64 bits long.

The first 10-bits describe the Bus\_Id, the next 6 bits the Node\_Id.

Of the subsequent 48 bit, the first 16 bit are always FFFFh, leaving the description for the Camera\_Status\_Register in the last 32 bit.

If a CSR F0F00600h is mentioned below this means in full:

Bus\_Id, Node\_Id, FFFF F0F00600h

Writing and reading to and from the register can be done with programs such as FireView or by other programs developed using an API library (e.g. FirePackage).<sup>10</sup> Every register is 32 bit (big endian) and implemented as follows (MSB = Most Significant Bit; LSB = Least Significant Bit):

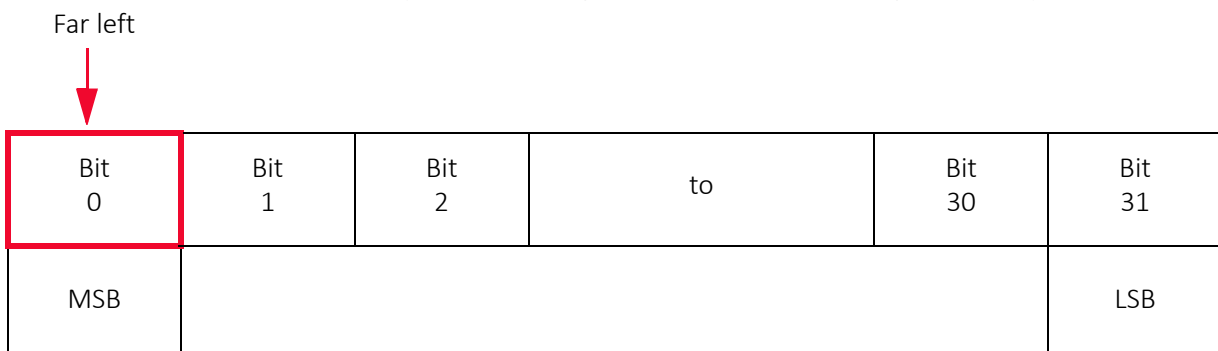
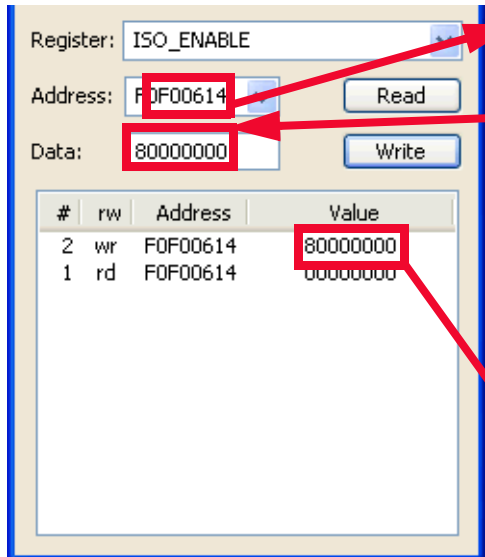

Table 101: 32-bit register

### Example

This requires, for example, that to enable ISO\_Enabled mode (see chapter [ISO\\_Enabled / free-run](#) on page 155), (bit 0 in register 614h), the value 80000000 h must be written in the corresponding register.



Offset of Register: (0x0F00614)  
ISO\_Enabled

Write 80000000 and click **Write**

#	rw	Address	Value
2	wr	F0F00614	80000000
1	rd	F0F00614	00000000

Content of register: 80000000  
= 1000 0000 0000 0000 0000 0000 0000 0000

Figure 83: Enabling ISO\_Enabled

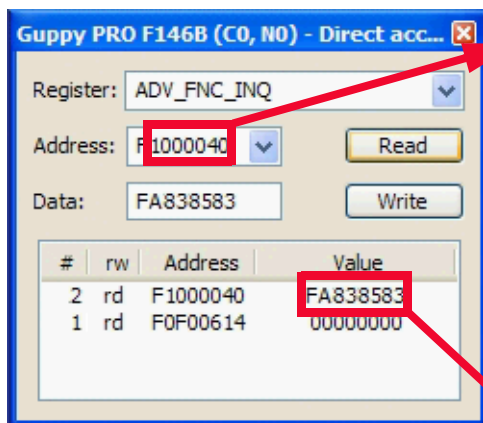

Offset of Register: (0xF100040)  
ADV\_FNC\_INQ

Content of register: FA838583  
= 1111 1010 1000 0011 1000 0101 1000 0011

#	rw	Address	Value
2	rd	F1000040	FA838583
1	rd	F0F00614	00000000

Table 102: Configuring the camera (Guppy PRO F-146B)

	MaxResolution	TimeBase	ExtdShutter	Testimage		VersionInfo		Look-up tables						Trigger Delay	Misc. features	
Bit	0	1	2	3	4	5	6	7	8	9	10	11	12	13	14	15
	1	1	1	1	1	0	1	0	1	0	0	0	0	0	1	1
	SoftReset				UserProfiles								GP_Buffer			
Bit	16	17	18	19	20	21	22	23	24	25	26	27	28	29	30	31
	1	0	0	0	0	1	0	1	1	0	0	0	0	0	1	1

Table 103: Configuring the camera: registers

## Sample program

The following sample code in C/C++ shows how the register is set for video mode/format, trigger mode etc. using the FireGrab and FireStack API.

### Example FireGrab

```

...
// Set Videoformat
if(Result==FCE_NOERROR)
    Result= Camera.SetParameter(FGP_IMAGEFORMAT,MAKEIMAGEFORMAT(RES_640_480,
CM_Y8, FR_15));

// Set external Trigger
if(Result==FCE_NOERROR)
    Result= Camera.SetParameter(FGP_TRIGGER,MAKETRIGGER(1,0,0,0,0));

// Start DMA logic
if(Result==FCE_NOERROR)
    Result=Camera.OpenCapture();

// Start Sensor
if(Result==FCE_NOERROR)
    Result=Camera.StartDevice();
...
    
```

### Example FireStack API

```

...
// Set framerate

Result=WriteQuad(HIGHOFFSET,m_Props.CmdRegBase+CCR_FRAMERATE, (UINT32)m_Parms.Framerate<<29);

// Set mode
if(Result)

Result=WriteQuad(HIGHOFFSET,m_Props.CmdRegBase+CCR_VMODE, (UINT32)m_Parms.VideoMode<<29);

// Set format
if(Result)

Result=WriteQuad(HIGHOFFSET,m_Props.CmdRegBase+CCR_VFORMAT, (UINT32)m_Parms.VideoFormat<<29);

// Set trigger
if(Result)
{
Mode=0;
if(m_Parms.TriggerMode==TM_EXTERN)
Mode=0x82000000;
if(m_Parms.TriggerMode==TM_MODE15)
Mode=0x820F0000;
WriteQuad(HIGHOFFSET,m_Props.CmdRegBase+CCR_TRGMODE, Mode);
}

// Start continuous ISO if not oneshot triggermode
if(Result && m_Parms.TriggerMode!=TM_ONESHOT)
Result=WriteQuad(HIGHOFFSET,m_Props.CmdRegBase+CCR_ISOENABLE, 0x80000000);

...

```

## Configuration ROM

The information in the configuration ROM is needed to identify the node, its capabilities and which drivers are required.

The base address for the configuration ROM for all registers is FFFF F0000000h.

#### Note



If you want to use the DirectControl program to read or write to a register, enter the following value in the address field:

F0F00000h + Offset

The configuration ROM is divided into

- Bus info block: providing critical information about the bus-related capabilities
- Root directory: specifying the rest of the content and organization, such as:
  - Node unique ID leaf
  - Unit directory
  - Unit dependent information

The base address of the camera control register is calculated as follows based on the camera-specific base address:

	Offset	0 to 7	8 to 15	16 to 23	24 to 31	
Bus info block	400h	04	29	0C	C0	
	404h	31	33	39	34	.... ASCII for 1394
	408h	20	00	B2	03	.... Bus capabilities
	40Ch	00	0A	47	01	.... <i>Node_Vendor_Id</i> , <i>Chip_id_hi</i>
	410h	Serial number				.... <i>Chip_id_lo</i>
Root directory	414h	00	04	B7	85	According to IEEE1212, the root directory may have another length. The keys (e.g. 8D) point to the offset factors rather than the offset (e.g. 420h) itself.
	418h	03	00	0A	47	
	41Ch	0C	00	83	C0	
	420h	8D	00	00	02	
	424h	D1	00	00	04	

Table 104: Configuration ROM

The entry with key 8D in the root directory (420h in this case) provides the offset for the node unique ID leaf.

To compute the effective start address of the node unique ID leaf:

To compute the effective start address of the node unique ID leaf	
currAddr	= node unique ID leaf address
destAddr	= address of directory entry
addrOffset	= value of directory entry
destAddr	= currAddr + (4 × addrOffset)
	= 420h + (4 × 000002h)
	= 428h

Table 105: Computing effective start address

$$420h + 000002h \times 4 = 428h$$

	Offset	0 to 7	8 to 15	16 to 23	24 to 31	
Node unique ID leaf	428h	00	02	5E	9E	to.CRC
	42Ch	00	0A	47	01	....Node_Vendor_Id,Chip_id_hi
	430h	00	00	Serial number		

Table 106: Configuration ROM

The entry with key D1 in the root directory (424h in this case) provides the offset for the unit directory as follows:

$$424h + 000004 \times 4 = 434h$$

	Offset	0 to 7	8 to 15	16 to 23	24 to 31
Unit directory	434h	00	03	93	7D
	438h	12	00	A0	2D
	43Ch	13	00	01	02
	440h	D4	00	00	01

Table 107: Configuration ROM

The entry with key D4 in the unit directory (440h in this case) provides the offset for unit dependent info:

$$440h + 0000xx * 4 = 444h$$

	Offset	0 to 7	8 to 15	16 to 23	24 to 31	
Unit dependent info	444h	00	0B	A9	6E	to.unit_dep_info_length, CRC
	448h	40	3C	00	00	to.command_regs_base
	44Ch	81	00	00	02	to.vendor_name_leaf
	450h	82	00	00	06	to.model_name_leaf
	454h	38	00	00	10	to.unit_sub_sw_version
	458h	39	00	00	00	to.Reserved
	45Ch	3A	00	00	00	to.Reserved
	460h	3B	00	00	00	to.Reserved
	464h	3C	00	01	00	to.vendor_unique_info_0
	468h	3D	00	92	00	to.vendor_unique_info_1
	46Ch	3E	00	00	65	to.vendor_unique_info_2
	470h	3F	00	00	00	to.vendor_unique_info_3

Table 108: Configuration ROM



And finally, the entry with key 40 (448h in this case) provides the offset for the camera control register:

$$\text{FFFF F0000000h} + 3\text{C0000h} \times 4 = \text{FFFF F0F00000h}$$

The base address of the camera control register is thus:

FFFF F0F00000h

The offset entered in the table always refers to the base address of F0F00000h.

## Implemented registers (IIDC V1.31)

The following tables show how standard registers from IIDC V1.31 are implemented in the camera:

- Base address is F0F00000h
- Differences and explanations can be found in the Description column.

### Camera initialize register

Offset	Name	Description
000h	INITIALIZE	Assert MSB = 1 for Init.

*Table 109: Camera initialize register*

### Inquiry register for video format

Offset	Name	Field	Bit	Description
100h	V_FORMAT_INQ	Format_0	[0]	Up to VGA (non compressed)
		Format_1	[1]	SVGA to XGA
		Format_2	[2]	SXGA to UXGA
		Format_3	[3 to 5]	Reserved
		Format_6	[6]	Still Image Format
		Format_7	[7]	Partial Image Format
		---	[8 to 31]	Reserved

*Table 110: Format inquiry register*

## Inquiry register for video mode

Offset	Name	Field	Bit	Description	Color mode
180h	V_MODE_INQ (Format_0)	Mode_0	[0]	160 × 120	YUV 4:4:4
		Mode_1	[1]	320 × 240	YUV 4:2:2
		Mode_2	[2]	640 × 480	YUV 4:1:1
		Mode_3	[3]	640 × 480	YUV 4:2:2
		Mode_4	[4]	640 × 480	RGB
		Mode_5	[5]	640 × 480	Mono8
		Mode_6	[6]	640 × 480	Mono16
		Mode_X	[7]	Reserved	
		---	[8 to 31]	Reserved (zero)	
184h	V_MODE_INQ (Format_1)	Mode_0	[0]	800 × 600	YUV 4:2:2
		Mode_1	[1]	800 × 600	RGB
		Mode_2	[2]	800 × 600	Mono8
		Mode_3	[3]	1024 × 768	YUV 4:2:2
		Mode_4	[4]	1024 × 768	RGB
		Mode_5	[5]	1024 × 768	Mono8
		Mode_6	[6]	800 × 600	Mono16
		Mode_7	[7]	1024 × 768	Mono16
		---	[8 to 31]	Reserved (zero)	
188h	V_MODE_INQ (Format_2)	Mode_0	[0]	1280 × 960	YUV 4:2:2
		Mode_1	[1]	1280 × 960	RGB
		Mode_2	[2]	1280 × 960	Mono8
		Mode_3	[3]	1600 × 1200	YUV 4:2:2
		Mode_4	[4]	1600 × 1200	RGB
		Mode_5	[5]	1600 × 1200	Mono8
		Mode_6	[6]	1280 × 960	Mono16
		Mode_7	[7]	1600 × 1200	Mono16
		---	[8 to 31]	Reserved (zero)	
18Ch...197h	Reserved for other V_MODE_INQ_x for Format_x.			Always 0	
198h	V_MODE_INQ_6 (Format_6)			Always 0	

Table 111: Video mode inquiry register

Offset	Name	Field	Bit	Description	Color mode
19Ch	V_MODE_INQ (Format_7)	Mode_0	[0]	Format_7 Mode_0	
		Mode_1	[1]	Format_7 Mode_1	
		Mode_2	[2]	Format_7 Mode_2	
		Mode_3	[3]	Format_7 Mode_3	
		Mode_4	[4]	Format_7 Mode_4	
		Mode_5	[5]	Format_7 Mode_5	
		Mode_6	[6]	Format_7 Mode_6	
		Mode_7	[7]	Format_7 Mode_7	
		---	[8 to 31]	Reserved (zero)	

Table 111: Video mode inquiry register (continued)

### Inquiry register for video frame rate and base address

Offset	Name	Field	Bit	Description
200h	V_RATE_INQ (Format_0, Mode_0)	FrameRate_0	[0]	Reserved
		FrameRate_1	[1]	Reserved
		FrameRate_2	[2]	7.5 fps
		FrameRate_3	[3]	15 fps
		FrameRate_4	[4]	30 fps
		FrameRate_5	[5]	60 fps
		FrameRate_6	[6]	120 fps (V1.31)
		FrameRate_7	[7]	240 fps (V1.31)
		---	[8 to 31]	Reserved (zero)
204h	V_RATE_INQ (Format_0, Mode_1)	FrameRate_0	[0]	1.875 fps
		FrameRate_1	[1]	3.75 fps
		FrameRate_2	[2]	7.5 fps
		FrameRate_3	[3]	15 fps
		FrameRate_4	[4]	30 fps
		FrameRate_5	[5]	60 fps
		FrameRate_6	[6]	120 fps (V1.31)
		FrameRate_7	[7]	240 fps (V1.31)
		---	[8 to 31]	Reserved (zero)

Table 112: Frame rate inquiry register

Offset	Name	Field	Bit	Description
208h	V_RATE_INQ (Format_0, Mode_2)	FrameRate_0	[0]	1.875 fps
		FrameRate_1	[1]	3.75 fps
		FrameRate_2	[2]	7.5 fps
		FrameRate_3	[3]	15 fps
		FrameRate_4	[4]	30 fps
		FrameRate_5	[5]	60 fps
		FrameRate_6	[6]	120 fps (V1.31)
		FrameRate_7	[7]	240 fps (V1.31)
		---	[8 to 31]	Reserved (zero)
20Ch	V_RATE_INQ (Format_0, Mode_3)	FrameRate_0	[0]	1.875 fps
		FrameRate_1	[1]	3.75 fps
		FrameRate_2	[2]	7.5 fps
		FrameRate_3	[3]	15 fps
		FrameRate_4	[4]	30 fps
		FrameRate_5	[5]	60 fps
		FrameRate_6	[6]	120 fps (V1.31)
		FrameRate_7	[7]	240 fps (V1.31)
		---	[8 to 31]	Reserved (zero)
210h	V_RATE_INQ (Format_0, Mode_4)	FrameRate_0	[0]	1.875 fps
		FrameRate_1	[1]	3.75 fps
		FrameRate_2	[2]	7.5 fps
		FrameRate_3	[3]	15 fps
		FrameRate_4	[4]	30 fps
		FrameRate_5	[5]	60 fps
		FrameRate_6	[6]	120 fps (V1.31)
		FrameRate_7	[7]	240 fps (V1.31)
		---	[8 to 31]	Reserved (zero)

Table 112: Frame rate inquiry register (continued)

Offset	Name	Field	Bit	Description
214h	V_RATE_INQ (Format_0, Mode_5)	FrameRate_0	[0]	1.875 fps
		FrameRate_1	[1]	3.75 fps
		FrameRate_2	[2]	7.5 fps
		FrameRate_3	[3]	15 fps
		FrameRate_4	[4]	30 fps
		FrameRate_5	[5]	60 fps
		FrameRate_6	[6]	120 fps (V1.31)
		FrameRate_7	[7]	240 fps (V1.31)
		---	[8 to 31]	Reserved (zero)
218h	V_RATE_INQ	(Format_0, Mode_6)	[0]	1.875 fps
		FrameRate_0		
		FrameRate_1	[1]	3.75 fps
		FrameRate_2	[2]	7.5 fps
		FrameRate_3	[3]	15 fps
		FrameRate_4	[4]	30 fps
		FrameRate_5	[5]	60 fps
		FrameRate_6	[6]	120 fps (V1.31)
		FrameRate_7	[7]	240 fps (V1.31)
---	[8 to 31]	Reserved (zero)		
21Ch...21Fh	Reserved V_RATE_INQ_0_x (for other Mode_x of Format_0)			Always 0
220h	V_RATE_INQ (Format_1, Mode_0)	FrameRate_0	[0]	Reserved
		FrameRate_1	[1]	3.75 fps
		FrameRate_2	[2]	7.5 fps
		FrameRate_3	[3]	15 fps
		FrameRate_4	[4]	30 fps
		FrameRate_5	[5]	60 fps
		FrameRate_6	[6]	120 fps (V1.31)
		FrameRate_7	[7]	240 fps (V1.31)
		---	[8 to 31]	Reserved (zero)

Table 112: Frame rate inquiry register (continued)

Offset	Name	Field	Bit	Description
224h	V_RATE_INQ (Format_1, Mode_1)	FrameRate_0	[0]	Reserved
		FrameRate_1	[1]	Reserved
		FrameRate_2	[2]	7.5 fps
		FrameRate_3	[3]	15 fps
		FrameRate_4	[4]	30 fps
		FrameRate_5	[5]	60 fps
		FrameRate_6	[6]	120 fps (V1.31)
		FrameRate_7	[7]	240 fps (V1.31)
		---	[8 to 31]	Reserved (zero)
228h	V_RATE_INQ (Format_1, Mode_2)	FrameRate_0	[0]	Reserved
		FrameRate_1	[1]	Reserved
		FrameRate_2	[2]	7.5 fps
		FrameRate_3	[3]	15 fps
		FrameRate_4	[4]	30 fps
		FrameRate_5	[5]	60 fps
		FrameRate_6	[6]	120 fps (V1.31)
		FrameRate_7	[7]	240 fps (V1.31)
		---	[8 to 31]	Reserved (zero)
22Ch	V_RATE_INQ(Format_1, Mode_3)	FrameRate_0	[0]	1.875 fps
		FrameRate_1	[1]	3.75 fps
		FrameRate_2	[2]	7.5 fps
		FrameRate_3	[3]	15 fps
		FrameRate_4	[4]	30 fps
		FrameRate_5	[5]	60 fps
		FrameRate_6	[6]	120 fps (V1.31)
		FrameRate_7	[7]	240 fps (V1.31)
		---	[8 to 31]	Reserved (zero)

Table 112: Frame rate inquiry register (continued)

Offset	Name	Field	Bit	Description
230h	V_RATE_INQ (Format_1, Mode_4)	FrameRate_0	[0]	1.875 fps
		FrameRate_1	[1]	3.75 fps
		FrameRate_2	[2]	7.5 fps
		FrameRate_3	[3]	15 fps
		FrameRate_4	[4]	30 fps
		FrameRate_5	[5]	60 fps
		FrameRate_6	[6]	120 fps (V1.31)
		FrameRate_7	[7]	240 fps (V1.31)
		---	[8 to 31]	Reserved (zero)
234h	V_RATE_INQ (Format_1, Mode_5)	FrameRate_0	[0]	1.875 fps
		FrameRate_1	[1]	3.75 fps
		FrameRate_2	[2]	7.5 fps
		FrameRate_3	[3]	15 fps
		FrameRate_4	[4]	30 fps
		FrameRate_5	[5]	60 fps
		FrameRate_6	[6]	120 fps (V1.31)
		FrameRate_7	[7]	240 fps (V1.31)
		---	[8 to 31]	Reserved (zero)
238h	V_RATE_INQ (Format_1, Mode_6)	FrameRate_0	[0]	1.875 fps
		FrameRate_1	[1]	3.75 fps
		FrameRate_2	[2]	7.5 fps
		FrameRate_3	[3]	15 fps
		FrameRate_4	[4]	30 fps
		FrameRate_5	[5]	60 fps
		FrameRate_6	[6]	120 fps (V1.31)
		FrameRate_7	[7]	240 fps (V1.31)
		---	[8 to 31]	Reserved (zero)

Table 112: Frame rate inquiry register (continued)

Offset	Name	Field	Bit	Description
23Ch	V_RATE_INQ (Format_1, Mode_7)	FrameRate_0	[0]	1.875 fps
		FrameRate_1	[1]	3.75 fps
		FrameRate_2	[2]	7.5 fps
		FrameRate_3	[3]	15 fps
		FrameRate_4	[4]	30 fps
		FrameRate_5	[5]	60 fps
		FrameRate_6	[6]	120 fps (V1.31)
		FrameRate_7	[7]	Reserved
		---	[8 to 31]	Reserved (zero)
240h	V_RATE_INQ (Format_2, Mode_0)	FrameRate_0	[0]	1.875 fps
		FrameRate_1	[1]	3.75 fps
		FrameRate_2	[2]	7.5 fps
		FrameRate_3	[3]	15 fps
		FrameRate_4	[4]	30 fps
		FrameRate_5	[5]	60 fps
		FrameRate_6	[6]	Reserved
		FrameRate_7	[7]	Reserved
		---	[8 to 31]	Reserved (zero)
244h	V_RATE_INQ (Format_2, Mode_1)	FrameRate_0	[0]	1.875 fps
		FrameRate_1	[1]	3.75 fps
		FrameRate_2	[2]	7.5 fps
		FrameRate_3	[3]	15 fps
		FrameRate_4	[4]	30 fps
		FrameRate_5	[5]	60 fps
		FrameRate_6	[6]	Reserved
		FrameRate_7	[7]	Reserved
		---	[8 to 31]	Reserved (zero)

Table 112: Frame rate inquiry register (continued)



Offset	Name	Field	Bit	Description
248h	V_RATE_INQ (Format_2, Mode_2)	FrameRate_0	[0]	1.875 fps
		FrameRate_1	[1]	3.75 fps
		FrameRate_2	[2]	7.5 fps
		FrameRate_3	[3]	15 fps
		FrameRate_4	[4]	30 fps
		FrameRate_5	[5]	60 fps
		FrameRate_6	[6]	120 fps (V1.31)
		FrameRate_7	[7]	Reserved
		---	[8 to 31]	Reserved (zero)
24Ch	V_RATE_INQ (Format_2, Mode_3)	FrameRate_0	[0]	1.875 fps
		FrameRate_1	[1]	3.75 fps
		FrameRate_2	[2]	7.5 fps
		FrameRate_3	[3]	15 fps
		FrameRate_4	[4]	30 fps
		FrameRate_5	[5]	60 fps
		FrameRate_6	[6]	Reserved
		FrameRate_7	[7]	Reserved
		---	[8 to 31]	Reserved (zero)
250h	V_RATE_INQ (Format_2, Mode_4)	FrameRate_0	[0]	1.875 fps
		FrameRate_1	[1]	3.75 fps
		FrameRate_2	[2]	7.5 fps
		FrameRate_3	[3]	15 fps
		FrameRate_4	[4]	30 fps
		FrameRate_5	[5]	Reserved
		FrameRate_6	[6]	Reserved
		FrameRate_7	[7]	Reserved
		---	[8 to 31]	Reserved (zero)

Table 112: Frame rate inquiry register (continued)

Offset	Name	Field	Bit	Description
254h	V_RATE_INQ (Format_2, Mode_5)	FrameRate_0	[0]	1.875 fps
		FrameRate_1	[1]	3.75 fps
		FrameRate_2	[2]	7.5 fps
		FrameRate_3	[3]	15 fps
		FrameRate_4	[4]	30 fps
		FrameRate_5	[5]	60 fps
		FrameRate_6	[6]	Reserved
		FrameRate_7	[7]	Reserved
		---	[8 to 31]	Reserved (zero)
258h	V_RATE_INQ (Format_2, Mode_6)	FrameRate_0	[0]	1.875 fps
		FrameRate_1	[1]	3.75 fps
		FrameRate_2	[2]	7.5 fps
		FrameRate_3	[3]	15 fps
		FrameRate_4	[4]	30 fps
		FrameRate_5	[5]	60 fps
		FrameRate_6	[6]	Reserved
		FrameRate_7	[7]	Reserved
		---	[8 to 31]	Reserved (zero)
25Ch	V_RATE_INQ (Format_2, Mode_7)	FrameRate_0	[0]	1.875 fps
		FrameRate_1	[1]	3.75 fps
		FrameRate_2	[2]	7.5 fps
		FrameRate_3	[3]	15 fps
		FrameRate_4	[4]	30 fps
		FrameRate_5	[5]	60 fps
		FrameRate_6	[6]	Reserved
		FrameRate_7	[7]	Reserved
		---	[8 to 31]	Reserved
260h...2BFh	Reserved V_RATE_INQ_y_x (for other Format_y, Mode_x)			
2C0h	V_REV_INQ_6_0 (Format_6, Mode0)			Always 0
2C4hto2DFh	Reserved V_REV_INQ_6_x (for other Mode_x of Format_6)			Always 0
2E0h	V-CSR_INQ_7_0		[0 to 31]	CSR_quadlet offset for Format_7 Mode_0
2E4h	V-CSR_INQ_7_1		[0 to 31]	CSR_quadlet offset for Format_7 Mode_1

Table 112: Frame rate inquiry register (continued)

Offset	Name	Field	Bit	Description
2E8h		V-CSR_INQ_7_2	[0 to 31]	CSR_quadlet offset for Format_7 Mode_2
2ECh		V-CSR_INQ_7_3	[0 to 31]	CSR_quadlet offset for Format_7 Mode_3
2F0h		V-CSR_INQ_7_4	[0 to 31]	CSR_quadlet offset for Format_7 Mode_4
2F4h		V-CSR_INQ_7_5	[0 to 31]	CSR_quadlet offset for Format_7 Mode_5
2F8h		V-CSR_INQ_7_6	[0 to 31]	CSR_quadlet offset for Format_7 Mode_6
2FCh		V-CSR_INQ_7_7	[0 to 31]	CSR_quadlet offset for Format_7 Mode_7

Table 112: Frame rate inquiry register (continued)

### Inquiry register for basic function

Offset	Name	Field	Bit	Description
400h	BASIC_FUNC_INQ	Advanced_Feature_Inq	[0]	Inquiry for advanced features (vendor unique features)
		Vmode_Error_Status_Inq	[1]	Inquiry for existence of Vmode_Error_Status register
		Feature_Control_Error_Status_Inq	[2]	Inquiry for existence of Feature_Control_Error_Status
		Opt_Func_CSR_Inq	[3]	Inquiry for Opt_Func_CSR
		---	[4 to 7]	Reserved
		1394b_mode_Capability	[8]	Inquiry for 1394b_mode_Capability
		---	[9 to 15]	Reserved
		Cam_Power_Cntl	[16]	Camera process power ON/OFF capability
		---	[17 to 18]	Reserved
		One_Shot_Inq	[19]	One-shot transmission capability
		Multi_Shot_Inq	[20]	Multi-shot transmission capability
		---	[21 to 27]	Reserved
		Memory_Channel	[28 to 31]	Maximum memory channel number (N) If 0000, no user memory available

Table 113: Basic function inquiry register

### Inquiry register for feature presence

Offset	Name	Field	Bit	Description
404h	FEATURE_HI_INQ	Brightness	[0]	Brightness control
		Auto_Exposure	[1]	Auto_Exposure control
		---	[2]	Reserved
		White_Balance	[3]	White balance control
		Hue	[4]	Hue control
		Saturation	[5]	Saturation control
		Gamma	[6]	Gamma control
		Shutter	[7]	Shutter control
		Gain	[8]	Gain control
		Iris	[9]	Iris control
		Focus	[10]	Focus control
		Temperature	[11]	Temperature control
		Trigger	[12]	Trigger control
		Trigger_Delay	[13]	Trigger_Delay control
		---	[14]	Reserved
		Frame_Rate	[15]	Frame_Rate control
---	[16 to 31]	Reserved		
408h	FEATURE_LO_INQ	Zoom	[0]	Zoom control
		Pan	[1]	Pan control
		Tilt	[2]	Tilt control
		Optical_Filter	[3]	Optical_Filter control
		---	[4 to 15]	Reserved
		Capture_Size	[16]	Capture_Size for Format_6
		Capture_Quality	[17]	Capture_Quality for Format_6
		---	[16 to 31]	Reserved
40Ch	OPT_FUNCTION_INQ	---	[0]	Reserved
		PIO	[1]	Parallel Input/Output control
		SIO	[2]	Serial Input/Output control
		Strobe_out	[4 to 31]	Strobe signal output

Table 114: Feature presence inquiry register

Offset	Name	Field	Bit	Description
410h .. 47Fh	Reserved			Address error on access
480h	Advanced_Feature_Inq	Advanced_Feature_Quadlet_Offset	[0 to 31]	<p>Quadlet offset of the advanced feature CSR's from the base address of initial register space (vendor unique)</p> <p>This register is the offset for the Access_Control_Register; thus, the base address for Advanced Features.</p> <p>Access_Control_Register does not prevent access to advanced features. In some programs it should still always be activated first.</p> <p>Advanced Feature Set Unique Value is 7ACh and CompanyID is A47h.</p>
484h	PIO_Control_CSR_Inq	PIO_Control_Quadlet_Offset	[0 to 31]	Quadlet offset of the PIO_Control CSR's from the base address of initial register space (vendor unique)
488h	SIO_Control_CSR_Inq	SIO_Control_Quadlet_Offset	[0 to 31]	Quadlet offset of the SIO_Control CSR's from the base address of initial register space (vendor unique)
48Ch	Strobe_Output_CSR_Inq	Strobe_Output_Quadlet_Offset	[0 to 31]	Quadlet offset of the Strobe_Output signal CSR's from the base address of initial register space (vendor unique)

Table 114: Feature presence inquiry register (continued)

### Inquiry register for feature elements

Register	Name	Field	Bit	Description
0xF0F00500	BRIGHTNESS_INQUIRY	Presence_Inq	[0]	Indicates presence of this feature (read only)
		Abs_Control_Inq	[1]	Capability of control with absolute value
		---	[2]	Reserved
		One_Push_Inq	[3]	One-push auto mode (controlled automatically by the camera once)
		Readout_Inq	[4]	Capability of reading out the value of this feature
		ON_OFF	[5]	Capability of switching this feature ON and OFF
		Auto_Inq	[6]	Auto Mode (controlled automatically by the camera)
		Manual_Inq	[7]	Manual Mode (controlled by user)
		Min_Value	[8 to 19]	Minimum value for this feature
		Max_Value	[20 to 31]	Maximum value for this feature
504h	AUTO_EXPOSURE_INQ	Same definition as Brightness_inq.		
508h	SHARPNESS_INQ	Same definition as Brightness_inq.		
50Ch	WHITE_BAL_INQ	Same definition as Brightness_inq.		
510h	HUE_INQ	Same definition as Brightness_inq.		
514h	SATURATION_INQ	Same definition as Brightness_inq.		
518h	GAMMA_INQ	Same definition as Brightness_inq.		
51Ch	SHUTTER_INQ	Same definition as Brightness_inq.		
520h	GAIN_INQ	Same definition as Brightness_inq.		
524h	IRIS_INQ	Always 0		
528h	FOCUS_INQ	Always 0		
52Ch	TEMPERATURE_INQ	Same definition as Brightness_inq.		

Table 115: Feature elements inquiry register

Register	Name	Field	Bit	Description
530h	TRIGGER_INQ	Presence_Inq	[0]	Indicates presence of this feature (read only)
		Abs_Control_Inq	[1]	Capability of control with absolute value
		---	[2 to 3]	Reserved
		Readout_Inq	[4]	Capability of reading out the value of this feature
		ON_OFF	[5]	Capability of switching this feature ON and OFF
		Polarity_Inq	[6]	Capability of changing the polarity of the trigger input
		Value_Read_Inq	[7]	Capability of reading raw trigger input  Here you can read if trigger is active. In case of external trigger, you can read a combined signal.
		Trigger_Source0_Inq	[8]	Presence of Trigger Source 0 ID=0  Indicates usage of standard inputs.
		---	[9 to 31]	Reserved

Table 115: Feature elements inquiry register (continued)



Register	Name	Field	Bit	Description
534h	TRIGGER_DELAY_INQUIRY	Presence_Inq	[0]	Indicates presence of this feature (read only)
		Abs_Control_Inq	[1]	Capability of control with absolute value
		---	[2]	Reserved
		One_Push_Inq	[3]	One Push auto mode controlled automatically by the camera once)
		Readout_Inq	[4]	Capability of reading out the value of this feature
		ON_OFF	[5]	Capability of switching this feature ON and OFF
		Auto_Inq	[6]	Auto Mode (controlled automatically by the camera)
		Manual_Inq	[7]	Manual Mode (controlled by user)
		Min_Value	[8 to 19]	Minimum value for this feature
		Max_Value	[20 to 31]	Maximum value for this feature
538 .. 57Ch	Reserved for other FEATURE_HI_INQ			
580h	ZOOM_INQ	Always 0		
584h	PAN_INQ	Always 0		
588h	TILT_INQ	Always 0		
58Ch	OPTICAL_FILTER_INQ	Always 0		
590 .. 5BCh	Reserved for other FEATURE_LO_INQ	Always 0		
5C0h	CAPTURE_SIZE_INQ	Always 0		
5C4h	CAPTURE_QUALITY_INQ	Always 0		
5C8h .. 5FCh	Reserved for other FEATURE_LO_INQ	Always 0		

Table 115: Feature elements inquiry register (continued)

### Status and control registers for camera

Register	Name	Field	Bit	Description
600h	CUR-V-Frm_RATE/ Revision	Bit [0 to 2] for the frame rate		
604h	CUR-V-MODE	Bit [0 to 2] for the current video mode		
608h	CUR-V-FORMAT	Bit [0 to 2] for the current video format		
60Ch	ISO-Channel	Bit [0 to 3] for channel, [6..7] for ISO speed		
610h	Camera_Power	Always 0		
614h	ISO_EN/ Continuous_Shot	Bit 0: 1 for start continuous shot; 0 for stop continuous shot		
618h	Memory_Save	Always 0		
61Ch	One_Shot, Multi_Shot, Count Number	See chapter <a href="#">One-shot</a> on page 151 See chapter <a href="#">Multi-shot</a> on page 155		
620h	Mem_Save_Ch	Always 0		
624	Cur_Mem_Ch	Always 0		
628h	Vmode_Error_Status	Error in combination of Format/Mode/ISO Speed: Bit(0): No error; Bit(0)=1: error		
62Ch	Software_Trigger	Software trigger Write: 0: Reset software trigger 1: Set software trigger (self-cleared, when using edge mode; must be set back to 0 manually, when using level mode) Read: 0: Ready (meaning: it's possible to set a software trigger) 1: Busy (meaning: no trigger possible)		

Table 116: Status and control registers for camera

### Inquiry register for absolute value CSR offset address

Offset	Name	Description
700h	ABS_CSR_HI_INQ_0	Always 0
704h	ABS_CSR_HI_INQ_1	Always 0
708h	ABS_CSR_HI_INQ_2	Always 0
70Ch	ABS_CSR_HI_INQ_3	Always 0

Table 117: Absolute value inquiry register

Offset	Name	Description
710h	ABS_CSR_HI_INQ_4	Always 0
714h	ABS_CSR_HI_INQ_5	Always 0
718h	ABS_CSR_HI_INQ_6	Always 0
71Ch	ABS_CSR_HI_INQ_7	Always 0
720h	ABS_CSR_HI_INQ_8	Always 0
724h	ABS_CSR_HI_INQ_9	Always 0
728h	ABS_CSR_HI_INQ_10	Always 0
72Ch	ABS_CSR_HI_INQ_11	Always 0
730h	ABS_CSR_HI_INQ_12	Always 0
734to77Fh	Reserved	Always 0
780h	ABS_CSR_LO_INQ_0	Always 0
784h	ABS_CSR_LO_INQ_1	Always 0
788h	ABS_CSR_LO_INQ_2	Always 0
78Ch	ABS_CSR_LO_INQ_3	Always 0
790hto7BFh	Reserved	Always 0
7C0h	ABS_CSR_LO_INQ_16	Always 0
7C4h	ABS_CSR_LO_INQ_17	Always 0
7C8hto7FFh	Reserved	Always 0

Table 117: Absolute value inquiry register (continued)

### Status and control register for one-push

The OnePush feature, WHITE\_BALANCE, is currently implemented. If this flag is set, the feature becomes immediately active, even if no images are being input (see chapter [One-push white balance](#) on page 101).

Offset	Name	Field	Bit	Description
800h	BRIGHTNESS	Presence_Inq	[0]	Presence of this feature 0: N/A 1: Available
		Abs_Control	[1]	Absolute value control 0: Control with value in the Value field 1: Control with value in the Absolute value CSR If this bit = 1, value in the Value field is ignored.
		---	[2 to 4]	Reserved
		One_Push	[5]	Write 1: begin to work (self-cleared after operation)  Read: Value=1 in operation Value=0 not in operation If A_M_Mode =1, this bit is ignored.
		ON_OFF	[6]	Write: ON or OFF this feature Read: read a status 0: OFF, 1: ON If this bit =0, other fields will be read only.
		A_M_Mode	[7]	Write: set the mode Read: read a current mode 0: Manual 1: Auto
		---	[8 to 19]	Reserved
		Value	[20 to 31]	Value. Write the value in auto mode, this field is ignored. If ReadOut capability is not available, read value has no meaning.
804h	AUTO-EXPOSURE			See above Note: Target gray level parameter in SmartView corresponds to Auto_exposure register 0xF0F00804 (IIDC).

Table 118: Feature control register

Offset	Name	Field	Bit	Description
80Ch	WHITE-BALANCE	Presence_Inq	[0]	Presence of this feature 0: N/A 1: Available Always 0 for Mono
		Abs_Control	[1]	Absolute value control 0: Control with value in the Value field 1: Control with value in the Absolute value CSR If this bit = 1, value in the Value field is ignored.
		---	[2 to 4]	Reserved
		One_Push	[5]	Write 1: begin to work (self-cleared after operation) Read: Value=1 in operation Value=0 not in operation If A_M_Mode =1, this bit is ignored.
		ON_OFF	[6]	Write: ON or OFF this feature, Read: read a status 0: OFF 1: ON If this bit =0, other fields will be read only.
		A_M_Mode	[7]	Write: set the mode Read: read a current mode 0: Manual 1: Auto
		U_Value / B_Value	[8 to19]	U value / B value Write the value in AUTO mode, this field is ignored. If ReadOut capability is not available, read value has no meaning.
		V_Value / R_Value	[20 to31]	V value / R value Write the value in AUTO mode, this field is ignored. If ReadOut capability is not available, read value has no meaning.
810h	HUE			See above Always 0 for Mono
814h	SATURATION			See above Always 0 for Mono
818h	GAMMA			See above

Table 118: Feature control register (continued)

Offset	Name	Field	Bit	Description
81Ch	SHUTTER			See Advanced Feature time base See <a href="#">table 45</a>
820h	GAIN			See above
824h	IRIS			Always 0
828h	FOCUS			Always 0
830h	TRIGGER_MODE			Can be effected via advanced feature IO_INP_CTRLx.
834h .. 87C	Reserved for other FEATURE_HI			Always 0
880h	Zoom			Always 0
884h	PAN			Always 0
888h	TILT			Always 0
88Ch	OPTICAL_FILTER			Always 0
890 .. 8BCh	Reserved for other FEATURE_LO			Always 0
8C0h	CAPTURE-SIZE			Always 0
8C4h	CAPTURE-QUALITY			Always 0
8C8h .. 8FCh	Reserved for other FEATURE_LO			Always 0

Table 118: Feature control register (continued)

### Feature control error status register

Offset	Name	Description
640h	Feature_Control_Error_Status_HI	Always 0
644h	Feature_Control_Error_Status_LO	Always 0

Table 119: Feature control error register

### Video mode control and status registers for Format\_7

#### Quadlet offset Format\_7 Mode\_0

The quadlet offset to the base address for Format\_7 Mode\_0, which can be read out at F0F002E0h (according to [table 112:](#)) gives 003C2000h.

$4 \times 3C2000h = F08000h$  so that the base address for the latter ([table 120:](#)) equals  
 $F0000000h + F08000h = F0F08000h$ .

#### Quadlet offset Format\_7 Mode\_1

The quadlet offset to the base address for Format\_7 Mode\_1, which can be read out at F0F002E4h (according to [table 112:](#)) gives 003C2400h.

$4 \times 003C2400h = F09000h$  so that the base address for the latter ([table 120:](#)) equals  
 $F0000000h + F09000h = F0F09000h$ .

#### Format\_7 control and status register (CSR)

Offset	Name	Description
000h	MAX_IMAGE_SIZE_INQ	According to IIDC V1.31
004h	UNIT_SIZE_INQ	According to IIDC V1.31
008h	IMAGE_POSITION	According to IIDC V1.31
00Ch	IMAGE_SIZE	According to IIDC V1.31
010h	COLOR_CODING_ID	See note
014h	COLOR_CODING_INQ	According to IIDC V1.31
024h . . 033h	COLOR_CODING_INQ	Vendor Unique Color_Coding 0-127 (ID=128-255)  ID=132ECCID_MONO12 ID=136ECCID_RAW12  ID=133Reserved ID=134Reserved ID=135Reserved  See chapter <a href="#">Packed 12-Bit Mode</a> on page 130.
034h	PIXEL_NUMER_INQ	According to IIDC V1.31
038h	TOTAL_BYTES_HI_INQ	According to IIDC V1.31
03Ch	TOTAL_BYTES_LO_INQ	According to IIDC V1.31
040h	PACKET_PARA_INQ	See note
044h	BYTE_PER_PACKET	According to IIDC V1.31

Table 120: : Format\_7 control and status register

**Note**

- For all modes in Format\_7, ErrorFlag\_1 and ErrorFlag\_2 are refreshed on each access to the Format\_7 register.
- Contrary to IIDC V1.31, registers relevant to Format\_7 are refreshed on each access. The Setting\_1 bit is automatically cleared after each access.
- When ErrorFlag\_1 or ErrorFlag\_2 are set and Format\_7 is configured, no image capture is started.
- Contrary to IIDC V1.31, COLOR\_CODING\_ID is set to a default value after an INITIALIZE or reset.
- Contrary to IIDC V1.31, the UnitBytePerPacket field is already filled in with a fixed value in the PACKET\_PARA\_INQ register.

## Advanced features (Allied Vision-specific)

The camera has a variety of extended features going beyond the possibilities described in IIDC V1.31. The following chapter summarizes all available (Allied Vision-specific) advanced features in ascending register order.

**Note**

This chapter is a reference guide for advanced registers and does not explain the advanced features itself.

For detailed description of the theoretical background see

- Chapter [Description of the data path](#) on page 98
- Links given in the table below

### Advanced registers summary

The following table gives an overview of all available advanced registers:

Register	Register name	Description
0xF1000010	VERSION_INFO1	See <a href="#">Table 122: Advanced register: Extended version information</a> on page 227
0xF1000014	VERSION_INFO1_EX	
0xF1000018	VERSION_INFO3	
0xF100001C	VERSION_INFO3_EX	
0xF1000040	ADV_INQ_1	See <a href="#">Table 124: Advanced register: Advanced feature inquiry</a> on page 229
0xF1000044	ADV_INQ_2	
0xF1000048	ADV_INQ_3	In ADV_INQ_3 there is a new field F7MODE_MAPPING [3] Low-noise binning [9]
0xF100004C	ADV_INQ_4	

Table 121: Advanced registers summary



Register	Register name	Description
0xF1000100	CAMERA_STATUS	See <a href="#">Table 125: Advanced register: Camera status</a> on page 231
0xF1000200	MAX_RESOLUTION	See <a href="#">Table 126: Advanced register: Maximum resolution inquiry</a> on page 232
0xF1000208	TIMEBASE	See <a href="#">Table 127: Advanced register: Time base</a> on page 232
0xF100020C	EXTD_SHUTTER	See <a href="#">Table 129: : Advanced register: Extended shutter</a> on page 233
0xF1000210	TEST_IMAGE	See <a href="#">Table 130: Advanced register: Test images</a> on page 235
0xF1000240	LUT_CTRL	See <a href="#">Table 131: Advanced register: LUT</a> on page 236
0xF1000244	LUT_MEM_CTRL	
0xF1000248	LUT_INFO	
0xF1000298	DEFECT_PIXEL_CORRECTION	Defect pixel correction (only Guppy PRO F-503 CMOS)  See <a href="#">Table 132: Advanced register: Defect pixel correction</a> on page 238
0xF100029C		
0xF10002A0		
0xF1000300	IO_INP_CTRL1	Guppy PRO housing See <a href="#">Table 23: Advanced register: Input control</a> on page 85
0xF1000320	IO_OUTP_CTRL1	Guppy PRO housing See <a href="#">Table 29: Advanced register: Output control</a> on page 89
0xF1000324	IO_OUTP_CTRL2	
0xF1000328	IO_OUTP_CTRL3	
0xF1000340	IO_INTENA_DELAY	See <a href="#">Table 133: Advanced register: Delayed Integration Enable (IntEna)</a> on page 240
0xF1000360	AUTOSHUTTER_CTRL	See <a href="#">Table 134: Advanced register: Auto shutter control</a> on page 240
0xF1000364	AUTOSHUTTER_LO	
0xF1000368	AUTOSHUTTER_HI	
0xF1000370	AUTOGAIN_CTRL	See <a href="#">Table 135: Advanced register: Auto gain control</a> on page 242
0xF1000390	AUTOFNC_AOI	See <a href="#">Table 136: Advanced register: Autofunction AOI</a> on page 242
0xF1000394	AF_AREA_POSITION	
0xF1000398	AF_AREA_SIZE	
0xF10003A0	COLOR_CORR	Guppy PRO color cameras only  See <a href="#">Table 137: Advanced register: Color correction</a> on page 243

Table 121: Advanced registers summary (continued)

Register	Register name	Description
0xF1000400	TRIGGER_DELAY	See <a href="#">Table 138: Advanced register: Trigger delay</a> on page 244
0xF1000410	MIRROR_IMAGE	See <a href="#">Table 139: Advanced register: Mirror</a> on page 245
0xF1000510	SOFT_RESET	See <a href="#">Table 140: Advanced register: Soft reset</a> on page 245
0xF1000550	USER_PROFILES	See <a href="#">Table 146: Advanced register: User profiles</a> on page 251
0xF1000580	F7MODE_MAPPING	See <a href="#">Table 143: Advanced register: Format_7 mode mapping</a> on page 248
0xF1000640	SWFEATURE_CTRL	See <a href="#">Table 145: Advanced register: Software feature control (disable LEDs)</a> on page 250
0xF1000800 0xF1000804	IO_OUTP_PWM1	Guppy PRO housing See <a href="#">Table 31: PWM configuration registers</a> on page 91
0xF1000808 0xF100080C	IO_OUTP_PWM2	
0xF1000810 0xF1000814	IO_OUTP_PWM3	
0xF1000840	IO_INP_DEBOUNCE_1	See <a href="#">Table 63: Advanced register: Debounce time for input ports</a> on page 148
0xF1000850	IO_INP_DEBOUNCE_2	
0xF1000860	IO_INP_DEBOUNCE_3	
0xF1000870	IO_INP_DEBOUNCE_4	
0xF1000FFC	GPDATA_INFO	See <a href="#">Table 150: Advanced register: GPData buffer</a> on page 254
0xF1001000 to 0xF100nnnn	GPDATA_BUFFER	

Table 121: Advanced registers summary (continued)

**Note**

Advanced features should always be activated before accessing them.



**Note**

- Currently all registers can be written without being activated. This makes it easier to operate the camera using Directcontrol.
- Allied Vision reserves the right to require activation in future versions of the software.

### Extended version information register

The presence of each of the following features can be queried by the 0 bit of the corresponding register.

Register	Name	Field	Bit	Description
0xF1000010	VERSION_INFO1	µC type ID	[0 to 15]	Always 0
		µC version	[16 to 31]	Bcd-coded version number
0xF1000014	VERSION_INFO1_EX	µC version	[0 to 31]	Bcd-coded version number
0xF1000018	VERSION_INFO3	Camera type ID	[0 to 15]	See <a href="#">Table 123: Camera type ID list</a> on page 228.
		FPGA version	[16 to 31]	Bcd-coded version number
0xF100001C	VERSION_INFO3_EX	FPGA version	[0 to 31]	Bcd-coded version number
0xF1000020		---	[0 to 31]	Reserved
0xF1000024		---	[0 to 31]	Reserved
0xF1000028		---	[0 to 31]	Reserved
0xF100002C		---	[0 to 31]	Reserved
0xF1000030		OrderIDHigh	[0 to 31]	8 Byte ASCII Order ID
0xF1000034		OrderIDLow	[0 to 31]	

Table 122: Advanced register: Extended version information

The µC version and FPGA firmware version numbers are bcd-coded, which means that e.g. firmware version 0.85 is read as 0x0085 and version 1.10 is read as 0x0110.

The newly added VERSION\_INFOx\_EX registers contain extended bcd-coded version information formatted as *special.major.minor.patch*.

So reading the value 0x00223344 is decoded as:

- special: 0 (decimal)
- major: 22 (decimal)
- minor: 33 (decimal)
- patch: 44 (decimal)

This is decoded to the human readable version 22.33.44 (leading zeros are omitted).

**Note** If a camera returns the register set to all zero, that particular camera does not support the extended version information.



The FPGA type ID (= camera type ID) identifies the camera type with the help of the following list:

ID	Camera type
501	Guppy PRO F-031B
502	Guppy PRO F-031C
503	Guppy PRO F-032B
504	Guppy PRO F-032C
---	---
---	---
511	Guppy PRO F-125B
512	Guppy PRO F-125C
---	---
---	---
515	Guppy PRO F-146B
516	Guppy PRO F-146C
517	Guppy PRO F-201B
518	Guppy PRO F-201C
519	Guppy PRO F-503B
520	Guppy PRO F-503C
---	---
---	---

*Table 123: Camera type ID list*

## Advanced feature inquiry

This register indicates with a named bit if a feature is present or not. If a feature is marked as not present the associated register space might not be available and read/write errors may occur.

**Note** Ignore unnamed bits in the following table: these bits might be set or not.



Register	Name	Field	Bit	Description
0xF1000040	ADV_INQ_1	MaxResolution	[0]	
		TimeBase	[1]	
		ExtdShutter	[2]	
		TestImage	[3]	
		---	[4]	Reserved
		Sequences	[5]	
		VersionInfo	[6]	
		---	[7]	Reserved
		Look-up tables	[8]	
		---	[9]	Reserved
		---	[10]	Reserved
		---	[11]	Reserved
		---	[12]	Reserved
		---	[13]	Reserved
		TriggerDelay	[14]	
		Mirror image	[15]	
		Soft Reset	[16]	
		---	[17]	Reserved
		---	[18]	Reserved
		---	[19 to20]	Reserved
		User Sets	[21]	
		---	[22 to 29]	Reserved
Paramlist_Info	[30]			
GP_Buffer	[31]			

Table 124: Advanced register: Advanced feature inquiry

Register	Name	Field	Bit	Description
0xF1000044	ADV_INQ_2	Input_1	[0]	
		---	[1]	Reserved
		---	[2 to 7]	Reserved
		Output_1	[8]	
		Output_2	[9]	
		Output_3	[10]	
		---	[11]	Reserved
		---	[12 to 15]	Reserved
		IntEnaDelay	[16]	
		---	[17 to 23]	Reserved
		Output 1 PWM	[24]	Guppy PRO housing
		Output 2 PWM	[25]	
		Output 3 PWM	[26]	
		---	[27 to 31]	Reserved
0xF1000048	ADV_INQ_3	Camera Status	[0]	
		Max IsoSize	[1]	
		Paramupd_Timing	[2]	
		F7 mode mapping	[3]	
		Auto Shutter	[4]	
		Auto Gain	[5]	
		Auto FNC AOI	[6]	
		---	[7 to 11]	Reserved
		Defect Pixel Correction	[12]	
		---	[13 to 31]	Reserved
		0xF100004C	ADV_INQ_4	---
---	[1]			
---	[2]			
---	[18 to 31]			Reserved

Table 124: Advanced register: Advanced feature inquiry (continued)

### Camera status

This register allows to determine the current status of the camera. The most important flag is the Idle flag.

If the Idle flag is set the camera does not capture and does not send any images.

The ExSyncArmed flag indicates that the camera is set up for external triggering. Even if the camera is waiting for an external trigger event the Idle flag might get set.

Other bits in this register might be set or toggled: just ignore these bits.

**Note**

- Excessive polling of this register may slow down the operation of the camera. Therefore, the time between two polls of the status register should not be less than 5 ms. If the time between two read accesses is less than 5 ms the response will be delayed.
- Depending on shutter and isochronous settings the status flags might be set for a very short time; thus, will not be recognized by your application.

Register	Name	Field	Bit	Description
0xF1000100	CAMERA_STATUS	Presence_Inq	[0]	Indicates presence of this feature (read only)
		---	[1 to 23]	Reserved
		ID	[24 to 31]	Implementation ID = 0x01
0xF1000104		---	[0 to 14]	Reserved
		ExSyncArmed	[15]	External trigger enabled
		---	[16 to 27]	Reserved
		ISO	[28]	Isochronous transmission
		---	[29 to 30]	Reserved
		Idle	[31]	Camera idle

Table 125: Advanced register: Camera status

## Maximum resolution

This register indicates the highest resolution for the sensor and is read only.

**Note**

This register normally outputs the MAX\_IMAGE\_SIZE\_INQ Format\_7 Mode\_0 value.

This is the value given in the specifications tables under Picture size (max.) in chapter [Specifications](#) on page 52.

Register	Name	Field	Bit	Description
0xF1000200	MAX_RESOLUTION	MaxWidth	[0 to 15]	Sensor width (read only)
		MaxHeight	[16 to 31]	Sensor height (read only)

Table 126: Advanced register: Maximum resolution inquiry

## Time base

Corresponding to IIDC, exposure time is set via a 12-bit value in the corresponding register (SHUTTER\_INQ [51Ch] and SHUTTER [81Ch]).

This means that you can enter a value in the range of 1 to 4095.

Guppy PRO cameras use a time base which is multiplied by the shutter register value. This multiplier is configured as the time base via the TIMEBASE register.

Register	Name	Field	Bit	Description
0xF1000208	TIMEBASE	Presence_Inq	[0]	Indicates presence of this feature (read only)
		---	[1 to 7]	Reserved
		ExpOffset	[8 to 19]	Exposure offset in $\mu$ s
		---	[20 to 27]	Reserved
		Timebase_ID	[28 to 31]	See <a href="#">Table 128: : Time base ID</a> on page 233.

Table 127: Advanced register: Time base

The time base IDs 0-9 are in bit [28] to [31]. See [Table 128: : Time base ID](#) on page 233. Refer to the following table for code.

Default time base is 20  $\mu$ s: This means that the integration time can be changed in 20  $\mu$ s increments with the shutter control.

**Note** Time base can only be changed when the camera is in idle state and becomes active only after setting the shutter value.



The ExpOffset field specifies the camera specific exposure time offset in microseconds ( $\mu$ s). This time (which should be equivalent to [table 64:](#)) has to be added to the exposure time (set by any shutter register) to compute the real exposure time.

The ExpOffset field might be zero for some cameras: this has to be assumed as an unknown exposure time offset (according to former software versions).



ID	Time base in $\mu\text{s}$	
0	1	
1	2	
2	5	
3	10	
4	20	Default value
5	50	
6	100	
7	200	
8	500	
9	1000	

Table 128: : Time base ID

**Note** The ABSOLUTE VALUE CSR register, introduced in IIDC V1.3, is not implemented.



## Extended shutter

The exposure time for long-term integration of up to 67 seconds can be entered with  $\mu\text{s}$  precision via the EXTENDED\_SHUTTER register.

Register	Name	Field	Bit	Description
0xF100020C	EXTD_SHUTTER	Presence_Inq	[0]	Indicates presence of this feature (read only)
		---	[1 to 5]	Reserved
		ExpTime	[6 to 31]	Exposure time in $\mu\text{s}$

Table 129: : Advanced register: Extended shutter

The minimum allowed exposure time depends on the camera model. To determine this value write 1 to the ExpTime field and read back the minimum allowed exposure time.

The longest exposure time, 3FFFFFFh, corresponds to 67.11 seconds.

**Note**

- Exposure times entered via the 81Ch register are mirrored in the extended register, but not vice versa.
- Changes in this register have immediate effect, even when camera is transmitting.
- Extended shutter becomes inactive after writing to a format / mode / frame rate register.
- Extended shutter setting will be overwritten by the normal time base/shutter setting after Stop/Start of FireView or FireDemo.

### Test images

Bit [8] to [14] indicate which test images are saved. Setting bit [28] to [31] activates or deactivates existing test images.

By activating any test image the following auto features are automatically disabled:

- auto gain
- auto shutter
- auto white balance

Register	Name	Field	Bit	Description
0xF1000210	TEST_IMAGE	Presence_Inq	[0]	Indicates presence of this feature (read only)
		---	[1 to 7]	Reserved
		Image_Inq_1	[8]	Presence of test image 1 0: N/A 1: Available
		Image_Inq_2	[9]	Presence of test image 2 0: N/A 1: Available
		Image_Inq_3	[10]	Presence of test image 3 0: N/A 1: Available
		Image_Inq_4	[11]	Presence of test image 4 0: N/A 1: Available
		Image_Inq_5	[12]	Presence of test image 5 0: N/A 1: Available
		Image_Inq_6	[13]	Presence of test image 6 0: N/A 1: Available
		Image_Inq_7	[14]	Presence of test image 7 0: N/A 1: Available
		---	[15 to 27]	Reserved
		TestImage_ID	[28 to 31]	0: No test image active 1: Image 1 active 2: Image 2 active ...

Table 130: Advanced register: Test images

## Look-up tables (LUT)

Load the look-up tables to be used into the camera and choose the look-up table number via the LutNo field. Now you can activate the chosen LUT via the LUT\_CTRL register.

The LUT\_INFO register indicates how many LUTs the camera can store and shows the maximum size of the individual LUTs.

The possible values for LutNo are 0..n-1, whereas n can be determined by reading the field NumOfLuts of the LUT\_INFO register.

Register	Name	Field	Bit	Description
0xF1000240	LUT_CTRL	Presence_Inq	[0]	Indicates presence of this feature (read only)
		---	[1 to 5]	Reserved
		ON_OFF	[6]	Enable/disable this feature
		---	[7 to 25]	Reserved
		LutNo	[26 to 31]	Use look-up table with LutNo number
0xF1000244	LUT_MEM_CTRL	Presence_Inq	[0]	Indicates presence of this feature (read only)
		---	[1 to 4]	Reserved
		EnableMemWR	[5]	Enable write access
		---	[6 to 7]	Reserved
		AccessLutNo	[8 to 15]	
AddrOffset	[16 to 31]	byte		
0xF1000248	LUT_INFO	Presence_Inq	[0]	Indicates presence of this feature (read only)
		---	[1 to 2]	Reserved
		BitsPerValue	[3 to 7]	Bits used per table item
		NumOfLuts	[8 to 15]	Maximum number of look-up tables
		MaxLutSize	[16 to 31]	Maximum look-up table size (bytes)

Table 131: Advanced register: LUT

#### Note



The BitsPerValue field indicates how many bits are read from the LUT for any gray-value read from the sensor. To determine the number of bytes occupied for each gray-value round-up the BitsPerValue field to the next byte boundary.

Examples:

- BitsPerValue = 8 → 1 byte per gray-value
- BitsPerValue = 14 → 2 byte per gray-value

Divide MaxLutSize by the number of bytes per gray-value in order to get the number of LUT entries (gray levels): that is  $2^n$  with  $n$ =number of bits read from sensor.

**Note**

Guppy PRO cameras have the gamma feature implemented via a built-in look-up table. Therefore, you cannot use gamma and your own look-up table at the same time. Nevertheless, you may combine a gamma look-up table into your own look-up table.

**Note**

When using the LUT feature and the gamma feature pay attention to the following:

- gamma ON → look-up table is switched ON also
- gamma OFF → look-up table is switched OFF also
- look-up table OFF → gamma is switched OFF also
- look-up table ON → gamma is switched OFF

### Loading a look-up table into the camera

Loading a look-up table into the camera is done through the Gpdata\_BUFFER. Because the size of the Gpdata\_BUFFER is smaller than a complete look-up table the data must be written in multiple steps.

To load a look-up table into the camera:

1. Query the limits and ranges by reading LUT\_INFO and Gpdata\_INFO.
2. Set EnableMemWR to true (1).
3. Set AccessLutNo to the desired number.
4. Set AddrOffset to 0.
5. Write n look-up table data bytes to Gpdata\_BUFFER (n might be lower than the size of the Gpdata\_BUFFER; AddrOffset is automatically adjusted inside the camera).
6. Repeat step 5 until all data is written into the camera.
7. Set EnableMemWR to false (0).

### Defect pixel correction

**Definition** The defect pixel correction mode allows to correct an image with defect pixels. Via threshold you can define the defect pixels in an image. Defect pixel correction is done in the FPGA and defect pixel data can be stored inside the camera.

DPC = defect pixel correction

WR = write

RD = read

MEM, Mem = memory

**Note**

- Defect pixel correction is always done in Format\_7 Mode\_0.
- When using defect pixel correction with binning and sub-sampling: first switch to binning/sub-sampling modus and then apply defect pixel correction.

Register	Name	Field	Bit	Description
0xF1000298	DPC_CTRL	Presence_Inq	[0]	Indicates presence of this feature (read only)
		BuildError	[1]	Build defect pixel data that reports an error, e.g. more than 2000 defect pixels, see DPDataSize.
		---	[2 to 4]	Reserved
		BuildDPData	[5]	Build defect pixel data now
		ON_OFF	[6]	Enable/disable this feature
		Busy	[7]	Build defect pixel data in progress
		MemSave	[8]	Save defect pixel data to storage
		MemLoad	[9]	Load defect pixel data from storage
		ZeroDPData	[10]	Zero defect pixel data
		---	[11 to 17]	Reserved
		Mean	[18 to 24]	Calculated mean value (7 bit)
		Threshold	[25 to 31]	Threshold for defect pixel correction
0xF100029C	DPC_MEM	Presence_Inq	[0]	Indicates presence of this feature (read only)
		---	[1]	Reserved
		EnaMemWR	[2]	Enable write access from host to RAM
		EnaMemRD	[3]	Enable read access from RAM to host
		DPDataSize	[4 to 17]	Size of defect pixel data to read from RAM to host. A maximum of 2000 defect pixels can be stored. To get the number of defect pixels read out this value and divide by 4.  In case of more than 2000 defect pixels, DPDataSize is set to 2001 pixels (DPDataSize of 8004 divided by 4 equals 2001 pixels) and BuildError flag is set to 1.  Defect pixel correction data is done with first 2000 defect pixels only.
		AddrOffset	[18 to 31]	Address offset to selected defect pixel data

Table 132: Advanced register: Defect pixel correction

Register	Name	Field	Bit	Description
0xF10002A0	DPC_INFO	Presence_Inq	[0]	Indicates presence of this feature (read only)
		---	[1 to 3]	Reserved
		MinThreshold	[4 to 10]	Minimum value for threshold
		MaxThreshold	[11 to 17]	Maximum value for threshold
		MaxSize	[18 to 31]	Maximum size of defect pixel data

Table 132: Advanced register: Defect pixel correction (continued)

## Input/output pin control

### Note



- See chapter [Input/output pin control](#) on page 85
- See chapter [IO\\_INP\\_CTRL 1](#) on page 85
- See chapter [IO\\_OUTP\\_CTRL 1-3](#) on page 89
- See chapter [Output modes](#) on page 90

## Delayed Integration Enable (IntEna)

A delay time between initiating exposure on the sensor and the activation edge of the IntEna signal can be set using this register. The on/off flag activates/deactivates integration delay. The time can be set in  $\mu\text{s}$  in DelayTime.

### Note



- Only one edge is delayed.
- If IntEna\_Out is used to control an exposure, it is possible to have a variation in brightness or to precisely time a flash.

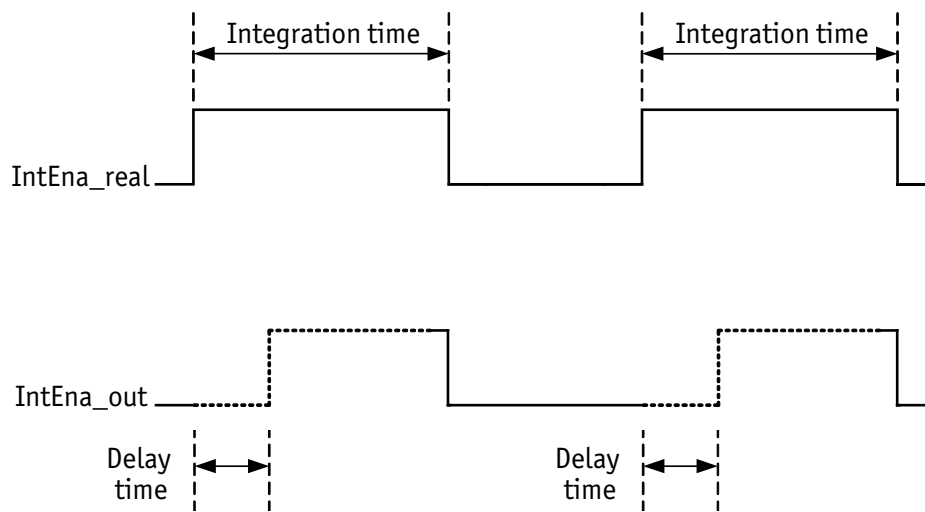

Figure 84: Delayed integration timing

Register	Name	Field	Bit	Description
0xF1000340	IO_INTENA_DELAY	Presence_Inq	[0]	Indicates presence of this feature (read only)
		---	[1 to 5]	Reserved
		ON_OFF	[6]	Enable/disable integration enable delay
		---	[7 to 11]	Reserved
		DELAY_TIME	[12 to 31]	Delay time in $\mu\text{s}$

Table 133: Advanced register: Delayed Integration Enable (IntEna)

## Auto shutter control

The table below illustrates the advanced register for auto shutter control. The purpose of this register is to limit the range within which auto shutter operates.

Register	Name	Field	Bit	Description
0xF1000360	AUTOSHUTTER_CTRL	Presence_Inq	[0]	Indicates presence of this feature (read only)
		---	[1 to 31]	Reserved
0xF1000364	AUTOSHUTTER_LO	---	[0 to 5]	Reserved
		MinValue	[6 to 31]	Minimum auto shutter value lowest possible value: 10 $\mu\text{s}$

Table 134: Advanced register: Auto shutter control



Register	Name	Field	Bit	Description
0xF1000368	AUTOSHUTTER_HI	---	[0 to 5]	Reserved
		MaxValue	[6 to 31]	Maximum auto shutter value

Table 134: Advanced register: Auto shutter control (continued)

**Note**



- Values can only be changed within the limits of shutter CSR.
- Changes in auto exposure register only have an effect when auto shutter is enabled.
- Auto exposure limits are: 50 to 205 (SmartView→Ctrl1 tab: Target gray level)

When both auto shutter and auto gain are enabled, priority is given to increasing shutter when brightness decreases. This is done to achieve the best image quality with lowest noise.

For increasing brightness, priority is given to lowering gain first for the same purpose.

MinValue and MaxValue limits the range the auto shutter feature is allowed to use for the regulation process. Both values are initialized with the minimum and maximum value defined in the standard SHUTTER\_INQ register (multiplied by the current active time base).

If you change the MinValue and/or MaxValue and the new range exceeds the range defined by the SHUTTER\_INQ register, the standard SHUTTER register will not show correct shutter values. In this case you should read the EXTENDED\_SHUTTER register for the current active shutter time.

Changing the auto shutter range might not affect the regulation, if the regulation is in a stable condition and no other condition affecting the image brightness is changed.

If both auto gain and auto shutter are enabled and if the shutter is at its upper boundary and gain regulation is in progress, increasing the upper auto shutter boundary has no effect on auto gain/shutter regulation as long as auto gain regulation is active.

**Note**



As with the Extended Shutter the value of MinValue and MaxValue must not be set to a lower value than the minimum shutter time.

## Auto gain control

The table below illustrates the advanced register for auto gain control.

Register	Name	Field	Bit	Description
0xF1000370	AUTOGAIN_CTRL	Presence_Inq	[0]	Indicates presence of this feature (read only)
		---	[1 to 3]	Reserved
		MaxValue	[4 to 15]	Maximum auto gain value
		---	[16 to 19]	Reserved
		MinValue	[20 to 31]	Minimum auto gain value

Table 135: Advanced register: Auto gain control

MinValue and MaxValue limits the range the auto gain feature is allowed to use for the regulation process. Both values are initialized with the minimum and maximum value defined in the standard GAIN\_INQ register.

Changing the auto gain range might not affect the regulation, if the regulation is in a stable condition and no other condition affecting the image brightness is changed.

If both auto gain and auto shutter are enabled and if the gain is at its lower boundary and shutter regulation is in progress, decreasing the lower auto gain boundary has no effect on auto gain/shutter regulation as long as auto shutter regulation is active.

Both values can only be changed within the range defined by the standard GAIN\_INQ register.

## Autofunction AOI

The table below illustrates the advanced register for autofunction AOI.

Register	Name	Field	Bit	Description
0xF1000390	AUTOFNC_AOI	Presence_Inq	[0]	Indicates presence of this feature (read only)
		---	[1 to 3]	Reserved
		ShowWorkArea	[4]	Show work area
		---	[5]	Reserved
		ON_OFF	[6]	Enable/disable AOI (see note above)
		---	[7]	Reserved
		YUNITS	[8 to 19]	Y units of work area/pos. beginning with 0 (read only)
XUNITS	[20 to 31]	X units of work area/pos. beginning with 0 (read only)		

Table 136: Advanced register: Autofunction AOI

Register	Name	Field	Bit	Description
0xF1000394	AF_AREA_POSITION	Left	[0 to 15]	Work area position (left coordinate)
		Top	[16 to 31]	Work area position (top coordinate)
0xF1000398	AF_AREA_SIZE	Width	[0 to 15]	Width of work area size
		Height	[16 to 31]	Height of work area size

Table 136: Advanced register: Autofunction AOI (continued)

The possible increment of the work area position and size is defined by the YUNITS and XUNITS fields. The camera automatically adjusts your settings to permitted values.

**Note**



If the adjustment fails and the work area size and/or work area position becomes invalid, then this feature is automatically switched off.

Read back the ON\_OFF flag, if this feature does not work as expected.

## Color correction

To switch off color correction in YUV mode: see bit [6]

Register	Name	Field	Bit	Description
0xF10003A0	COLOR_CORR	Presence_Inq	[0]	Indicates presence of this feature (read only)
		---	[1 to 5]	Reserved
		ON_OFF	[6]	Color correction on/off default: on Write: 02000000h to switch color correction OFF Write: 00000000h to switch color correction ON
		Reset	[7]	Reset to defaults
		---	[8 to 31]	Reserved

Table 137: Advanced register: Color correction

Register	Name	Field	Bit	Description
0xF10003A4	COLOR_CORR_COEFFIC11 = Crr		[0 to 31]	A number of 1000 equals a color correction coefficient of 1. Color correction values range -1000..+2000 and are signed 32 bit. In order for white balance to work properly ensure that the row sum equals to 1000. The maximum row sum is limited to 2000.
0xF10003A8	COLOR_CORR_COEFFIC12 = Cgr		[0 to 31]	
0xF10003AC	COLOR_CORR_COEFFIC13 = Cbr		[0 to 31]	
0xF10003B0	COLOR_CORR_COEFFIC21 = Crg		[0 to 31]	
0xF10003B4	COLOR_CORR_COEFFIC22 = Cgg		[0 to 31]	
0xF10003B8	COLOR_CORR_COEFFIC23 = Cbg		[0 to 31]	
0xF10003BC	COLOR_CORR_COEFFIC31 = Crb		[0 to 31]	
0xF10003C0	COLOR_CORR_COEFFIC32 = Cgb		[0 to 31]	
0xF10003C4	COLOR_CORR_COEFFIC33 = Cbb		[0 to 31]	
0xF10003A4 to 0xF10003FC				Reserved for testing purposes Do not touch!

Table 137: Advanced register: Color correction (continued)

For an explanation of the color correction matrix and for further information read chapter [Color correction](#) on page 132.

## Trigger delay

Register	Name	Field	Bit	Description
0xF1000400	TRIGGER_DELAY	Presence_Inq	[0]	Indicates presence of this feature (read only)
		---	[1 to 5]	Reserved
		ON_OFF	[6]	Trigger delay on/off
		---	[7 to 10]	Reserved
		DelayTime	[11 to 31]	Delay time in $\mu$ s

Table 138: Advanced register: Trigger delay

The advanced register allows start of the integration to be delayed via DelayTime by max.  $2^{21} \mu$ s, which is max. 2.1 s after a trigger edge was detected.

**Note** Trigger delay works with external trigger modes only.



## Mirror image

The table below illustrates the advanced register for Mirror image. Mirror image is only possible with Guppy PRO F-503.

- With Guppy PRO F-503B, horizontal and vertical mirror is possible.
- With Guppy PRO F-503C, only horizontal mirror is possible.

Register	Name	Field	Bit	Description
0xF1000410	MIRROR_IMAGE	Presence_Inq	[0]	Indicates presence of this feature (read only)
		---	[1 to 5]	Reserved
		ON_OFF	[6]	Mirror image on/off 1: on 0: off Default: off
		---	[7 to 31]	Reserved

Table 139: Advanced register: Mirror

## Soft reset

Register	Name	Field	Bit	Description
0xF1000510	SOFT_RESET	Presence_Inq	[0]	Indicates presence of this feature (read only)
		---	[1 to 5]	Reserved
		Reset	[6]	Initiate reset
		---	[7 to 19]	Reserved
		Delay	[20 to 31]	Delay reset in 10 ms steps

Table 140: Advanced register: Soft reset

The soft reset feature is similar to the INITIALIZE register, with the following differences:

- 1 or more bus resets will occur
- The FPGA will be rebooted

The reset can be delayed by setting the Delay to a value unequal to 0.

The delay is defined in 10 ms steps.

**Note** If the SOFT\_RESET has been issued, the camera no longer responds to further read/write requests.



You might detect errors of incomplete 1394 transactions.

## Maximum ISO packet size

Use this feature to increase the MaxBytePerPacket value of Format\_7 modes. This overwrites the maximum allowed isochronous packet size specified by IIDC V1.31.

Register	Name	Field	Bit	Description
0xF1000560	ISOSIZE_S400	Presence_Inq	[0]	Indicates presence of this feature (read only)
		---	[1 to 5]	Reserved
		ON_OFF	[6]	Enable/Disable S400 settings
		Set2Max	[7]	Set to maximum supported packet size
		---	[8 to 15]	Reserved
		MaxIsoSize	[16 to 31]	Maximum ISO packet size for S400
0xF1000564	ISOSIZE_S800	Presence_Inq	[0]	Indicates presence of this feature (read only)
		---	[1 to 5]	Reserved
		ON_OFF	[6]	Enable/Disable S800 settings
		Set2Max	[7]	Set to maximum supported packet size
		---	[8 to 15]	Reserved
		MaxIsoSize	[16 to 31]	Maximum ISO packet size for S800

Table 141: Advanced register: Maximum ISO packet size

**Example** For isochronous packets at a speed of S800 the maximum allowed packet size (IIDC V1.31) is 8192 byte. This feature allows you to extend the size of an isochronous packet up to 11.000 byte at S800. Thus, the isochronous bandwidth is increased from 64 MByte/s to approximately 84 MByte/s. You need either PCI Express or PCI-X (64 bit).

The Maximum ISO packet size feature to

- to reduces the asynchronous bandwidth available for controlling cameras by approximately 75%
- to may lead to slower responses on commands
- to is not covered by the IEEE 1394 specification
- to may not work with all available 1394 host adapters.

**Note** We strongly recommend to use PCI-X (64 bit) or PCI Express adapter.



**Restrictions** Note the restrictions in the following table. When using software with an Isochronous Resource Manager (IRM): deactivate it.

Software	Restrictions
FireGrab	Deactivate Isochronous Resource Manager: SetParameter (FGP_USEIRMFORBW, 0)
FireStack/FireClass	No restrictions
SDKs using Microsoft driver (Active FirePackage, Direct FirePackage, to)	n/a
Linux: libdc1394_1.x	No restrictions
Linux: libdc1394_2.x	Deactivate Isochronous Resource Manager: Set DC1394_CAPTURE_FLAGS_BANDWIDTH_ALLOC flag to 0
Third-party software	Deactivate Isochronous Resource Manager

Table 142: Restrictions for feature: Maximum ISO packet size

**Operation** The maximum allowed isochronous packet size can be set separately for the ISO speeds S400 and S800. Check the associated Presence\_Inq flag to see for which ISO speed this feature is available.

Setting the Set2Max flag to 1 sets the MaxIsoSize field to the maximum supported isochronous packet size. Use this flag to query the maximum supported size (may depend on the camera model).

Enable this feature by setting the ON\_OFF flag to 1 and the MaxIsoSize field to a value greater than the default packet size.

The camera ensures:

- that the value of the MaxIsoSize field is a multiple of 4.
- that the value isn't lower than the value specified by the IEEE1394 specification.

The settings are stored in the user sets.

**Note** Enabling this feature will not change the MaxBytePerPacket value automatically. The camera may not use the new isochronous packet size for the MaxBytePerPacket value until a write access to the desired Format\_7 mode has been issued.



## Format\_7 mode mapping (only Guppy PRO F-503)

With Format\_7 mode mapping it is possible to map special binning and sub-sampling modes to F7M1..F7M7. See [page 129](#). For default mappings see [table 53](#).

Register	Name	Field	Bit	Description
0xF1000580	F7MODE_MAPPING	Presence_Inq	[0]	Indicates presence of this feature (read only)
		---	[1 to 31]	Reserved
0xF1000584	F7MODE_MAP_INQ	F7MODE_00_INQ	[0]	Format_7 Mode_0 presence
		F7MODE_01_INQ	[1]	Format_7 Mode_1 presence
		to	to	to
		F7MODE_31_INQ	[31]	Format_7 Mode_31 presence
0xF1000588	Reserved	---	---	---
0xF100058C	Reserved	---	---	---
0xF1000590	F7MODE_0	Format_ID	[0 to 31]	Format ID (read only)
0xF1000594	F7MODE_1	Format_ID	[0 to 31]	Format ID for Format_7 Mode_1
0xF1000598	F7MODE_2	Format_ID	[0 to 31]	Format ID for Format_7 Mode_2
0xF100059C	F7MODE_3	Format_ID	[0 to 31]	Format ID for Format_7 Mode_3
0xF10005A0	F7MODE_4	Format_ID	[0 to 31]	Format ID for Format_7 Mode_4
0xF10005A4	F7MODE_5	Format_ID	[0 to 31]	Format ID for Format_7 Mode_5
0xF10005A8	F7MODE_6	Format_ID	[0 to 31]	Format ID for Format_7 Mode_6
0xF10005AC	F7MODE_7	Format_ID	[0 to 31]	Format ID for Format_7 Mode_7

Table 143: Advanced register: Format\_7 mode mapping

### Additional Format\_7 modes

With Format\_7 mode mapping you can add some special Format\_7 modes which aren't covered by the IIDC standard. These special modes implement binning and sub-sampling.

To stay as close as possible to the IIDC standard the Format\_7 modes can be mapped into the register space of the standard Format\_7 modes.

There are visible Format\_7 modes and internal Format\_7 modes:

- At any time only 8 Format\_7 modes can be accessed by a host computer.
- Visible Format\_7 modes are numbered from 0 to 7.
- Internal Format\_7 modes are numbered from 0 to 27.

Format\_7 Mode\_0 represents the mode with the maximum resolution of the camera: this visible mode cannot be mapped to any other internal mode.



The remaining visible Format\_7 Mode\_1 to Mode\_7 can be mapped to any internal Format\_7 mode.

### Example

To map the internal Format\_7 Mode\_19 to the visible Format\_7 Mode\_1, write the decimal number 19 to the above listed F7MODE\_1 register.

### Note

For available Format\_7 modes see [figure 58](#):



Setting the F7MODE\_x register to:

- -1 forces the camera to use the factory defined mode
- -2 disables the respective Format\_7 mode (no mapping is applied)

After setup of personal Format\_7 mode mappings you have to reset the camera. The mapping is performed during the camera startup only.

## Low-noise binning mode (2 × and 4 × binning) (Guppy PRO F-503 only)

This register enables/disables low-noise binning mode.

This means: an average (and not a sum) of the luminance values is calculated within the FPGA.

The image is, therefore, darker than with the usual binning mode, but the signal-to-noise ratio is better (approximately a factor of  $\sqrt{2}$ ).

Offset	Name	Field	Bit	Description
0xF10005B0	LOW_NOISE_BINNING	Presence_Inq	[0]	Indicates presence of this feature (read only)
		---	[1 to 5]	Reserved
		ON_OFF	[6]	Low-noise binning mode on/off
		---	[7 to 31]	Reserved

Table 144: Advanced register: Low-noise binning mode

## Software feature control (disable LED)

The software feature control register allows to enable/disable some features of the camera (e.g. disable LED). The settings are stored permanently within the camera and do not depend on any user set.

### Disable LEDs

- To disable LEDs set bit [17] to 1.
- To disable LEDs in SmartView:  
Adv3 tab, activate Disable LED functionality check box.

The camera does not show the status indicators during normal operation:

Examples:

- *Power on* is not shown.
- *Isochronous traffic* is not shown.
- *Asynchronous traffic* is not shown.

Register	Name	Field	Bit	Description
0xF1000640	SWFEATURE_CTRL	Presence_Inq	[0]	Indicates presence of this feature (read only)
		BlankLED_Inq	[1]	Indicates presence of <i>Disable LEDs</i> feature.
		---	[2 to 15]	Reserved
		---	[16]	Reserved
		BlankLED	[17]	0: Behavior as described in chapter <a href="#">Status LEDs</a> on page 82. 1: Disable LEDs. (Only error codes are shown.)
		---	[18 to 31]	Reserved

Table 145: Advanced register: Software feature control (disable LEDs)

#### Note



During the startup of the camera and if an error condition is present, the LEDs behave as described in Chapter Status LEDs on page 93ff.

## User profiles

**Definition** Within the IIDC specification user profiles are called memory channels. Often they are called user sets. In fact these are different expressions for the following: storing camera settings into a non-volatile memory inside the camera.

User profiles can be programmed with the following advanced feature register.

Offset	Name	Field	Bit	Description
0xF1000550	USER_PROFILE	Presence_Inq	[0]	Indicates presence of this feature (read only)
		Error	[1]	An error occurred
		---	[2 to 6]	Reserved
		Busy	[7]	Save/Load in progress
		Save	[8]	Save settings to profile
		Load	[9]	Load settings from profile
		SetDefaultID	[10]	Set Profile ID as default
		---	[11 to 19]	Reserved
		ErrorCode	[20 to 23]	Error code See <a href="#">Table 147: User profiles: Error codes</a> on page 252.
		---	[24 to 27]	Reserved
		ProfileID	[28 to 31]	ProfileID (memory channel)

Table 146: Advanced register: User profiles

In general, this advanced register is a wrapper around the standard memory channel registers with some extensions. In order to query the number of available user profiles please check the Memory\_Channel field of the BASIC\_FUNC\_INQ register at offset 0x400 (see IIDC V1.31 for details).

The ProfileID is equivalent to the memory channel number and specifies the profile number to store settings to or to restore settings from. In any case profile #0 is the hard-coded factory profile and cannot be overwritten.

After an initialization command, startup or reset of the camera, the ProfileID also indicates which profile was loaded on startup, reset or initialization.

**Note**



- The default profile is the profile that is loaded on power-up or an INITIALIZE command.
- A save or load operation delays the response of the camera until the operation is completed. At a time only one operation can be performed.

**Store** To store the current camera settings into a profile:

1. Write the desired ProfileID with the SaveProfile flag set.
2. Read back the register and check the ErrorCode field.

**Restore** To restore the settings from a previous stored profile:

1. Write the desired ProfileID with the RestoreProfile flag set.
2. Read back the register and check the ErrorCode field.

**Set default** To set the default profile to be loaded on startup, reset or initialization:

1. Write the desired ProfileID with the SetDefaultID flag set.
2. Read back the register and check the ErrorCode field.

#### Error codes

ErrorCode #	Description
0x00	No error
0x01	Profile data corrupted
0x02	Camera not idle during restore operation
0x03	Feature not available (feature not present)
0x04	Profile does not exist
0x05	ProfileID out of range
0x06	Restoring the default profile failed
0x07	Loading LUT data failed
0x08	Storing LUT data failed

*Table 147: User profiles: Error codes*

#### Reset of error codes

The ErrorCode field is set to zero on the next write access.

You may also reset the ErrorCode

- by writing to the USER\_PROFILE register with the SaveProfile, RestoreProfile and SetDefaultID flag not set.
- by writing 00000000h to the USER\_PROFILE register.

#### Stored settings

The following table shows the settings stored inside a profile:

Standard registers	Standard registers (Format_7)	Advanced registers
Cur_V_Frm_Rate Cur_V_Mode Cur_V_Format ISO_Channel ISO_Speed BRIGHTNESS AUTO_EXPOSURE (Target gray level) WHITE_BALANCE (+ auto on/off) HUE (+ hue on) SATURATION (+ saturation on) GAMMA (+ gamma on) SHUTTER (+ auto on/off) GAIN TRIGGER_MODE TRIGGER_POLARITY TRIGGER_DELAY ABS_GAIN	IMAGE_POSITION (AOI) IMAGE_SIZE (AOI) COLOR_CODING_ID BYTES_PER_PACKET	TIMEBASE EXTENDED_SHUTTER IO_INP_CTRL IO_OUTP_CTRL IO_INTENA_DELAY AUTOSHUTTER_CTRL AUTOSHUTTER_LO AUTOSHUTTER_HI AUTOGAIN_CTRL AUTOFNC_AOI (+ on/off) TRIGGER_DELAY MIRROR_IMAGE LUT_CTRL (LutNo; ON_OFF is not saved)

Table 148: User profile: stored settings

The user can specify which user profile will be loaded upon startup of the camera.

This frees the user software from having to restore camera settings, that differ from default, after every startup. This can be especially helpful if third-party software is used which may not give easy access to certain advanced features or may not provide efficient commands for quick writing of data blocks into the camera.

**Note**



- A profile save operation automatically disables capturing of images.
- A profile save or restore operation is an uninterruptable (atomic) operation. The write response (of the asynchronous write cycle) will be sent after completion of the operation.
- Restoring a profile will not overwrite other settings than listed above.
- If a restore operation fails or the specified profile does not exist, all registers will be overwritten with the hard-coded factory defaults (profile #0).
- Data written to this register will not be reflected in the standard memory channel registers.

## Pulse-width modulation (PWM)

**Note** See [Table 31: PWM configuration registers](#) on page 91.



## Global reset release shutter (Guppy PRO F-503 only)

Offset	Name	Field	Bit	Description
0xF10005C0	GLOBAL_RES_REL_SHUTTER	Presence_Inq	[0]	Indicates presence of this feature (read only)
		---	[1 to 5]	Reserved
		ON_OFF	[6]	Global reset release shutter on/off. If off, then electronic rolling shutter will be used.
		---	[7 to 31]	Reserved

Table 149: Advanced register: Global reset release shutter

## GPDATA\_BUFFER

GPDATA\_BUFFER is a general purpose register that regulates the exchange of data between camera and host for:

- writing look-up tables (LUTs) into the camera
- uploading/downloading of shading image (not used) and defect pixel correction data (only CMOS cameras)

GPDATA\_INFO Buffer size query

GPDATA\_BUFFER indicates the actual storage range

Register	Name	Field	Bit	Description
0xF1000FFC	GPDATA_INFO	BufferSize	[0 to 31]	Size of GPDATA_BUFFER (byte) Bit 0 to bit 254 is reserved for shading correction data (not used) Bit 255 is used for defect pixel correction (only CMOS cameras)
0xF1001000 ... 0xF10017FC	GPDATA_BUFFER			

Table 150: Advanced register: GPData buffer

**Note**

- Read the BufferSize before using.
- GPDATA\_BUFFER can be used by only one function at a time.

**Little endian vs. big endian byte order**

- Read/WriteBlock accesses to GPDATA\_BUFFER are recommended, to read or write more than 4 byte data. This increases the transfer speed compared to accessing every single quadlet.
- The big endian byte order of the 1394 bus is unlike the little endian byte order of common Intel PCs. Each quadlet of the local buffer, containing the LUT data for instance, has to be swapped bitwise from little endian byte order to big endian byte order before writing on the bus.

Bit depth	little endian⇒big endian	Description
8 bit	L0 L1 L2 L3⇒L3 L2 L1 L0	L: low byte
16 bit	L0 H0 L1 H1⇒H1 L1 H0 L0	H: high byte

*Table 151: Swapped first quadlet at address offset 0*

## Firmware update

Firmware updates can be carried out via FireWire cable without opening the camera.

### Note



For further information read the application note:  
How to update Guppy/Guppy PRO/Pike/Stingray firmware.

This application note and the firmware itself is only accessible for distributors. End customers have to contact technical support.

## Extended version number (FPGA/ $\mu$ C)

The new extended version number for microcontroller and FPGA firmware has the following format (4 parts separated by periods; each part consists of two digits):

Special.Major.Minor.Bugfix

or

xx.xx.xx.xx

Digit	Description
1st part: Special	Omitted if zero Indicates customer specific versions (OEM variants). Each customer has its own number.
2nd part: Major	Indicates big changes Old: represented the number before the dot
3rd part: Minor	Indicates small changes Old: represented the number after the dot
4th part: Bugfix	Indicates bugfixing only (no changes of a feature) or build number

*Table 152: New version number (microcontroller and FPGA)*



## Appendix

### Sensor position accuracy of Guppy PRO cameras

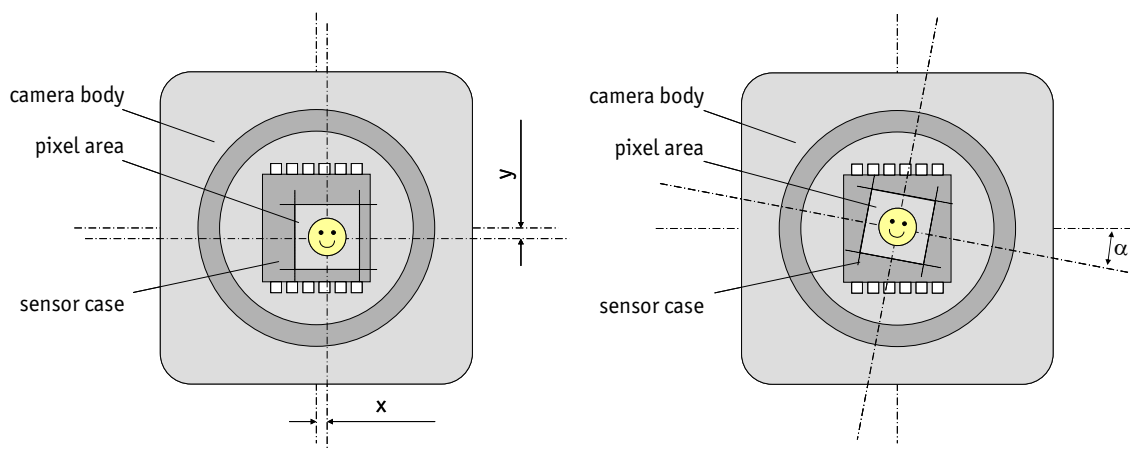

Figure 85: Sensor position accuracy

Criteria	Subject	Properties
Method of Positioning		Optical alignment of the photo sensitive sensor area into the camera front module (lens mount front flange)
Reference Points	Sensor	Center of the pixel area (photo sensitive cells)
	Camera	Center of the lens mount
Accuracy	x/y	+/- 150 $\mu\text{m}$ (sensor shift)
	z	+0/-100 $\mu\text{m}$ (optical back focal length)
	$\alpha$	+/-0.5° (center rotation as the deviation from the parallel to the camera bottom)

Table 153: Criteria of Allied Vision sensor position accuracy

#### Note

x/y tolerances between C-Mount hole and pixel area may be higher.



# Index

## Numerics

0xF1000010 (version info) .....	227
0xF1000040 (advanced feature inquiry) .....	229
0xF1000100 (camera status) .....	231
0xF1000200 (max. resolution) .....	232
0xF1000208 (time base) .....	232
0xF100020C (extended shutter).....	151, 233
0xF1000210 (test image) .....	235
0xF1000240 (LUT) .....	236
0xF1000298 (DPC_CTRL) .....	238
0xF1000300 (input control).....	85
0xF1000340 (Delayed IntEna).....	240
0xF1000360 (auto shutter control) .....	240
0xF1000370 (auto gain control) .....	242
0xF1000390 (autofunction AOI) .....	242
0xF10003A0 (color correction) .....	243
0xF1000400 (trigger delay) .....	244
0xF1000410 (mirror image).....	245
0xF1000510 (soft reset) .....	245
0xF1000550 (user profiles/memory channels/ user sets).....	251
0xF1000560 (Max. ISO size S400) .....	246
0xF1000564 (Max. ISO size S800) .....	246
0xF10005B0 (low-noise binning mode).....	249
0xF10005C0 (global reset release shutter) ...	254
0xF1000840 (debounce).....	148
0xF1000FFC (GPData buffer) .....	254
2 out of 4 H+V sub-sampling (color) drawing .....	126
2 out of 4 H+V sub-sampling (monochrome) drawing .....	126
2 out of 8 H+V sub-sampling (color) drawing .....	127
2 out of 8 H+V sub-sampling (monochrome) drawing .....	126
<b>A</b>	
Abs_Control (Field).....	100, 104, 106, 107, 109
Abs_Control_Inq (Field).....	86
access	
binning and sub-sampling .....	127
Access_Control_Register .....	214
AccessLutNo (Field) .....	236
accuracy	
sensor position .....	257
AddrOffset (Field) .....	236
Advanced feature inquiry .....	228
Advanced feature inquiry (advanced register) ...	229
Advanced features .....	224
activate .....	226
base address .....	214
inquiry.....	212
advanced register	
Advanced feature inquiry.....	229
Auto gain control.....	241, 242
Auto shutter control .....	240
Autofunction AOI.....	242
Camera status.....	231
Color correction .....	243
defect pixel correction.....	238
Delayed Integration Enable (IntEna) .....	240
Extended shutter.....	151, 233
Extended version.....	227
Format_7 mode mapping.....	248
global reset release shutter .....	254
GPData buffer .....	254
Input control .....	85
low-noise binning mode .....	249
LUT .....	236
Max. ISO packet .....	246
Max. resolution .....	232
Mirror .....	245
Mirror image .....	245
Output control .....	89
Soft reset .....	245
Test images .....	235
Time base .....	232
Trigger delay.....	244
User profiles.....	251
A_M_MODE (Field) .....	100, 105, 106, 107, 109
AOI.....	175
area of interest (AOI) .....	177
asynchronous broadcast.....	155
auto exposure	
limits.....	241
target gray level .....	108
target grey level .....	241

Auto Exposure (CSR register) .....	107	decrease .....	241
auto gain .....	105, 241	IIDC register .....	108
Auto gain control (advanced register) ..	241, 242	increase .....	108, 241
auto shutter .....	103, 104, 241	LUT .....	111
Auto shutter control (advanced register) ..	240	nonlinear .....	111
auto white balance .....	102	reference .....	104, 105
external trigger .....	103	setting .....	108
AUTO_EXPOSURE .....	107	sub-sampling .....	123
AUTOFNC_AOI .....	103, 242	variation .....	239
AUTOFNC_AOI positioning .....	103	Brightness (CSR register) .....	109
Autofunction AOI (advanced register) ..	242	Brightness Control .....	213
AUTOGAIN_CTRL .....	242	Brightness_inq .....	215
Auto_Inq .....	86	BRIGHTNESS_INQUIRY .....	215
AUTOSHUTTER_CTRL .....	240	buffer	
AUTOSHUTTER_HI .....	241	LUT .....	111
AUTOSHUTTER_LO .....	240	BuildDPData flag .....	115
		advanced register .....	238
<b>B</b>		bulk trigger .....	138, 141
bandwidth .....	158	bulk trigger (Trigger_Mode_15) .....	142
affect frame rate .....	192	Bus_Id .....	195
available .....	179	busy signal .....	88
frame rates .....	178		
RGB8 format .....	135	<b>C</b>	
save in RAW mode .....	131	Camera dimensions .....	70
Bayer demosaicing .....	130, 133	2 x 1394b copper .....	70
Bayer mosaic .....	130	camera interfaces .....	79
Bayer to RGB		Camera lenses .....	75
color interpretation .....	130	Camera status (advanced register) .....	231
binning .....	116	cameras	
access .....	127	block diagram .....	98
full .....	121	CAMERA_STATUS .....	231
horizontal .....	119	Camera_Status_Register .....	195
only Guppy PRO b/w .....	116	channel .....	94
vertical .....	117	color camera	
BitsPerValue .....	236	block diagram .....	99
black level .....	108	color coding .....	130
black value .....	108	color codings .....	130
blink codes .....	83	color correction .....	132, 133, 134
block diagram		Allied Vision cameras .....	133
color camera .....	99	formula .....	133
monochrome camera .....	98	why? .....	132
block diagrams		Color correction (advanced register) .....	243
cameras .....	98	color information .....	130
BRIGHTNESS .....	108, 109, 220	Color_Coding .....	130
Brightness		COLOR_CODING_INQ .....	130
inquiry register .....	213	common GND	
brightness		inputs .....	80
auto shutter .....	104	common vcc	
average .....	105	outputs .....	80

conformity.....	37
continuous	
using Trigger_Mode_15 .....	144
controlling	
image capture.....	136
CSR.....	195
shutter .....	104
CSR register	
Auto Exposure .....	107
Brightness .....	109
GAIN .....	106
<b>D</b>	
data block packet format.....	93
description .....	94
data exchange buffer	
LUT .....	111
data packets.....	93
data path.....	98
Data payload size .....	47
data payload size .....	192
data_length .....	94
DCAM .....	35, 158, 195
debounce time	
for input ports .....	148
debounce time for trigger.....	147
defect pixel correction	
advanced register .....	237
build and store.....	114
building defect pixel data .....	114
calculated mean value .....	238
max. 2000 defect pixels .....	238
mechanisms .....	113
defect pixel correction (advanced register) ..	238
defect pixel correction (DPC).....	237
Delayed Integration Enable (IntEna) (advanced register) .....	240
DelayTime .....	239
Digital Camera Specification (DCAM) .....	195
digital video information .....	94
digitizer .....	111
Document history .....	23
DPC (defect pixel correction).....	237
DPC_CTRL.....	238
DPC_INFO.....	239
DPC_MEM .....	238
DPDataSize	
defect pixel data size (max. 2000) .....	238

**E**

edge mode (Trigger_Mode_0).....	87, 138
effective min. exp. time.....	150
electronic rolling shutter (ERS) .....	137
EnableMemWR (Field) .....	236
End of exposure.....	153
error code	
user profiles .....	252
error codes	
LED .....	83
error states.....	83
ERS (=electronic rolling shutter).....	137
ExpOffset .....	232
Exposure time	
(Field).....	151
exposure time .....	149
81 Ch register .....	151
example.....	150
extended shutter.....	233
formula .....	149
longest .....	151
long-term integration.....	151
minimum .....	150
ExpTime (Field).....	151
EXTD_SHUTTER .....	233
extended shutter .....	151
FireDemo.....	234
FireView .....	234
inactive.....	151, 234
register.....	233
trigger mode .....	138
Extended shutter (advanced register) ..	151, 233
Extended version (advanced register) .....	227
EXTENDED_SHUTTER .....	149, 151
External GND .....	80
external trigger.....	84

**F**

FireDemo	
extended shutter.....	234
FirePackage	
OHCI API software .....	35
FireView	
extended shutter.....	234
FireWire	
Connection capabilities.....	44
Definition.....	42
Serial bus .....	43

FireWire 400 .....	45	GRR (global reset release shutter)	
FireWire 800 .....	45	description .....	137
firmware update .....	256, 257	Guppy PRO types .....	36
flash .....	137	<b>H</b>	
Focal length .....	75	hardware trigger .....	87, 146
Guppy PRO F-031 .....	76	heat dissipation .....	39
Guppy PRO F-032 .....	76	horizontal binning .....	119
Guppy PRO F-033/046/146.....	77	horizontal sub-sampling (color)	
Guppy PRO F-503 .....	78	drawing .....	124
Format_7 mode mapping (advanced register) ...		horizontal sub-sampling (monochrome)	
<b>248</b>		drawing .....	124
Format_7 modes		hue .....	132
mapping .....	129	offset .....	132
formula		<b>I</b>	
color correction.....	133	ID	
frame rates .....	158	color coding .....	130
bandwidth.....	178	IEEE 1394 .....	35
bus speed .....	158	IEEE 1394 standards .....	42
Format_7 .....	182	IEEE 1394 Trade Association .....	195
maximum.....	158	IEEE 1394b connector .....	79
tables .....	178	IEEE1394a data transmission.....	43
video mode 0.....	181	IEEE1394b	
video mode 2.....	181	bandwidths .....	47
Frame valid .....	88	IEEE1394b data transmission .....	44
free-run .....	155	IIDC .....	35, 158, 195
full binning.....	121	data structure.....	96, 97
Fval .....	88	isochronous data block packet format ...	93
Fval signal.....	88	pixel data .....	93
<b>G</b>		trigger delay .....	86
gain		video data format.....	94
auto .....	105	YUV 4:1:1.....	94, 95, 96
auto exposure CSR.....	105	YUV 4:2:2.....	94, 95, 96
AUTOFNC_AOI .....	103	IIDC V1.31.....	136
manual .....	108	IIDC V1.31 camera control standards .....	45
manual gain range .....	108	image capture	
ranges .....	108	controlling.....	136
GAIN (CSR register).....	106	IMAGE_POSITION .....	175
GAIN (name) .....	106	IMAGE_SIZE .....	175
GAIN (register).....	101	input	
gain CSR .....	108	block diagram .....	84
gamma function .....	110	signals .....	84
gamma LUT.....	110	Input control (advanced register) .....	85
global reset release shutter (GRR)		input mode .....	85
advanced register .....	254	input/output pin control .....	239
description .....	137	InputMode (Field) .....	85
global shutter .....	136	inputs	
GPData buffer (advanced register) .....	254	common GND .....	80
GPDATA_BUFFER .....	111		

general .....	84	example.....	110
in detail .....	84	gamma .....	110
triggers .....	84	general .....	110
inquiry		loading into camera .....	111, 112
trigger source 0 .....	216	volatile .....	111
Inquiry register		LUT (advanced register) .....	236
basic function .....	212	LUT_CTRL .....	236
Integration Enable signal .....	88	LUT_INFO .....	236
IntEna .....	80, 91	LUT_MEM_CTRL .....	236
IntEna signal.....	88, 239	LutNo .....	235
IntEna_Delay .....	91	LutNo (Field) .....	236
IntEna_Out .....	239	<b>M</b>	
internal trigger .....	138, 141	Manual_Inq .....	86
interpolation		Max. ISO packet (advanced register) .....	246
Bayer demosaicing.....	130, 131	Max. resolution (advanced register) .....	232
Bayer to RGB .....	130	Maximum resolution (Register).....	231
color .....	130	MaxLutSize (Field) .....	236
IO_INP_CTRL1 .....	85	MAX_RESOLUTION .....	232
IO_OUTP_CTRL1 .....	89	MaxResolution (Field) .....	229
IO_OUTP_CTRL2 .....	89	MaxSize (Field) .....	239
IO_OUTP_CTRL3 .....	89	Max_Value .....	86
isochronous blocks .....	94	MaxValue .....	242
isochronous channel number .....	94	Mean	
isochronous data block packet format.....	93	defect pixel mean value .....	238
isochronous data packets .....	93	mechanical shutter.....	141
Isochronous Resource Manager (IRM).....	247	memory channels (user profiles,user sets) ...	250
ISO_Enable .....	155	Min. exp. time + offset .....	150
IsoEnable		minimum exposure time .....	150
white balance .....	102	Min_Value .....	86
ISO_Enable mode.....	155	MinValue.....	242
multi-shot .....	155	Mirror (advanced register).....	245
one-shot .....	151	Mirror image (advanced register).....	245
<b>J</b>		monochrome camera	
jitter .....	154, 156	block diagram .....	98
at exposure start .....	156	MSB aligned .....	94
<b>L</b>		multi-shot.....	155
LCD shutter .....	141	external trigger .....	155
LED		using Trigger_Mode_15.....	144
error codes.....	83	<b>N</b>	
indication .....	82	Node_Id .....	195
status .....	82	NumOfLuts .....	235
level mode (Trigger_Mode_1) .....	138	NumOfLuts (Field) .....	236
look-up table (LUT).....	110, 235	<b>O</b>	
user-defined .....	110	OFFSET	
low-noise binning mode (advanced register) 249		auto white balance .....	101
LUT.....	235	offset.....	149
data exchange buffer .....	111		

800h .....	108	PinState (Field) .....	85
CCD.....	108	PinState flag.....	89
configuration ROM .....	199	pixel data .....	93
factors.....	199	plus integral controller .....	105
hue .....	132	Polarity (Field) .....	85, 89
initialize register .....	201	Power	
inquiry register video format .....	201	IEEE 1394b .....	79
inquiry register video mode.....	202	power	
saturation .....	132	GND.....	80
setting brightness .....	108	presence	
setting gain .....	108	trigger source 0.....	216
OHCI API		Presence_Inq .....	85
FirePackage .....	35	Presence_Inq (Field) .....	86, 100
One_Push (Field).....	100, 104, 106, 107, 109	programmable mode (Trigger_Mode_15)....	138
one-push white balance .....	101, 102	pulse-width modulation	
One_Push_Inq.....	86	signal .....	88
one-shot.....	151	PulseWidthMod signal .....	88
Trigger_Mode_15.....	138, 141		
using Trigger_Mode_15 .....	144		
values.....	153	<b>R</b>	
one-shot bit .....	151	read value	
one-shot mode .....	151	trigger input .....	216
ON_OFF .....	86	Readout_Inq .....	86
ON_OFF (Field) .....	100	RGB to YUV	
optocoupler .....	84	formula .....	135
output		RGB8 format .....	135
block diagram .....	88	row time	
signals .....	88	Guppy PRO F-503 .....	149
Output control (advanced register) .....	89	<b>S</b>	
output impulse diagram		safety .....	2, 8
WaitingForTrigger.....	90	heat dissipation.....	39
output mode .....	89	lens mounts .....	39
ID .....	90	saturation.....	132
Output mode (Field) .....	89	offset .....	132
output pin control.....	90	Sensor position accuracy .....	257
outputs .....	88	sequence	
common vcc .....	80	loading a LUT .....	112
general .....	84	one-push white balance.....	102
registers .....	89	OneShot .....	151
set by software .....	91	SHUTTER .....	104, 105
OutVCC .....	80	Shutter CSR.....	104
<b>P</b>		shutter time	
Packed 12-Bit Mode .....	130	formula .....	149
Packed 12-Bit MONO .....	130	SHUTTER_MODES .....	136
Packed 12-Bit RAW.....	130	signal-to-noise ratio (SNR) .....	117
packet format.....	93	vertical binning .....	119
PI controller .....	105	signal-to-noise separation .....	117
pin control.....	239	SmartView .....	35
		SNR .....	117

Soft reset (advanced register).....	245	time response .....	152
software trigger .....	147	TIMEBASE.....	225, 232
Software_Trigger (CSR) .....	218	TimeBase (Field) .....	229
Spectral transmission		TPA-	
IR cut filter .....	75	IEEE 1394b .....	79
Standard housing .....	70	TPA(R)	
status LED.....	82	IEEE 1394b .....	79
stored settings		TPA+.....	79
user profile, user set .....	253	TPB-	
Styles.....	33	IEEE 1394b .....	79
sub-sampling		TPB(R)	
access .....	127	IEEE 1394b .....	79
brightness .....	123	TPB+.....	79
definition .....	123	IEEE 1394b .....	79
monochrome and color .....	123	transaction code (tCode).....	94
sy (sync bit).....	93, 94	trigger	
Symbols .....	33	bulk .....	138, 141
sync bit (sy).....	93, 94	control image capture .....	136
synchronization value (sync bit) .....	94	delay.....	86, 91
System components .....	75	edge .....	87
<b>T</b>		external .....	136
tag field.....	94	hardware .....	87, 146
target grey level		impulse .....	152
corresponds to Auto_exposure .....	220	IntEna .....	91
Target grey level (auto exposure) .....	108, 241	internal.....	138, 141
Target grey level (SmartView)		latency time .....	156
corresponds to auto exposure .....	104	microcontroller .....	153
tCode.....	94	one-shot .....	151
test image .....	193	signal .....	84
b/w cameras.....	193	software .....	155
Bayer-coded .....	194	synchronize .....	156
color .....	194	trigger delay.....	144
color cameras .....	194	advanced CSR .....	87, 146
configuration register.....	235	advanced register .....	87, 146
grey bar .....	193	off .....	87
save .....	234	on.....	87
Test images (advanced register).....	235	Trigger delay (advanced register) .....	244
TEST_IMAGE .....	235	Trigger Delay CSR.....	87
tg .....	94	trigger delay CSR.....	146
threshold		Trigger delay inquiry register .....	145
defect pixel correction.....	115, 238	trigger delay inquiry register .....	86
time base .....	150	trigger function .....	143
exposure time.....	149	trigger input	
setting .....	234	read raw data .....	216
trigger delay .....	86, 144	trigger modes.....	138
Time base (advanced register) .....	232	trigger source 0	
time base (Register).....	232	inquiry.....	216
time base ID.....	233	TRIGGER_DELAY .....	87, 146
		TRIGGER_DELAY_INQUIRY .....	86, 145



TRIGGER_MODE .....	143	video format	
Trigger_Mode .....	143	available bandwidth.....	178
Trigger_Mode_0 (edge mode) .....	87, 138	frame rate.....	178
Trigger_Mode_0 Guppy PRO F-503		video Format_7	
electronic rolling shutter .....	140	AOI .....	175
global reset release shutter .....	141	video formats.....	158
Trigger_Mode_1 (level mode) .....	138	Guppy F-503.....	173
Trigger_Mode_15 (bulk trigger) .....	138, 142	video information .....	94
Trigger_Mode_15 (programmable mode)....	138	video mode	
Trigger_Polarity .....	143	CUR-V-MODE.....	218
triggers .....	84	Format_7 .....	222
input .....	84	inquiry register .....	202
Trigger_Source .....	143	sample C code .....	197
Trigger_Source0_Inq .....	216	video mode 0 .....	181
Trigger_Value .....	143	video mode 2 .....	181
Tripod adapter .....	71	VP	
Tripod dimensions.....	71	IEEE 1394b .....	79
types		VP (Power, VCC)	
Guppy PRO cameras.....	36	IEEE 1394b .....	79
<b>U</b>		<b>W</b>	
U/B_Value (Field) .....	100	WaitingForTrigger	
U/V slider range .....	101	ID 0x0A.....	90
UNIT_POSITION_INQ .....	175	output impulse diagram.....	90
UNIT_SIZE_INQ.....	175	WaitingForTrigger signal.....	88
user profile, user set		white balance	
stored settings .....	253	auto .....	102
user profiles .....	250	auto shutter .....	104
error code .....	252	AUTOFNC_AOI .....	103
User profiles (advanced register) .....	251	conditions .....	102, 103
user sets.....	250	general .....	99
<b>V</b>		one-push .....	101, 102
V/R_Value (Field) .....	100	register 80Ch .....	100
VCC		six frames .....	101
IEEE 1394b .....	79	WHITE_BALANCE .....	100, 102
Vendor Unique Color_Coding .....	130		
Vendor unique Features .....	212		
vertical binning .....	117		
SNR.....	119		
vertical sub-sampling (color)			
drawing .....	125		
vertical sub-sampling (monochrome)			
drawing .....	125		
VG (GND)			
IEEE 1394b .....	79		
video data format			
IIDC V1.31 .....	94		
Video data payload.....	94		